



SIMPSON
Strong-Tie
®

In the Specs – On the Job – At Your Service™

Anchoring and Fastening Systems

For Concrete and Masonry

2012-2013
C-SAS-2012

Adhesives
Mechanical Anchors
Gas & Powder Actuated
Carbide

(800) 999-5099
www.strongtie.com





**In The Specs
On The Job**

At Your Service™

Under One Brand—Unified in Our Mission and Committed to the Customer

For more than 55 years, Simpson Strong-Tie has continuously worked toward helping our customers succeed by providing innovative products, full-service engineering and field support, product testing and training, and on-time product delivery. Simpson Strong-Tie offers a full array of products for residential, commercial and industrial construction. As we continue to move into other commercial and infrastructure markets, we will introduce new products designed to protect, repair and strengthen concrete, wood and steel structures. These new product lines, like all of our others, will feature the Simpson Strong-Tie brand and logo – and the trusted levels of service and quality you've come to expect.

To learn more, visit:

www.strongtie.com



NEW PRODUCTS

GCN-MEP

The new GCN-MEP gas-actuated concrete nailer is the ideal solution for attaching light-duty fixtures to concrete, CMU and metal deck for mechanical, electrical and plumbing (MEP) attachments. Since the tool does not require electrical cords or pneumatic hoses, the gas-actuated GCN-MEP is extremely portable, which helps to increase productivity.

For more information about this product, go to page 179.



Strong-Bolt® 2

This innovative, new wedge anchor features a re-designed, tri-segmented clip made of special, high-strength alloy that enables it to outperform many other cracked-concrete wedge anchors, including the original Strong-Bolt®. Strong-Bolt 2 has also received classification as a Category 1 anchor, which is the highest reliability rating as outlined by the ICC-ES AC193 acceptance criteria. It has been tested and code listed under the 2009 IBC requirements for installation in the most adverse conditions, including performance in cracked concrete under static and seismic loading.

For more information about this product, go to page 96.



ICC-ES ESR-3037

Titen HD Threaded Rod Hanger

Two new designs of the Titen HD® rod hanger feature a 3/8" dia. shank that specifically qualifies these models for code listing by ICC-ES for cracked and uncracked concrete applications under the 2009 IBC. These high-strength screw anchors are designed to suspend threaded rod from concrete slabs and beams in order to hang pipes, cable trays and HVAC equipment.

For more information about this product, go to page 123.



ICC-ES ESR-2713

New Feature-Packed Powder-Actuated Tools for a Range of Applications

Our two new premium tool designs offer reduced recoil and noise and are available in single-pin and magazine configurations for fully automatic fastening. The PTP-27S single-pin and PTP-27SMAGR magazine versions are designed for high-volume applications using shorter pins up to 1 3/4" long (1 1/4" with magazine) such as drywall, acoustic ceiling and HVAC. The longer-barreled PTP-27L and PTP-27LMAGR provide versatility and ease of use for these applications and can also handle pins up to 2 1/2" long (3" with magazine) for applications such as fastening mudsills to concrete.

For more information about these products, go to pages 192–193.



NEW PRODUCTS



New Epoxy Dispensing Tools Offer Added Durability

The EDT22S is a new manual epoxy dispensing tool for 22 oz. adhesive cartridges. The EDT22S features a steel carriage and is engineered for high-volume, continuous use. A new manual dispensing tool for SET-XP 10 oz. cartridges, the CDT10S is also available. Both the CDT10S and EDT22S feature double-gripping plates that provide reliable dispensing thrust and help extend tool life.

For more information about these products, go to page 72.



New Steel Acrylic Dispensing Tools Deliver Consistent Performance

The new ADT30S offers reliable manual dispensing of 30 oz. acrylic cartridges. The tool features a steel carriage for ultimate durability and is engineered for high-volume use. For smaller jobs, Simpson Strong-Tie has also introduced the ADT813S for dispensing 12.5 oz acrylic cartridges. Both tools feature double-gripping plates that provide reliable dispensing thrust and help extend tool life.

For more information about these products, go to page 73.



Versatile Pneumatic Dispensing Tools for Larger Projects

Designed to increase production on large anchoring or doweling jobs, new pneumatic tools for dispensing 22 oz. and 56 oz. epoxy cartridges feature an adaptive suitcase handle for the ultimate in tool configuration and dispensing convenience. These lightweight tools also feature a power piston return. The EDTA22P and EDTA56P both come with a rugged carrying case.



Simpson Strong-Tie has also introduced the ADTA30P, a new pneumatic dispensing tool for 30 oz. acrylic cartridges. The ADTA feature the same rugged, yet lightweight construction of the EDTA tools. The suitcase option enables easier and time-saving ground-level doweling

For more information about these products, go to pages 72–73.



Spiral-Knurl Pins for Our Gas-Actuated Concrete Nailers

GDPSK gas-actuated-fastening pins are designed for attaching plywood and OSB to cold-formed steel studs. The spiral knurl provides a positive lock and resists back out. Installed with the GCN150 concrete nailer or GCN-MEPMAG, the GDPSK-138 gas pin provides faster installation and set up times, which contributes to lower labor costs.

For more information about these products, go to page 186.



Table of Contents

Adhesives

AT Acrylic Adhesive	53–66
Acrylic Usage Estimation Guides	67–69
NEW Adhesive Accessories	72–77
Adhesive Anchoring Installation Instructions	70–71
Adhesive Troubleshooting Guide	78
Crack-Pac® Injection Adhesive	86–89
Crack-Pac® Flex H ₂ O™ Injection Adhesive	90–93
Crack Repair Accessories	94
EDOT™ Adhesive	47
Epoxy Crack Injection Guide	88–89
Epoxy Usage Estimation Guides	48–51
ETI-SLV, -LV and -GV Injection Adhesives	85, 88–89
ET-HP™ Adhesive (formerly ET)	37–46
Retrofit Bolt	77
SET Adhesive	22–36
SET-XP® Adhesive	16–21
VGC Vinylester Glass Capsule	79–83

Mechanical Anchors

Blue Banger Hanger® Threaded Insert	157
Crimp Anchor	168
Drop-In Anchor	150
Easy-Set Expansion Anchor	161
Expansion Screw Anchor	172
Heli-Tie™ Helical Wall Tie	166
Hollow Wall Anchor	174
Lag Screw Expansion Shield	172
Machine Screw Anchor	173
Nailon Pin Drive Anchor	171
Plastic Screw Anchor	175
Sleeve-All® Anchor	146
Split Drive Anchor	170
Spring Wing Toggle Bolt	177
Strong-Bolt® Wedge Anchor	106
NEW Strong-Bolt® 2 Wedge Anchor	96
Sure Wall Drywall Anchor/Toggle	176
Tie-Wire Wedge-All® Anchor	133
Titen® Screw	162
Titen® Stainless-Steel Screw	164
Titen HD® Anchor	110
Titen HD® Mini Anchor	122
Titen HD® Rod Coupler	127
NEW Titen HD® Rod Hanger	123
Torq-Cut™ Anchor	129
Wedge-All® Anchor	133

Gas-Actuated Fastening

NEW GCN-MEP Gas-Actuated Concrete Nailer	179
GCN150 Gas-Actuated Concrete Nailer	182
NEW Gas-Actuated Fasteners and Accessories	183–186

Powder-Actuated Fastening

Application Matrix - Tools/Trades	188–189
NEW Extension Pole Tools/Accessories	187
Fastener Tension and Shear Loads	208–214
Powder-Actuated Tools	
NEW PTP-27L	192
NEW PTP-27LMAGR	192
NEW PTP-27S	193
NEW PTP-27SMAGR	193
PT-27	195
PT-22	196
PT-22GS	197
PT-22H	198
PT-22P	199
NEW Powder-Actuated Fasteners	201–214
Powder Loads	200
Repair Kits	207
Safety Principles	187
Tool/Load/Fastener Matrix	190–191

Drill Bits and Chisels

'A' Taper Drill Bits	219
Bushing Tools	222
Core Bits	222
Demolition Chisels and Bits	221
Drill Bit Tool Selection Guide	216
Ground Rod Drivers	220
Plate Cutters	220
Rebar Cutters	220
Scalers	220
SDS-Max Drill Bits	218
SDS-Plus Drill Bits	217–218
Shank Adaptors	220
Spline Shank Drill Bits	218–219
Straight Shank Drill Bits	219
Warranty Claims	223

Other

Allowable Stress Design Method	226
Alphabetical Index of Products	17
Anchor Selection Guide	8
Corrosion Information	11
Example Design Calculations	231–237
General Installations for the Installer	13
General Instruction for the Designer	14
Glossary of Common Terms	238
Limited Warranty	10
Supplemental Topics for Anchors	224
Table Icons	13
Technical Support	11
Treatment of Design Methods	229
Strength Design Method	226

























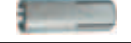



Special Section

Connectors for Cold-Formed Curtain-Wall Construction	240–251
---	---------

Alphabetical Index of Products

AD – Drill Bit Shank Adaptor	220	GFC – Gas Fuel Cell	185	PHK – 6MM Headed Pin	205
ADT – Acrylic Dispensing Tools	73	GMR – Magnetic Ring	185	PHN – 8MM Headed Pin	204
NEW ADTA – Pneumatic Dispensing Tools	73	GRH, GTH, GTS, GW – Gas Pins	180	PHNT – 8MM Headed Tophat Fastener	205
AMN – Acrylic Mixing Nozzle	74	GWL – Lathing Washer	185	PHNW – 8MM Headed Pin with 1" Washer	205
ARC – Adhesive Retaining Caps	74	HELI – Helical Wall Tie	166	PHSNA – Collated Fasteners – Metric	206
AST – Adhesive Shear Tube	77	HWA – Hollow Wall Anchor	174	PHV3 – 3/8" Headed Pin	203
AT – Acrylic Adhesive	53	LSES – Lag Screw Expansion Shield	172	PINW – 100 through 300 – .300" Headed Pin with 1 7/16" Washer	202
ATS & ATSP – Acrylic Screens	75–76	MC – Rebar Cutter Shank – Straight	220	PINWP – 100 through 300 – .300" Headed Pin with 1 7/16" Plastic Washer	203
BBMD – Blue Banger Hanger®	157	MCP – Plate Cutter Head	220	PKP – Concrete Forming Pin	206
BBRD – Blue Banger Hanger®	157	MCR – Rebar Cutter Head	220	PSATG – Plastic Screw Anchor	175
BBWF – Blue Banger Hanger®	157	MCS – Rebar Cutter Shank – Spline	220	PSLV3 – 3/8" Threaded Stud	204
CBMX – One Piece Core Bit – SDS-MAX Shank	222	MCSDM – Rebar Cutter Shank – SDS-MAX	220	PSLV4 – 1/4" Threaded Stud	204
CBSP – One Piece Core Bit – Spline Shank	222	MCSDP – Rebar Cutter Shank – SDS-PLUS	220	PSP – Piloted Setting Punch	172
CD – Crimp Anchor	168	MDA – 'A' Taper Shank Drill Bits	219	PT-22 – .22 Cal. Powder-Actuated Tool	196
CDBE – One Piece Core Bit – Ejector Key	222	MDB – Straight Shank Drill Bits	165, 219	PT-22GS – .22 Cal. Grip Shot™ Powder-Actuated Tool	197
NEW CDT10S – Premium Adhesive Dispensing Tool	72	MDMX – SDS-MAX & SDS-MAX Quad Head Bits	218	PT-22H – Hammer Activated Powder Tool	198
CHH – Hex Shank Chisels & Demolition Bits	221	MDPL – SDS-PLUS Shank Bits	217–218	PT-22P – Powder-Actuated Tool	199
CHMX – SDS-MAX Chisels & Demolition Bits	221	MDSP – Spline Shank Drill Bits	218–219	PT-27 – .27 Cal. Powder-Actuated Tool	195
CHPL – SDS-PLUS Chisels & Demolition Bits	221	MSD – Mushroom Head Split Drive	170	PT-27HD – Heavy-Duty Powder-Actuated Tool	194
CHSP – Spline Shank Chisels & Demolition Bits	221	N – Nailon (nylon)	171	NEW PTP-27L – .27 Cal. Auto Powder-Actuated Tool	192
CIP – Crack Injection Paste Over	94	P22 – .22 Cal. Powder Load – Single, Crimped	200	NEW PTP-27LMAGR – .27 Cal. Auto Powder- Actuated Tool w/ Magazine	192
CIP-F – Crack Injection Paste Over	94	P22LRSC – .22 Cal. Powder Load – Single, Straight Wall	200	NEW PTP-27S – .27 Cal. Auto Powder-Actuated Tool	193
CPFH09 – Crack-Pac® Flex-H ₂ O™ Crack Sealer	90	P25SL – .25 Cal. Powder Load – Strip	200	NEW PTP-27SMAGR – .27 Cal. Auto Powder- Actuated Tool w/ Rotating Magazine	193
CSD – Countersunk Split Drive	170	P27LVL – .27 Cal. Powder Load – Single, Long	200	NEW PTRH – Threaded Rod Hanger	206
CTRB – One Piece Core Bit – Center Pilot Bit	222	P27SL – .27 Cal. Powder Load – Strip	200	RFB – Retrofit Bolt	77
DIA – Drop-In™ Anchor	150	PBXDP – BX Cable Strap	203	SET – Epoxy Adhesive	22
DIAS – Drop-In Anchor Setting Tool	151	PCC – Conduit Clip	203	SET-XP™ – Epoxy Adhesive	16
DMSA – Double Machine Screw Anchor	173	PCLDP – Ceiling Clip	203	SL – Sleeve-All® Anchor	146
DSD – Duplex Head Split Drive	170	PDP – .300" Headed Pin	201	SMSA – Single Machine Screw Anchor	173
EDOT™ – General-Purpose Anchoring Adhesive	47	NEW PDPA – .300" Headed Fastener with .157" Shank Diameter	201	STB – Strong-Bolt® Wedge Anchor	106
EDT – Epoxy Dispensing Tools	72	PDPH – .300" Headed Fasteners with .177" Shank Diameter	201	NEW STB2 – Strong-Bolt® 2 Wedge Anchor	96
NEW EDTA – Pneumatic Dispensing Tools	72	PDPHMG – .300" Headed Fasteners with .177" Shank Diameter – Mechanically Galvanized	202	SWN – Sure Wall Anchor (Nylon)	176
EIF – Injection Fitting	94	PDPHWL – .300" Headed Fasteners with 1" Metal Washers with .177" Shank Diameter	202	SWTB – Spring Wing Toggle Bolt	177
EIP – Injection Port	94	PDPMG – .300" Headed Fasteners – Mechanically Galvanized	202	SWTH – Toggle Only	177
EMN – Epoxy Mixing Nozzle	74	PDPSS – Type 316 Stainless-Steel .300" Headed Fasteners	201	SWZ – Sure Wall Anchor (Zinc)	176
EMNO – Opti-Mix® Mixing Nozzle	94	PDPW – .300" Headed Pin with 3/4" Washer	202	SWZT – Sure Wall Toggle	176
ESA – Expansion Screw Anchor	172	PDPWL – .300" Headed Pin with 1" Washer	202	TCA – Torq-Cut™ Anchor	129
ET-HP™ (formerly ET) – Epoxy Adhesive	37	PDPWLMG – .300" Headed Fasteners with 1" Metal Washers – Mechanically Galvanized	202	THD – Titen HD® Anchor	110
ETB – Hole Cleaning Brush	77	PDPWLSS – 316 Stainless-Steel .300" Headed Fastener with 1" Washer	202	THD MINI – Small Titen HD® Anchor	122
ETI – Crack Injection Epoxy	85	PDPT – .300" Headed Tophat Pin	203	THD RC – Titen HD® Rod Coupler	127
ETIPAC – Crack-Pac® Injection Epoxy	86	PECLDP – Ceiling Clip	203	THD RH – Titen HD® Rod Hanger	123
ETR – Epoxy Paste-Over	94	PET – Extension Pole Tools	187	TTN – Titen® Screw	162
ETS & ETSP – Epoxy Screens	75–76	PHBC – Highway Basket Clip	203	TTNSS – Titen® Stainless-Steel Screw	164
EZAC – Pin Drive Anchor	161	PHD – Hammer Drive Pin	207	TTNT – Titen® Screw Installation Tool	165
E-Z-CLICK – Injection System	94	PHT – Hammer Drive	207	TWD – Tie-Wire Anchor	133
NEW GCN – Gas-Actuated Concrete Nailers	179, 182			VGC – Vinylester Glass Capsule	79
GAC, GBR, GCC, GCL, GCT – Gas Pins	180			WA – Wedge-All® Anchor	133
GDP – Gas Pins	183			ZN – Nailon (zinc)	171
GDPS – Gas Pins	185				
NEW GDPSK – Gas Pins	186				

Anchor Selection Guide

	BASE MATERIAL							ALLOWABLE TENSION LOAD ^{1,2}			CODE RECOGNITION ¹
	Page No.	Concrete	Lightweight Concrete over Metal Deck	Grout-Filled Concrete Block	Hollow Concrete Block	Solid Brick	Hollow Brick	500 lbs (2.2 kN) or less	500 lbs (2.2 kN) to 2,000 lbs (8.9 kN)	2,000 lbs (8.9 kN) or greater	
SET-XP™ 	16	● (Including Cracked)						●	●	●	ICC-ES; Florida; NSF 61; City of L.A.; Various DOT
SET and ET-HP™ (formerly ET) 	22, 37	●	●	●	●	●	●	●	●	●	ICC-ES; City of L.A.; Florida; Various DOT; NSF 61 (SET)
EDOT 	47	●						●	●	●	Various DOT
Acrylic-Tie® 	53	●	●	●	●	●	●	●	●	●	ICC-ES; City of L.A.; Florida; NSF 61; Various DOT
VGC (Hammer Capsule) 	79	●						●	●	●	Various DOT
Strong-Bolt®2 	96	● (Including Cracked)	● (Including Cracked)	●				●	●	●	ICC-ES; City of L.A.; Underwriters Laboratories; Factory Mutual ¹
Strong-Bolt® 	106	● (Including Cracked)						●	●	●	ICC-ES; City of L.A.; Florida
Titen HD® 	110	● (Including Cracked)	● (Including Cracked)	●	●	●	●	●	●	●	ICC-ES; City of L.A.; Florida; Factory Mutual
Titen HD® Mini 	122	●	●	●	●	●	●	●	●		
Titen HD® Rod Hanger 	123	●	●	●	●	●	●	●	●		Factory Mutual; ICC-ES pending (THD50234RH)
Titen HD® Rod Coupler 	127	●						●	●	●	
Torq-Cut™ Anchor 	129	● (Including Cracked)						●	●	●	ICC-ES pending
Wedge-All® 	133	●	●	●				●	●	●	ICC-ES; City of L.A.; Florida; Underwriters Laboratories; Factory Mutual
Tie Wire Wedge-All® 	133	●	●	●				●			
Sleeve-All® 	146	●		●			●	●			Underwriters Laboratories; Factory Mutual
Drop-In 	150	●	●					●	●	●	City of L.A.; Underwriters Laboratories; Factory Mutual
Blue Banger Hanger® 	157	●	●					●	●	●	Underwriters Laboratories; Factory Mutual
Easy-Set Expansion Anchor 	161	●		●				●	●	●	
Titen® Concrete and Masonry Screw 	162	●		●	●	●	●	●			Florida
Heli-Tie™ Helical Wall Tie 	166	●		●	●	●	●	●			
Crimp Anchor 	168	●	●	●				●	●		Factory Mutual
Split Drive Anchor 	170	●		●				●			
Nailon™ Zinc or Nylon 	171	●		●	●	●	●	●			
Lag Screw Expansion Shield 	172	●		●	●	●	●	●			
Expansion Screw Anchor 	172	●		●				●			
Machine Screw Anchor 	173	●		●				●	●		
Hollow Wall Anchors 	174	Plywood and Gypsum Drywall			●		●				
Plastic Wall Anchor 	175	●		●	●	●	●				
Sure Wall and Sure Wall Toggle 	176	Plywood and Gypsum Drywall									
Spring Wing Toggle Bolt 	177				●		●				
Gas Pins	183	●	●	●	●			●	●		ICC-ES, Florida
Powder-Actuated Fasteners	201	●	●	●	●			●	●		ICC-ES; City of L.A.; Florida; Factory Mutual

1. Load values and code listings may not be available for all base materials cited in the table. To verify code listed applications refer to the code report at www.strongtie.com or contact Simpson Strong-Tie Company Inc. at 1 (800) 999-5099 (U.S. and Canada).

2. For Strength Design (SD), reference SD performance data in this catalog.

Simpson Strong-Tie Company Inc.

The Simpson Strong-Tie Company Inc. was founded in Oakland, California and has been manufacturing wood-to-wood and wood-to-concrete connectors since 1956. Since then, Simpson Strong-Tie has grown to be the world's largest manufacturer of construction connectors. In recent years the company's growth has included expanding its product offering to include pre-manufactured shearwalls, anchor systems for concrete and masonry and collated fastening systems.

The Simpson Strong-Tie Company Inc. program includes:

- Quality products value-engineered for the lowest installed cost at the highest rated performance levels.
- Most thoroughly tested and evaluated products in the industry.
- Strategically-located manufacturing and/or warehouse facilities.
- Field Engineering support.
- National code agency listings.
- National factory sales team.
- In-house R&D, and tool and die professionals.
- In-house product testing and quality control engineers.
- Member of ACI, AITC, ASTM, ASCE, CAMA, CSI, ICC, ICRI, NBMDA, NLBMDA, PATMI, SETMA, STAFDA, NFBA, WTCA and local organizations.
- Various D.O.T. approvals.

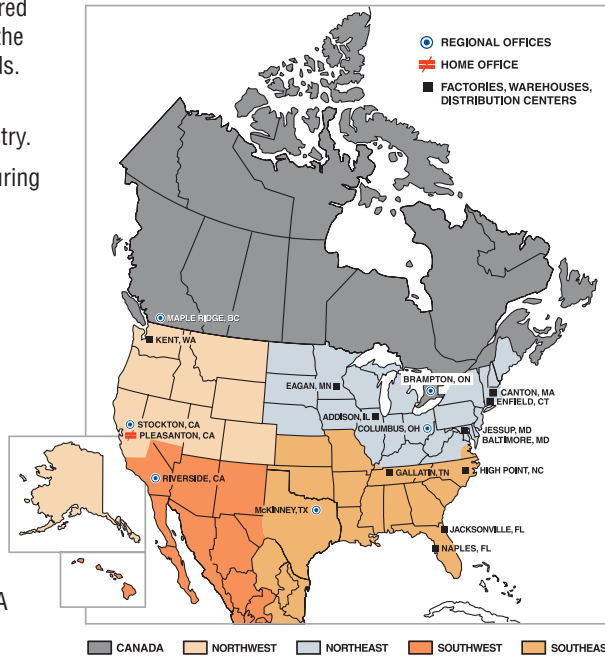

Every day we work hard to earn your business, blending the talents of our people with the quality of our products and services to exceed your expectations.

Simpson Strong-Tie QUALITY POLICY

We help people build safer structures economically. We do this by designing, engineering and manufacturing “No Equal” structural connectors and other related products that meet or exceed our customers’ needs and expectations.

Everyone is responsible for product quality and is committed to ensuring the effectiveness of the Quality Management System.

Karen Colonias
Karen Colonias
Chief Executive Officer

Terry Kingsfather
Terry Kingsfather
President

WE ARE ISO 9001-2000 REGISTERED



Product Selection Key

Products are divided into eight general categories, identified by tabs along the page's outer edge

Epoxy Anchoring Adhesives

15-51 ▶

Acrylic Anchoring Adhesive

52-71 ▶

Adhesive Accessories

72-78 ▶

Vinylester Anchoring Adhesive

79-83 ▶

Crack Repair Adhesives

84-94 ▶

Mechanical Anchors

95-177 ▶

Gas and Powder-Actuated Fastening Systems

178-214 ▶

Carbide Drill Bits and Chisels

215-223 ▶

Special Section:
Connectors for Cold-Formed Steel Curtain-Wall Construction 240-251

Important Information and General Notes

Terms and Conditions of Sale

Product Use

Products in this catalog are designed and manufactured for the specific purposes shown and should not be used in construction not approved by a qualified designer. Modifications to products or changes in installation procedures should only be made by a qualified designer. The performance of such modified products or altered installation procedures is the sole responsibility of the designer.

Indemnity

Customers modifying products or installation procedures, or designing non-catalog products for fabrication by Simpson Strong-Tie Company Inc. shall, regardless of specific instructions to the user, indemnify, defend, and hold harmless Simpson Strong-Tie Company Inc. for any and all claimed loss or damage occasioned in whole or in part by non-catalog or modified products.

Non-Catalog and Modified Products

Consult Simpson Strong-Tie Company Inc. for product applications for which there is no catalog information, or for anchors or fasteners

for use in hostile environments, or with abnormal loading or erection requirements.

Non-catalog products must be designed by the customer and will be fabricated by Simpson Strong-Tie® in accordance with customer specifications.

Simpson Strong-Tie® cannot and does not make any representations regarding the suitability of use or load-carrying capacities of non-catalog products. Simpson Strong-Tie® provides no warranty, express or implied, on non-catalog products.

F.O.B. Shipping Point unless otherwise specified.

Special Order Products

Some products can be ordered as special sizes or with other modifications. Contact Simpson Strong-Tie® for information on special order products. Additional lead time and charges may apply. Special order products are non-cancellable, non-refundable and non-returnable.

Limited Warranty

Simpson Strong-Tie Company Inc. warrants catalog products to be free from substantial defects in material or manufacturing. Simpson Strong-Tie Company Inc. products are further warranted for adequacy of design when used in accordance with design limits in this catalog and when properly specified, installed, and maintained. This warranty does not apply to uses not in compliance with specific applications and installation procedures set forth in this catalog, or to non-catalog or modified products, or to deterioration due to environmental conditions.

Simpson Strong-Tie® products are designed to enable structures to resist the movement, stress, and loading that results from impact events such as earthquakes and high velocity winds. Simpson Strong-Tie products are designed to the load capacities and uses listed in this catalog. Properly-installed Simpson Strong-Tie products will perform substantially in accordance with the specifications set forth on the website or in the applicable Simpson Strong-Tie catalog. Additional performance limitations for specific products may be listed on the applicable catalog pages.

Due to the particular characteristics of potential impact events, the specific design and location of the structure, the building

materials used, the quality of construction, and the condition of the soils involved, damage may nonetheless result to a structure and its contents even if the loads resulting from the impact event do not exceed Simpson Strong-Tie® catalog specifications and Simpson Strong-Tie products are properly installed in accordance with applicable building codes.

All warranty obligations of Simpson Strong-Tie Company Inc. shall be limited, at the discretion of Simpson Strong-Tie Company Inc., to repair or replacement of the defective part. These remedies shall constitute Simpson Strong-Tie Company Inc.'s sole obligation and sole remedy of purchaser under this warranty. In no event will Simpson Strong-Tie Company Inc. be responsible for incidental, consequential, or special loss or damage, however caused.

This warranty is expressly in lieu of all other warranties, expressed or implied, including warranties of merchantability or fitness for a particular purpose, all such other warranties being hereby expressly excluded. This warranty may change periodically – consult our website (www.strongtie.com) for current information.

Warning

Simpson Strong-Tie Company Inc. structural connectors, anchors and other products are designed and tested to provide specified design loads. To obtain optimal performance from Simpson Strong-Tie Company Inc. products and achieve maximum allowable design load and design strength, the products must be properly installed and used in accordance with the installation instructions and design limits provided by Simpson Strong-Tie Company Inc. To ensure proper installation and use, designers and installers must carefully read the following General Notes, General Instructions for the Installer and General Instructions for the Designer as well as consult the applicable catalog pages for specific product installation instructions and notes. If you do not understand the catalog, or if you have any questions, contact Simpson Strong-Tie Company Inc. for further information.

In addition to following all notes, warnings and instructions provided in the catalog, installers, designers, engineers and consumers

should consult the Simpson Strong-Tie Company Inc. web site at www.strongtie.com to obtain additional design and installation information.

Failure to follow fully all of the notes and instructions provided by Simpson Strong-Tie Company Inc. may result in improper design or installation of products. Improperly designed or installed products may not perform to the specifications set forth in this catalog and may reduce a structure's ability to resist the movement, stress and loading that occurs from gravity loads as well as impact events such as earthquakes and high velocity winds.

Simpson Strong-Tie Company Inc. does not guarantee the performance or safety of products that are modified, improperly installed, or not used in accordance with the design and load limits set forth in this catalog.

Important Information and General Notes

Simpson Strong-Tie publishes its *Anchoring and Fastening Systems for Concrete and Masonry* catalog every two years. In an effort to continue to provide our customers with current information on our ever-expanding product line, we publish an addendum on years we don't print a catalog. The addendum will contain new product information, updated testing information and any other information needed to keep our customers up to date with our product line.

Technical Support

When you call for engineering technical support, we can help you if you have the following information at hand. This will help us to serve you promptly and efficiently.

- What Simpson Strong-Tie® catalog are you using? (See the front cover for the form number).
- Which Simpson Strong-Tie product are you considering?
- What are the design requirements? (e.g. loads, anchor diameter, base material, edge/spacing distance, etc.).

**For the most up-to-date information about our products, visit our website at:
www.strongtie.com**

Our toll-free technical support number is (800) 999-5099

*This catalog reflects changes in the loads and configurations of some Simpson Strong-Tie Company Inc. products. This catalog is effective until **December 31, 2014**, and supersedes all information in all earlier publications, including catalogs, brochures, fliers, technical bulletins, etc. Information on loads and configurations is updated periodically.*

Corrosion Information

Understanding The Issues

Metal fasteners and anchors will corrode and may lose load-carrying capacity when installed in corrosive environments or exposed to corrosive materials. There are many environments and materials which may cause corrosion including ocean-salt air, fire retardants, fumes, fertilizers, preservative-treated wood, de-icing salts, dissimilar metals, and other corrosive elements.

The many variables present in a single building environment make it impossible to accurately predict if, or when, significant corrosion will begin or reach a critical level. This relative uncertainty makes it crucial that Designers and users be knowledgeable of the potential risks and select a product coating or metal suitable for the intended use. It is also important that regular maintenance and periodic inspections are performed, especially for outdoor applications.

It is common to see some corrosion especially in outdoor applications. Even stainless steel can corrode. The presence of some corrosion does not mean that load capacity has necessarily been affected or that a failure will occur. If significant corrosion is apparent or suspected, then the wood, anchors and fasteners should be inspected by a qualified professional engineer or qualified general contractor and may need to be replaced.

Preservative-treated wood formulations have changed significantly, and some of the new formulations are more corrosive to anchors and fasteners than the traditionally used formulation of CCA-C. Simpson Strong-Tie testing has shown that ACQ-C, ACQ-D (Carbonate) and CA-B treated woods are approximately two times more corrosive than CCA-C, while SBX-DOT (Sodium Borate) treated woods were shown to be less corrosive than CCA-C. (See technical bulletin T-PTWOOD for details).

Due to the many different preservative-treatment formulations, fluctuating retention levels, moisture content, and because the formulations may vary regionally, or change without warning, understanding which anchors or fasteners to use with these materials has become a complex task. We have attempted to provide basic knowledge on the subject here, but it is important to fully educate yourself by reviewing our technical bulletins on the topic, and also by viewing information and literature provided by others. Additionally, because the issue is evolving it is important to get the very latest information on the topic by visiting our website at www.strongtie.com/info.

Types 304/316 stainless steel are the most effective options to mitigate corrosion risk. However, they are more expensive and sometimes more difficult to obtain. To best serve our customers, Simpson Strong-Tie Company Inc. is evaluating the options to identify the safest and most cost-effective solutions. Based on our testing and experience, there are some specific applications that are appropriate for zinc-plated, mechanically galvanized (Class 55 and 65), hot-dip galvanized, Type 410 stainless steel with a protective top coat, and Type 304/316 stainless-steel anchors or fasteners (see page 12).

Corrosion Information

General Simpson Strong-Tie Recommendations

Outdoor environments are generally more corrosive to steel. If you choose to use mechanically galvanized (Class 55 and 65) on an outdoor project, you should periodically inspect your anchors and fasteners or have a professional inspection performed. Regular maintenance including water-proofing of the wood used in your outdoor project is also a good practice.

For wood with actual retention levels greater than 0.40 pcf for ACQ, 0.34 for MCQ, 0.21 pcf for CA-B, 0.15 pcf for CA-C and MCA or 0.14 pcf for μ CA-C (Ground Contact), stainless-steel anchors and fasteners are recommended. Verify actual retention level with the wood treater.

Testing indicates wood installed dry reduces potential corrosion. If dry wood is used, see our website for additional information.

Due to the many variables involved, Simpson Strong-Tie Company Inc. cannot provide estimates on service life of connectors, anchors or fasteners. We suggest that all users and Specifiers also obtain recommendations for mechanically galvanized (Class 55 and 65) or other coatings from the treated-wood supplier for the type of wood used. However, as long as Simpson Strong-Tie Company Inc. recommendations are followed, Simpson Strong-Tie Company Inc. stands behind its product performance and our standard warranty (page 10) applies.

Guidelines for Selecting the Proper Anchor or Fastener Coating/Material

- 1. Evaluate the Application.** Consider the type of connection and how critical it is. These recommendations may not apply to non-structural applications such as fences.
- 2. Evaluate the Environment.** Testing and experience indicate that indoor dry environments are less corrosive than outdoor environments. Determining the type of environment where an anchor or a fastener will be used is an important factor in selecting the most appropriate material and coating for anchor or fastener use. To help in your decision making, consider the following general exposure information:
 - Interior Dry Use:** Includes wall and ceiling cavities, and raised floor applications in enclosed buildings that have been designed to ensure that condensation and other sources of moisture do not develop.
 - Exterior:** Includes outdoor construction in conditions other than Higher Exposure Use.
 - Higher Exposure Use:** Includes exposure to ocean salt air, de-icing salts, fire retardants, large bodies of water (e.g. dock boards), fumes, fertilizers, soil, some preservative-treated woods, industrial zones, acid rain, and other corrosive elements.
- 3. Evaluate the material to be fastened.** When fastening most untreated wood and other common building materials, additional corrosion risk caused by the fastened material is not a significant factor. Although when fastening dissimilar metals carefully consider the correct combination of fastener and material necessary to avoid galvanic corrosion. For

preservative-treated wood applications, proceed to step four otherwise proceed to step five.

- 4. Familiarize yourself with the preservative-treated wood to be fastened.** The preservative-treated-wood supplier should provide all of the pertinent information about the wood being used. This information should include the specific type of wood treatment used, if ammonia was used in the treatment and the chemical retention level. If this information is not available, then Simpson Strong-Tie Company Inc. recommends the use of types 304 or 316 stainless steel. It is also advisable to obtain a recommendation from the treated-wood supplier for a fastener coating or material that is suitable for use with their formulation in the intended environment. If this recommendation differs from those shown in the table below, Simpson Strong-Tie Company Inc. recommends that the most conservative recommendation be followed.
- 5. Use the chart below, which is based on Simpson Strong-Tie testing and experience, to select the anchor or fastener coating or material.** If the material or preservative-treated wood product to be used is not shown on the chart, Simpson Strong-Tie has not evaluated it and cannot make any other recommendation than the use of coatings/materials shown in the "high" category shown below. Manufacturers may independently provide test results or other product use information; Simpson Strong-Tie Company Inc. expresses no opinion regarding such information.

Minimum Coating or Material Recommendation

Coating/Material Classification

- Low** – Use Simpson Strong-Tie® zinc plated anchors or fasteners as a minimum.
- Med** – Use MG (ASTM B695, Class 55 or 65), HDG or Type 410 stainless steel with a protective top coat as a minimum.
- High** – Use Type 304 or 316 stainless steel anchors and fasteners as a minimum.

Environment	Material to be Fastened							ACZA	Other or Uncertain
	Untreated Wood or Other Material	Preservative-Treated Wood							
		SBX/DOT & Zinc Borate	MCQ/MCA	ACQ-C, ACQ-D (Carbonate), CA-B, CA-C/ μ CA-C					
			Without Ammonia	With Ammonia	Higher Chemical Content				
Interior Dry	Low	Low	Low	Med	Med	High	High	High	
Exterior ⁷	Med	N/A ²	Med ^{3,4}	Med ^{3,4}	High	High	High	High	
Higher Exposure ⁷	High	N/A ²	High	High	High	High	High	High	
Uncertain ⁷	High	High ²	High	High	High	High	High	High	

- Wood with actual retention levels greater than 0.40 pcf for ACQ, 0.34 for MCQ, 0.21 pcf for CA-B, 0.15 pcf for CA-C and MCA or 0.14 pcf for μ CA-C (Ground Contact), stainless-steel anchors and fasteners are recommended. Verify actual retention level with the wood treater.
- Borate treated woods are not appropriate for outdoor use.
- Test results indicate that hot-dip galvanized and mechanically galvanized (class 55 and 65) will perform adequately, subject to regular maintenance and periodic inspection. However, the test protocol followed was a modified version of the nationally recognized test method AWWA E12-94. This test method is an accelerated test, so data over an extended period of time is not available. Also noteworthy is that tests run in a laboratory may not correlate to service conditions. If uncertain, use types 304/316 stainless steel.
- Some treated wood may have excess surface chemicals making it potentially more corrosive. If you suspect this or are uncertain, use types 304/316 stainless steel.
- Ammonia is typically used as a chemical carrier for difficult to treat wood species, such as, but not exclusive to, Douglas Fir and Hem Fir, which are usually found in the western United States. Amine carriers are used in some of the eastern species, such as Southern Yellow Pine. If uncertain, verify chemical with wood treater.
- Type 316 stainless-steel fasteners are the minimum recommendation for ocean-salt air and other chloride environments.
- Mechanically galvanized Titen HD® Anchors are only recommended for temporary exterior applications.

For the latest Simpson Strong-Tie® coating information and additional technical information on this topic, visit our website at www.strongtie.com/info.

Important Information and General Notes

Table Icon System

In order to facilitate easier identification of performance data, the following icon system has been incorporated into the sections of the catalog with multiple load tables. These icons will appear in the heading of the table to promote easier visual identification of the type of load, insert type and substrate addressed in the table. Icons are intended for quick identification. All specific information regarding suitability should be read from the table itself.

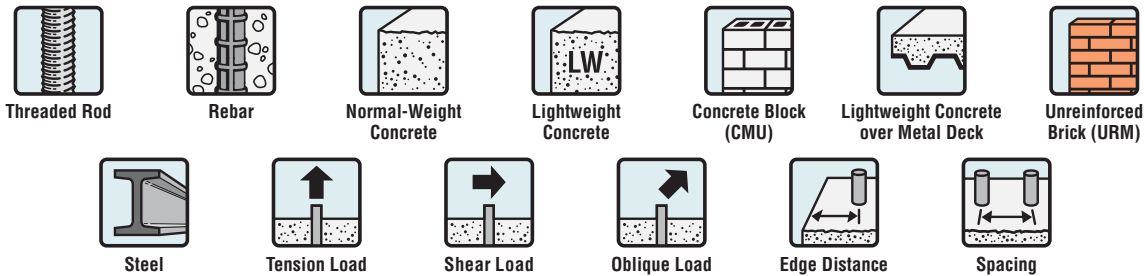

General Notes

These general notes are provided to ensure proper installation of Simpson Strong-Tie Company Inc products and must be followed fully.

- a. Simpson Strong-Tie Company Inc. reserves the right to change specifications, designs, and models without notice or liability for such changes.
- b. Unless otherwise noted, dimensions are in inches and loads are in pounds.
- c. Do not overload, which will jeopardize the anchorage. Service loads shall not exceed published allowable loads. Factored loads shall not exceed design strengths calculated in accordance with published design data.
- d. Some hardened fasteners may experience premature failure if exposed to moisture. These fasteners are recommended to be used in dry interior applications.
- e. Do not weld products listed in this catalog. Some steel types have poor weldability and a tendency to crack when welded.

General Instructions for the Installer

These general instructions for the installer are provided to ensure the proper selection and installation of Simpson Strong-Tie Company Inc. products and must be followed carefully. These general instructions are in addition to the specific design and installation instructions and notes provided for each particular product, all of which should be consulted prior to and during the installation of Simpson Strong-Tie Company Inc. products.

- a. Do not modify Simpson Strong-Tie Company Inc. products. The performance of modified products may be substantially weakened. Simpson Strong-Tie will not warrant or guarantee the performance of such modified products.
- b. Do not alter installation procedures from those set forth in this catalog.
- c. Drill holes for mechanical anchors with carbide-tipped drill bits meeting the diameter requirements of ANSI B212.15 shown in the table provided. A properly-sized hole is critical to the performance of mechanical anchors. Rotary-hammer drills with light, high-frequency impact are recommended for drilling holes. When holes are to be drilled in archaic or hollow base materials, the drill should be set to "rotation-only" mode.
- d. For mechanical anchors that require a specific installation torque: Failure to apply the recommended installation torque can result in excessive displacement of the anchor under load or premature failure of the anchor. These anchors will lose pre-tension after setting due to pre-load relaxation. See Supplemental Topic M1 on page 225 for more information.
- e. Do not disturb, bolt up, or apply load to adhesive anchors prior to the full cure of the adhesive.
- f. For gas- or powder-actuated fastening, refer to the Important Information on page 187.
- g. Use proper safety equipment.

Finished Diameters for Rotary and Rotary Hammer Carbide Tipped Concrete Drills per ANSI B212.15

Nominal Drill Bit Diameter (in.)	Tolerance Range Minimum (in.)	Tolerance Range Maximum (in.)
1/8	0.134	0.140
5/32	0.165	0.171
3/16	0.198	0.206
7/32	0.229	0.237
1/4	0.260	0.268
5/16	0.327	0.335
3/8	0.390	0.398
7/16	0.458	0.468
1/2	0.520	0.530
9/16	0.582	0.592
5/8	0.650	0.660
11/16	0.713	0.723
3/4	0.775	0.787
13/16	0.837	0.849
27/32	0.869	0.881
7/8	0.905	0.917
15/16	0.968	0.980
1	1.030	1.042
1 1/8	1.160	1.175
1 3/16	1.223	1.238
1 1/4	1.285	1.300
1 5/16	1.352	1.367
1 3/8	1.410	1.425
1 7/16	1.472	1.487
1 1/2	1.535	1.550
1 9/16	1.588	1.608
1 5/8	1.655	1.675
1 3/4	1.772	1.792
2	2.008	2.028

Important Information and General Notes

General Instructions for the Designer

These general instructions for the designer are provided to ensure the proper selection and installation of Simpson Strong-Tie Company Inc. products and must be followed carefully. These general instructions are in addition to the specific design and installation instructions and notes provided for each particular product, all of which should be consulted prior to and during the design process.

- a. The term “Designer” used throughout this catalog is intended to mean a licensed/certified building design professional, a licensed professional engineer, or a licensed architect.
- b. All connected members and related elements shall be designed by the Designer and must have sufficient strength (bending, shear, etc) to resist the loads imposed by the anchors.
- c. When the allowable stress design method is used, the design service loads shall not exceed the published allowable loads reduced by load-adjustment factors for temperature, spacing and edge distance as applicable.
- d. When the strength design method is used, reduced by load-adjustment factors for temperature, spacing, and edge distance, as applicable, the factored loads shall not exceed the design strengths calculated in accordance with the published design data.
- e. Simpson Strong-Tie® strongly recommends the following addition to construction drawings and specifications: “Simpson Strong-Tie products are specifically required to meet the structural calculations of plan. Before substituting another brand, confirm load capacity based on reliable published testing data or calculations. The Engineer/Designer of Record should evaluate and give written approval for substitution prior to installation.”
- f. Local and/or regional building codes may require meeting special conditions. Building codes often require special inspections of anchors installed in concrete or masonry. For compliance with these requirements, it is necessary to contact the local and/or regional building authority. Except where mandated by code, Simpson Strong-Tie® products do not require special inspection.
- g. Allowable loads and design strengths are determined from test results, calculations, and experience. These are guide values for sound base materials with known properties. Due to variation in base materials and site conditions, site-specific testing should be conducted if exact performance in a specific base material at a specific site must be known.
- h. Unless stated otherwise, tests conducted to derive performance information were performed in members with minimum thickness equal to 1.5 times the anchor embedment depth. Anchoring into thinner members requires the evaluation and judgment of a qualified Designer.
- i. Tests are conducted with anchors installed perpendicular ($\pm 6^\circ$ from a vertical reference) from a vertical reference to the surface of the base material. Deviations can result in anchor bending stresses and reduce the load carrying capacity of the anchor.
- j. Allowable loads and design strengths do not consider bending stresses due to shear loads applied with large eccentricities.
- k. Metal anchors and fasteners will corrode and may lose load-carrying capacity when installed in corrosive environments or exposed to corrosive materials. See Supplemental Topic G3.
- l. Mechanical anchors should not be installed into concrete that is less than 7 days old. The allowable loads and design strengths of mechanical anchors that are installed into concrete less than 28 days old should be based on the actual compressive strength of the concrete at the time of installation.
- m. Nominal embedment depth (embedment depth) is the distance from the surface of the base material to the installed end of the anchor and is measured prior to application of an installation torque (if applicable). Effective embedment depth is the distance from the surface of the base material to the deepest point at which the load is transferred to the base material.
- n. Drill bits shall meet the diameter requirements of ANSI B212.15. For adhesive anchor installations in oversized holes, see Supplemental Topic A1. For adhesive anchor installations into core-drilled holes, see Supplemental Topic A2.
- o. Threaded-rod inserts for adhesive anchors shall be UNC fully threaded steel.
- p. Allowable loads and design strengths are generally based on testing of adhesive anchors installed into dry holes. For installations in damp, wet and submerged environments, see Supplemental Topic A3.
- q. Adhesive anchors should not be installed into concrete that is less than 7 days old. The allowable loads and design strengths of adhesive anchors that are installed into concrete less than 28 days old should be based on the actual compressive strength of the concrete at the time load is applied.
- r. Adhesive anchors can be affected by elevated base material temperature. See Supplemental Topic A4.
- s. Anchors are permitted to support fire-resistive construction provided at least one of the following conditions is fulfilled:
 - a) Anchors are used to resist wind or seismic forces only;
 - b) Anchors that support gravity load-bearing structural elements are within a fire-resistance-rated envelope or a fire-resistance-rated membrane, are protected by approved fire-resistance rated materials, or have been evaluated for resistance to fire exposure in accordance with recognized standards;
 - c) Anchors are used to support nonstructural elements.
- t. Some adhesives are not qualified for resisting long-term sustained loads. These adhesives are for resisting short-term loads such as wind or seismic loads only. See Supplemental Topic A5.
- u. Exposure to some chemicals may degrade the bond strength of adhesive anchors. Refer to the product description for chemical resistance information. Information is also available in Simpson Strong-Tie Company Inc. Technical Bulletin T-SAS-CHEMRES.

Epoxy Anchoring Adhesives

Ideal for anchoring threaded rod, rebar and smooth dowels in a variety of base materials, epoxy-based anchoring adhesives offer strength and versatility across a wide variety of applications. Simpson Strong-Tie[®] epoxy adhesives meet or are rigorously tested to meet 2009 IBC requirements for both cracked and uncracked concrete applications. As you would expect, Simpson Strong-Tie offers all the high-strength dispensing tools and other important accessories to increase productivity on any project.





SET-XP® High-Strength Anchoring Adhesive for Cracked and Uncracked Concrete

Epoxy Adhesives

SET-XP® is a 1:1 two-component, high-solids, epoxy-based anchoring adhesive formulated for optimum performance in both cracked and uncracked concrete. SET-XP® adhesive has been rigorously tested in accordance with ICC-ES AC308 and 2009 IBC requirements and has proven to offer increased reliability in the most adverse conditions, including performance in cracked concrete under static and seismic loading. SET-XP® adhesive is teal in color in order to be identified as a high-performance adhesive for adverse conditions. Resin and hardener are dispensed and mixed simultaneously through the mixing nozzle. SET-XP® adhesive exceeds the ASTM C881 specification for Type I and Type IV, Grade 3, Class C epoxy.

USES: When SET-XP® adhesive is used with all threaded rod or rebar, the system can be used in tension and seismic zones where there is a risk of cracks occurring that pass through the anchor location. It is also suitable for uncracked concrete conditions.

CODES: ICC-ES ESR-2508; City of L.A. pending; Florida FL 11506.5 NSF/ANSI Standard 61 (216 in²/1000 gal). The load tables list values based upon results from the most recent testing and may not reflect those in current code reports. Where code jurisdictions apply, consult the current reports for applicable load values.

APPLICATION: Surfaces to receive epoxy must be clean. The base-material temperature must be 50° F or above at the time of installation. For best results, material should be 70–80° F at the time of application. Cartridges should not be immersed in water to facilitate warming. To warm cold material, the cartridges should be stored in a warm, uniformly-heated area or storage container for a sufficient time to allow epoxy to warm completely. Mixed material in nozzle can harden in 5–7 minutes at a temperature of 40° F or above.

DESIGN EXAMPLE: See pages 231, 235–237

INSTALLATION: See pages 70–71

SHELF LIFE: 24 months from date of manufacture in unopened side-by-side cartridge.

STORAGE CONDITIONS: For best results, store between 45–90° F. To store partially used cartridges, leave hardened nozzle in place. To re-use, attach new nozzle.

COLOR: Resin – white, hardener – black-green. When properly mixed, SET-XP adhesive will be a uniform teal color.

CLEAN UP: Uncured material – Wipe up with cotton cloths. If desired, scrub area with abrasive, waterbased cleaner and flush with water. If approved, solvents such as ketones (MEK, acetone, etc.), lacquer thinner or adhesive remover can be used. **DO NOT USE SOLVENTS TO CLEAN ADHESIVE FROM SKIN.** Take appropriate precautions when handling flammable solvents. Solvents may damage surfaces to which they are applied. Cured Material – chip or grind off surface.

TEST CRITERIA: Anchors installed with SET-XP® adhesive have been tested in accordance with ICC-ES's Acceptance Criteria for Post-Installed Adhesive Anchors in Masonry Elements (AC58) and Adhesive Anchors in Concrete Elements (AC308) for the following:

- Seismic and wind loading in cracked and uncracked concrete and uncracked masonry
- Static tension and shear loading in cracked and uncracked concrete and uncracked masonry
- Horizontal and overhead installations
- Long-term creep at elevated-temperatures
- Static loading at elevated-temperatures
- Damp holes
- Freeze-thaw conditions
- Critical and minimum edge distance and spacing

PROPERTY	TEST METHOD	RESULTS
Consistency	ASTM C881	Passed, non-sag
Glass transition temperature	ASTM E1356	155°F
Bond strength (moist cure)	ASTM C882	3,742 psi at 2 days
Water absorption	ASTM D570	0.10%
Compressive yield strength	ASTM D695	14,830 psi
Compressive modulus	ASTM D695	644,000 psi
Gel time	ASTM C881	49 minutes

CHEMICAL RESISTANCE: Very good to excellent against distilled water, in-organic acids and alkalis. Fair to good against organic acids and alkalis, and many organic solvents. Poor against ketones. For more detailed information visit our website or contact Simpson Strong-Tie.



SET-XP® 10



SET-XP® 22



SET-XP® 56



EMN22i

EDT22S

SET-XP Cartridge System

Model No.	Capacity ounces (cubic inches)	Cartridge Type	Carton Quantity	Dispensing tool(s)	Mixing Nozzle
SET-XP10	8.5 (16.2)	single	12	CDT10S	EMN22i
SET-XP22	22 (39.7)	side-by-side	10	EDT22S EDTA22P EDT22CKT	
SET-XP56	56 (101.1)	side-by-side	6	EDTA56P	

1. Cartridge estimation guides are available on pages 48–51.
2. Detailed information on dispensing tools, mixing nozzles and other adhesive accessories is available on pages 72–77.
3. Use only appropriate Simpson Strong-Tie mixing nozzle in accordance with Simpson Strong-Tie instructions. Modification or improper use of mixing nozzle may impair epoxy performance.

Cure Schedule

Base Material Temperature		Gel Time (mins.)	Cure Time (hrs.)
°F	°C		
50	10	75	72
60	16	60	48
70	21	45	24
90	32	35	24
110	43	20	24

For water-saturated concrete, the cure times are doubled.

SUGGESTED SPECIFICATION: Anchoring adhesive shall be a two-component high-solids, epoxy-based system supplied in manufacturer's standard cartridge and dispensed through a static-mixing nozzle supplied by the manufacturer. The adhesive anchor shall have been tested and qualified for performance in cracked and uncracked concrete per ICC-ES AC308. Adhesive shall be SET-XP® adhesive from Simpson Strong-Tie, Pleasanton, CA. Anchors shall be installed per Simpson Strong-Tie instructions for SET-XP epoxy adhesive.

ACCESSORIES: See pages 72–77 for information on dispensing tools, mixing nozzles and other accessories.

IMPORTANT – See Pages 70–71 for Installation Instructions

SET-XP® High-Strength Anchoring Adhesive for Cracked and Uncracked Concrete

SET-XP® Epoxy Anchor Installation Information and Additional Data for Threaded Rod and Rebar in Normal-Weight Concrete¹

Characteristic	Symbol	Units	Nominal Anchor Diameter (in.) / Rebar Size						
			3/8 / #3	1/2 / #4	5/8 / #5	3/4 / #6	7/8 / #7	1 / #8	1 1/4 / #10
Installation Information									
Drill Bit Diameter	d_{hole}	in.	1/2	5/8	3/4	7/8	1	1 1/8	1 3/8
Maximum Tightening Torque	T_{inst}	ft-lb	10	20	30	45	60	80	125
Permitted Embedment Depth Range ²	Minimum	h_{ef}	2 3/8	2 3/4	3 1/8	3 1/2	3 3/4	4	5
	Maximum	h_{ef}	7 1/2	10	12 1/2	15	17 1/2	20	25
Minimum Concrete Thickness	h_{min}	in.	$h_{ef} + 5d_o$						
Critical Edge Distance	c_{ac}	in.	$3 \times h_{ef}$						
Minimum Edge Distance	c_{min}	in.	1 3/4						
Minimum Anchor Spacing	s_{min}	in.	3						

- The information presented in this table is to be used in conjunction with the design criteria of ICC-ES AC308.
- Minimum and maximum embedment depths are listed in accordance with ICC-ES AC308 requirements.



SET-XP Epoxy Anchor Tension Strength Design Data for Threaded Rod in Normal-Weight Concrete^{1,12}

Characteristic	Symbol	Units	Nominal Anchor Diameter (in.)							
			3/8	1/2	5/8	3/4	7/8	1	1 1/4	
Steel Strength in Tension										
Threaded Rod	Minimum Tensile Stress Area	A_{se}	in ²	0.078	0.142	0.226	0.334	0.462	0.606	0.969
	Tension Resistance of Steel - ASTM A193, Grade B7	N_{sa}	lb.	9,750	17,750	28,250	41,750	57,750	75,750	121,125
	- ASTM F1554, Grade 36			4,525	8,235	13,110	19,370	26,795	35,150	56,200
	- Type 410 Stainless (ASTM A193, Grade B6)			8,580	15,620	24,860	36,740	50,820	66,660	106,590
	- Type 304 and 316 Stainless (ASTM A193, Grade B8 and B8M)			4,445	8,095	12,880	19,040	26,335	34,540	55,235
Strength Reduction Factor - Steel Failure	ϕ	—	0.75 ⁹							
Concrete Breakout Strength in Tension (2,500 psi ≤ f'_c ≤ 8,000 psi)¹⁵										
Effectiveness Factor - Uncracked Concrete	k_{uncr}	—	24							
Effectiveness Factor - Cracked Concrete	k_{cr}	—	17							
Strength Reduction Factor - Breakout Failure	ϕ	—	0.65 ¹¹							
Bond Strength in Tension (2,500 psi ≤ f'_c ≤ 8,000 psi)¹⁵										
Temp. Range 1 for Uncracked Concrete ^{2,4,5}	Characteristic Bond Strength ⁸	$\tau_{k,uncr}$	psi	1,510	2,250	2,075	1,905	1,730	1,555	1,205
	Permitted Embedment Depth Range	Minimum	h_{ef}	in	2 3/8	2 3/4	3 1/8	3 1/2	3 3/4	4
Maximum		7 1/2			10	12 1/2	15	17 1/2	20	25
Temp. Range 1 for Cracked Concrete ^{2,4,5}	Characteristic Bond Strength ^{8,13,14}	$\tau_{k,cr}$	psi	1,165	995	855	760	700	675	675
	Permitted Embedment Depth Range	Minimum	h_{ef}	in	3	4	5	6	7	8
Maximum		7 1/2			10	12 1/2	15	17 1/2	20	25
Temp. Range 2 for Uncracked Concrete ^{3,4,5}	Characteristic Bond Strength ^{6,8}	$\tau_{k,uncr}$	psi	780	1,160	1,070	980	895	800	625
	Permitted Embedment Depth Range	Minimum	h_{ef}	in	2 3/8	2 3/4	3 1/8	3 1/2	3 3/4	4
Maximum		7 1/2			10	12 1/2	15	17 1/2	20	25
Temp. Range 2 for Cracked Concrete ^{3,4,5}	Characteristic Bond Strength ^{6,8,13,14}	$\tau_{k,cr}$	psi	600	515	440	390	360	350	350
	Permitted Embedment Depth Range	Minimum	h_{ef}	in	3	4	5	6	7	8
Maximum		7 1/2			10	12 1/2	15	17 1/2	20	25
Bond Strength in Tension – Bond Strength Reduction Factors for Continuous Special Inspection										
Strength Reduction Factor - Dry Concrete	$\phi_{dry,ci}$	—	0.65 ¹⁰							
Strength Reduction Factor - Water-saturated Concrete	$\phi_{sat,ci}$	—	0.45 ¹⁰							
Additional Factor for Water-saturated Concrete ⁷	$K_{sat,ci}$	—	0.57							
Bond Strength in Tension – Bond Strength Reduction Factors for Periodic Special Inspection										
Strength Reduction Factor - Dry Concrete	$\phi_{dry,pi}$	—	0.55 ¹⁰							
Strength Reduction Factor - Water-saturated Concrete	$\phi_{sat,pi}$	—	0.45 ¹⁰							
Additional Factor for Water-saturated Concrete ⁷	$K_{sat,pi}$	—	0.48							

- The information presented in this table is to be used in conjunction with the design criteria of ICC-ES AC308, except as modified below.
- Temperature Range 1: Maximum short-term temperature of 110°F (43°C). Maximum long-term temperature of 75°F (24°C).
- Temperature Range 2: Maximum short-term temperature of 150°F (66°C). Maximum long-term temperature of 110°F (43°C).
- Short-term concrete temperatures are those that occur over short intervals (diurnal cycling).
- Long-term concrete temperature are constant temperatures over a significant time period.
- For anchors that only resist wind or seismic loads, bond strengths may be increased by 72%.
- In water-saturated concrete, multiply $\tau_{k,uncr}$ and $\tau_{k,cr}$ by K_{sat} .
- For anchors installed in overhead and subjected to tension resulting from sustained loading, multiply the value calculated for N_a according to ICC-ES AC308 by 0.75.
- The value of ϕ applies when the load combinations of ACI 318 Section 9.2 are used. If the load combinations of ACI 318 Appendix C are used, refer to Section D.4.5 to determine the appropriate value of ϕ .
- The value of ϕ applies when both the load combinations of ACI 318 Section 9.2 are used and the requirements of Section D.4.4(c) for Condition B are met. If the load combinations of ACI 318 Appendix C are used, refer to Section D.4.5 to determine the appropriate value of ϕ .
- The value of ϕ applies when both the load combinations of ACI 318 Section 9.2 are used and the requirements of Section D.4.4(c) for Condition B are met. If the load combinations of ACI 318 Section 9.2 are used and the requirements of Section D.4.4(c) for Condition A are met, refer to Section D.4.4 to determine the appropriate value of ϕ . If the load combinations of ACI 318 Appendix C are used, refer to Section D.4.5 to determine the appropriate value of ϕ .
- Sand-lightweight and all-lightweight concrete are beyond the scope of this table.
- For anchors installed in regions assigned to Seismic Design Category C, D, E or F, the bond strength values for 7/8" anchors must be multiplied by $\alpha_{N,seis} = 0.80$.
- For anchors installed in regions assigned to Seismic Design Category C, D, E or F, the bond strength values for 1" anchors must be multiplied by $\alpha_{N,seis} = 0.92$.
- The values of f'_c used for calculation purposes must not exceed 8000 psi (55.1 MPa) for uncracked concrete. The value of f'_c used for calculation purposes must not exceed 2,500 psi (17.2 MPa) for tension resistance in cracked concrete.

SET-XP® High-Strength Anchoring Adhesive for Cracked and Uncracked Concrete

Epoxy Adhesives



SET-XP® Epoxy Anchor Tension Strength Design Data for Rebar in Normal-Weight Concrete^{1,12}

Characteristic		Symbol	Units	Rebar Size								
				#3	#4	#5	#6	#7	#8	#10		
Steel Strength in Tension												
Rebar	Minimum Tensile Stress Area	A_{se}	in ²	0.11	0.20	0.31	0.44	0.60	0.79	1.23		
	Tension Resistance of Steel - Rebar (ASTM A615, Grade 60)	N_{sa}	lb.	9,900	18,000	27,900	39,600	54,000	71,100	110,700		
	Strength Reduction Factor - Steel Failure	ϕ	—	0.65 ⁹								
Concrete Breakout Strength in Tension (2,500 psi ≤ f_c ≤ 8,000 psi)¹⁵												
Effectiveness Factor - Uncracked Concrete		k_{uncr}	—	24								
Effectiveness Factor - Cracked Concrete		k_{cr}	—	17								
Strength Reduction Factor - Breakout Failure		ϕ	—	0.65 ¹¹								
Bond Strength in Tension (2,500 psi ≤ f_c ≤ 8,000 psi)¹⁵												
Temp. Range 1 for Uncracked Concrete ^{2,4,5}	Characteristic Bond Strength ⁸		$\tau_{k,uncr}$	psi	1600							
	Permitted Embedment Depth Range		Minimum	h_{ef}	in	2 3/4	2 3/4	3 1/8	3 1/2	3 3/4	4	5
		Maximum	7 1/2			10	12 1/2	15	17 1/2	20	25	
Temp. Range 1 for Cracked Concrete ^{2,4,5}	Characteristic Bond Strength ^{8,13,14}		$\tau_{k,cr}$	psi	1,165	995	855	760	700	675	675	
	Permitted Embedment Depth Range		Minimum	h_{ef}	in	3	4	5	6	7	8	10
		Maximum	7 1/2			10	12 1/2	15	17 1/2	20	25	
Temp. Range 2 for Uncracked Concrete ^{3,4,5}	Characteristic Bond Strength ^{6,8}		$\tau_{k,uncr}$	psi	825							
	Permitted Embedment Depth Range		Minimum	h_{ef}	in	2 3/8	2 3/4	3 1/8	3 1/2	3 3/4	4	5
		Maximum	7 1/2			10	12 1/2	15	17 1/2	20	25	
Temp. Range 2 for Cracked Concrete ^{3,4,5}	Characteristic Bond Strength ^{6,8,13,14}		$\tau_{k,cr}$	psi	600	515	440	390	360	350	350	
	Permitted Embedment Depth Range		Minimum	h_{ef}	in	3	4	5	6	7	8	10
		Maximum	7 1/2			10	12 1/2	15	17 1/2	20	25	
Bond Strength in Tension - Bond Strength Reduction Factors for Continuous Special Inspection												
Strength Reduction Factor - Dry Concrete		$\phi_{dry, ci}$	—	0.65 ¹⁰								
Strength Reduction Factor - Water-saturated Concrete		$\phi_{sat, ci}$	—	0.45 ¹⁰								
Additional Factor for Water-saturated Concrete ⁷		$K_{sat, ci}$	—	0.57								
Bond Strength in Tension - Bond Strength Reduction Factors for Periodic Special Inspection												
Strength Reduction Factor - Dry Concrete		$\phi_{dry, pi}$	—	0.55 ¹⁰								
Strength Reduction Factor - Water-saturated Concrete		$\phi_{sat, pi}$	—	0.45 ¹⁰								
Additional Factor for Water-saturated Concrete ⁷		$K_{sat, pi}$	—	0.48								

- The information presented in this table is to be used in conjunction with the design criteria of ICC-ES AC308, except as modified below.
- Temperature Range 1: Maximum short-term temperature of 110°F (43°C). Maximum long-term temperature of 75°F (24°C).
- Temperature Range 2: Maximum short-term temperature of 150°F (66°C). Maximum long-term temperature of 110°F (43°C).
- Short-term concrete temperatures are those that occur over short intervals (diurnal cycling).
- Long-term concrete temperature are constant temperatures over a significant time period.
- For anchors that only resist wind or seismic loads, bond strengths may be increased by 72%.
- In water-saturated concrete, multiply $\tau_{k,uncr}$ and $\tau_{k,cr}$ by K_{sat} .
- For anchors installed in overhead and subjected to tension resulting from sustained loading, multiply the value calculated for N_a according to ICC-ES AC308 by 0.75.
- The value of ϕ applies when the load combinations of ACI 318 Section 9.2 are used. If the load combinations of ACI 318 Appendix C are used, refer to Section D.4.5 to determine the appropriate value of ϕ .
- The value of ϕ applies when both the load combinations of ACI 318 Section 9.2 are used and the requirements of Section D.4.4(c) for Condition B are met. If the load combinations of ACI 318 Appendix C are used, refer to Section D.4.5 to determine the appropriate value of ϕ .
- The value of ϕ applies when both the load combinations of ACI 318 Section 9.2 are used and the requirements of Section D.4.4(c) for Condition B are met. If the load combinations of ACI 318 Appendix C are used, refer to Section D.4.5 to determine the appropriate value of ϕ .
- Sand-lightweight and all-lightweight concrete are beyond the scope of this table.
- For anchors installed in regions assigned to Seismic Design Category C, D, E or F, the bond strength values for #7 rebar anchors must be multiplied by $\alpha_{N,seis} = 0.80$.
- For anchors installed in regions assigned to Seismic Design Category C, D, E or F, the bond strength values for #8 rebar anchors must be multiplied by $\alpha_{N,seis} = 0.92$.
- The values of f'_c used for calculation purposes must not exceed 8000 psi (55.1 MPa) for uncracked concrete. The value of f'_c used for calculation purposes must not exceed 2,500 psi (17.2 MPa) for tension resistance in cracked concrete.

SET-XP® High-Strength Anchoring Adhesive for Cracked and Uncracked Concrete



SET-XP® Epoxy Anchor Shear Strength Design Data for Threaded Rod in Normal-Weight Concrete^{1,5}

Characteristic		Symbol	Units	Nominal Anchor Diameter (in.)						
				3/8	1/2	5/8	3/4	7/8	1	1 1/4
Steel Strength in Shear										
Threaded Rod	Minimum Shear Stress Area	A_{se}	in ²	0.078	0.142	0.226	0.334	0.462	0.606	0.969
	Shear Resistance of Steel - ASTM A193, Grade B7	V_{sa}^6	lb.	4,875	10,650	16,950	25,050	34,650	45,450	72,675
	- ASTM F1554, Grade 36			2,260	4,940	7,865	11,625	16,080	21,090	33,720
	- Type 410 Stainless (ASTM A193, Grade B6) - Type 304 and 316 Stainless (ASTM A193, Grade B8 and B8M)			4,290	9,370	14,910	22,040	30,490	40,000	63,955
	Reduction for Seismic Shear - ASTM F1554, Grade 36 ⁶	$\alpha_{V,seis}$	—	0.87	0.78	0.68	0.68	0.68	0.68	0.65
	Reduction for Seismic Shear - ASTM A193, Grade B7 ⁶			0.87	0.78	0.68	0.68	0.68	0.68	0.65
	Reduction for Seismic Shear - Stainless (ASTM A193, Grade B6) ⁶			0.69	0.82	0.75	0.75	0.75	0.83	0.72
	Reduction for Seismic Shear - Stainless (ASTM A193, Grade B8 and B8M) ⁶			0.69	0.82	0.75	0.75	0.75	0.83	0.72
Strength Reduction Factor - Steel Failure	ϕ	—	0.65 ²							
Concrete Breakout Strength in Shear										
Outside Diameter of Anchor	d_o	in.	0.375	0.500	0.625	0.750	0.875	1.000	1.250	
Load Bearing Length of Anchor in Shear	ℓ_e	in.	h _{ef}							
Strength Reduction Factor - Breakout Failure	ϕ	—	0.70 ³							
Concrete Pryout Strength in Shear										
Coefficient for Pryout Strength	k_{cp}	—	2.0							
Strength Reduction Factor - Pryout Failure	ϕ	—	0.70 ⁴							

- The information presented in this table is to be used in conjunction with the design criteria of ICC-ES AC308, except as modified below.
- The value of ϕ applies when the load combinations of ACI 318 Section 9.2 are used. If the load combinations of AC 318 Appendix C are used, refer to Section D.4.5 to determine the appropriate value of ϕ .
- The value of ϕ applies when both the load combinations of ACI 318 Section 9.2 are used and the requirements of Section D.4.4(c) for Condition B are met. If the load combinations of ACI 318 Section 9.2 are used and the requirements of Section D.4.4(c) for Condition A are met, refer to Section D.4.4 to determine the appropriate value of ϕ . If the load combinations of ACI 318 Appendix C are used, refer to Section D.4.5 to determine the appropriate value of ϕ .
- The value of ϕ applies when both the load combinations of ACI 318 Section 9.2 are used and the requirements of Section D.4.4(c) for Condition B are met. If the load combinations of ACI 318 Appendix C are used, refer to Section D.4.5 to determine the appropriate value of ϕ .
- Sand-lightweight and all-lightweight concrete are beyond the scope of this table.
- The values of V_{sa} are applicable for both cracked and uncracked concrete. For anchors installed in regions assigned to Seismic Design Category C, D, E or F, V_{sa} must be multiplied by $\alpha_{V,seis}$ for the corresponding threaded rod steel type.

SET-XP® Epoxy Anchor Shear Strength Design Data for Rebar in Normal-Weight Concrete^{1,5}



Characteristic		Symbol	Units	Rebar Size						
				#3	#4	#5	#6	#7	#8	#10
Steel Strength in Shear										
Rebar	Minimum Shear Stress Area	A_{se}	in ²	0.11	0.20	0.31	0.44	0.60	0.79	1.23
	Shear Resistance of Steel - Rebar (ASTM A615, Grade 60)	V_{sa}^6	lb.	4,950	10,800	16,740	23,760	32,400	42,660	66,420
	Reduction for Seismic Shear - Rebar (ASTM A615, Grade 60) ⁶	$\alpha_{V,seis}$	—	0.85	0.88	0.84	0.84	0.77	0.77	0.59
	Strength Reduction Factor - Steel Failure	ϕ	—	0.60 ²						
Concrete Breakout Strength in Shear										
Outside Diameter of Anchor	d_o	in.	0.375	0.500	0.625	0.750	0.875	1.000	1.250	
Load Bearing Length of Anchor in Shear	ℓ_e	in.	h _{ef}							
Strength Reduction Factor - Breakout Failure	ϕ	—	0.70 ³							
Concrete Pryout Strength in Shear										
Coefficient for Pryout Strength	k_{cp}	—	2.0							
Strength Reduction Factor - Pryout Failure	ϕ	—	0.70 ⁴							

- The information presented in this table is to be used in conjunction with the design criteria of ICC-ES AC308, except as modified below.
- The value of ϕ applies when the load combinations of ACI 318 Section 9.2 are used. If the load combinations of AC 318 Appendix C are used, refer to Section D.4.5 to determine the appropriate value of ϕ .
- The value of ϕ applies when both the load combinations of ACI 318 Section 9.2 are used and the requirements of Section D.4.4(c) for Condition B are met. If the load combinations of ACI 318 Section 9.2 are used and the requirements of Section D.4.4(c) for Condition A are met, refer to Section D.4.4 to determine the appropriate value of ϕ . If the load combinations of ACI 318 Appendix C are used, refer to Section D.4.5 to determine the appropriate value of ϕ .
- The value of ϕ applies when both the load combinations of ACI 318 Section 9.2 are used and the requirements of Section D.4.4(c) for Condition B are met. If the load combinations of ACI 318 Appendix C are used, refer to Section D.4.5 to determine the appropriate value of ϕ .
- Sand-lightweight and all-lightweight concrete are beyond the scope of this table.
- The values of V_{sa} are applicable for both cracked and uncracked concrete. For anchors installed in regions assigned to Seismic Design Category C, D, E or F, V_{sa} must be multiplied by $\alpha_{V,seis}$.

SET-XP® High-Strength Anchoring Adhesive for Cracked and Uncracked Concrete

Epoxy Adhesives

Tension and Shear Loads for Threaded Rod and Rebar Anchors in 8-inch Lightweight, Medium-Weight and Normal-Weight Grout Filled CMU



* See page 13 for an explanation of the load table icons

Rod Dia. in. (mm)	Drill Bit Dia. in.	Min. Embed. Depth in. (mm)	Critical Edge Dist. in. (mm)	Critical End Dist. in. (mm)	Critical Spacing Dist. in. (mm)	8-inch Grout Filled CMU Allowable Loads Based on CMU Strength			
						Tension		Shear	
						Ultimate lbs. (kN)	Allowable lbs. (kN)	Ultimate lbs. (kN)	Allowable lbs. (kN)
Threaded Rod Anchors Installed on the Face of the CMU Wall (see Figure 1)									
3/8 (9.5)	1/2	3 3/8 (86)	12 (305)	12 (305)	8 (203)	7,441 (33.1)	1,490 (6.6)	5,721 (25.4)	1,145 (5.1)
1/2 (12.7)	5/8	4 1/2 (114)	12 (305)	12 (305)	8 (203)	9,125 (40.6)	1,825 (8.1)	6,997 (31.1)	1,350 (6.0)
5/8 (15.9)	3/4	5 5/8 (143)	12 (305)	12 (305)	8 (203)	9,618 (42.8)	1,895 (8.4)	6,887 (30.6)	1,350 (6.0)
3/4 (19.1)	7/8	6 1/2 (165)	12 (305)	12 (305)	8 (203)	9,480 (42.2)	1,895 (8.4)	6,747 (30.0)	1,350 (6.0)
Rebar Anchors Installed on the Face of the CMU Wall (see Figure 1)									
#3 (9.5)	1/2	3 3/8 (86)	12 (305)	12 (305)	8 (203)	6,982 (31.1)	1,395 (6.2)	7,299 (32.5)	1,460 (6.5)
#4 (12.7)	5/8	4 1/2 (114)	12 (305)	12 (305)	8 (203)	9,167 (40.8)	1,835 (8.2)	8,144 (36.2)	1,505 (6.7)
#5 (15.9)	3/4	5 5/8 (143)	12 (305)	12 (305)	8 (203)	10,925 (48.6)	2,185 (9.7)	7,530 (33.5)	1,505 (6.7)

1. Threaded rods must comply with ASTM F1554 Grade 36, Grade C minimum. Rebar must comply with ASTM A615, Grade 60 minimum.
2. Values for 8-inch wide concrete masonry units (CMU) with a minimum specified compressive strength of masonry, f'_m , at 28 days is 1500 psi.
3. Embedment depth is measured from the outside face of the concrete masonry unit.
4. Allowable loads may be increased 33 1/3% for short-term loading due to wind forces or seismic forces where permitted by code.
5. Refer to in-service temperature sensitivity chart for allowable load adjustment for temperature.
6. The tabulated allowable loads are based on a safety factor of 5.0 for installations under the IBC and IRC.
7. Refer to allowable load-adjustment factors for end distance, edge distance and spacing on page 21.

Figure 1

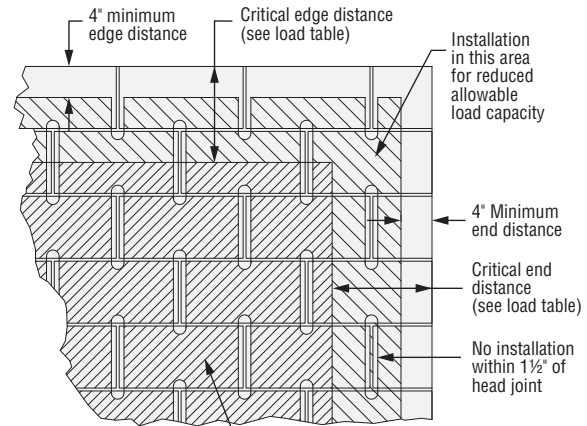

Shaded Area = Placement for Full and Reduced Allowable Load Capacity in Grout-Filled CMU

In-Service Temperature Sensitivity

Base Material Temperature		Percent Allowable Load
°F	°C	
70	21	100%
110	43	89%
125	52	89%
135	57	74%
150	66	74%

1. Refer to temperature sensitivity chart for allowable bond strength reduction for temperature. See page 225 for more information.
2. Percent allowable load may be linearly interpolated for intermediate base material temperatures.
3. °C = (°F-32) / 1.8



SET-XP® High-Strength Anchoring Adhesive for Cracked and Uncracked Concrete

Epoxy Adhesives

Load-Adjustment Factors for SET-XP® Adhesive in Face of Wall Installation in 8" Grout-Filled CMU: End / Edge Distance and Spacing, Tension and Shear Loads

How to use these charts:

1. The following tables are for reduced end and edge distance and spacing.
2. Locate the anchor size to be used for either a tension and/or shear load application.
3. Locate the embedment (E) at which the anchor is to be installed.
4. Locate the end or edge distance (C_{act}) or spacing (S_{act}) at which the anchor is to be installed.
5. The load-adjustment factor (f_c or f_s) is the intersection of the row and column.
6. Multiply the allowable load by the applicable load-adjustment factor.
7. Reduction factors for multiple edges or spacing are multiplied together.
8. Adjustment factors do not apply to allowable steel strength values.
9. Adjustment factors are to be applied to allowable tension or shear load based on CMU strength values only.

End and Edge Distance Tension (f_c)   * See page 13 for an explanation of the load table icons

Cact (in)	Dia.	3/8	1/2	5/8	3/4	#3	#4	#5
	E	3 3/8	4 1/2	5 5/8	6 1/2	3 3/8	4 1/2	5 5/8
	C _{cr}	12	12	12	12	12	12	12
	C _{min}	4	4	4	4	4	4	4
	f _{cmin}	0.91	1.00	1.00	1.00	0.96	0.88	0.88
4		0.91	1.00	1.00	1.00	0.96	0.88	0.88
6		0.93	1.00	1.00	1.00	0.97	0.91	0.91
8		0.96	1.00	1.00	1.00	0.98	0.94	0.94
10		0.98	1.00	1.00	1.00	0.99	0.97	0.97
12		1.00	1.00	1.00	1.00	1.00	1.00	1.00

See Notes Below

End and Edge Distance Shear (f_c) Shear Load Perpendicular to End or Edge   * **End and Edge Distance Shear (f_c) Shear Load Parallel to End or Edge**   *

Cact (in)	Dia.	3/8	1/2	5/8	3/4	#3	#4	#5
	E	3 3/8	4 1/2	5 5/8	6 1/2	3 3/8	4 1/2	5 5/8
	C _{cr}	12	12	12	12	12	12	12
	C _{min}	4	4	4	4	4	4	4
	f _{cmin}	0.72	0.58	0.48	0.44	0.62	0.54	0.43
4		0.72	0.58	0.48	0.44	0.62	0.54	0.43
6		0.79	0.69	0.61	0.58	0.72	0.66	0.57
8		0.86	0.79	0.74	0.72	0.81	0.77	0.72
10		0.93	0.90	0.87	0.86	0.91	0.89	0.86
12		1.00	1.00	1.00	1.00	1.00	1.00	1.00

Cact (in)	Dia.	3/8	1/2	5/8	3/4	#3	#4	#5
	E	3 3/8	4 1/2	5 5/8	6 1/2	3 3/8	4 1/2	5 5/8
	C _{cr}	12	12	12	12	12	12	12
	C _{min}	4	4	4	4	4	4	4
	f _{cmin}	0.94	0.87	0.87	0.85	0.84	0.82	0.82
4		0.94	0.87	0.87	0.85	0.84	0.82	0.82
6		0.96	0.90	0.90	0.89	0.88	0.87	0.87
8		0.97	0.94	0.94	0.93	0.92	0.91	0.91
10		0.99	0.97	0.97	0.96	0.96	0.96	0.96
12		1.00	1.00	1.00	1.00	1.00	1.00	1.00

1. E = Embedment depth (inches).
2. C_{act} = actual end or edge distance at which anchor is installed (inches).
3. C_{cr} = critical end or edge distance for 100% load (inches).
4. C_{min} = minimum end or edge distance for reduced load (inches).
5. f_c = adjustment factor for allowable load at actual end or edge distance.
6. f_{c,cr} = adjustment factor for allowable load at critical end or edge distance. f_{c,cr} is always = 1.00.
7. f_{cmin} = adjustment factor for allowable load at minimum end or edge distance.
8. $f_c = f_{cmin} + [(1 - f_{cmin}) (C_{act} - C_{min}) / (C_{cr} - C_{min})]$.

Spacing Tension (f_s)   * **Spacing Shear (f_s)**   *

Sact (in)	Dia.	3/8	1/2	5/8	3/4	#3	#4	#5
	E	3 3/8	4 1/2	5 5/8	6 1/2	3 3/8	4 1/2	5 5/8
	S _{cr}	8	8	8	8	8	8	8
	S _{min}	4	4	4	4	4	4	4
	f _{smin}	1.00	0.82	0.82	0.82	0.87	0.87	0.87
4		1.00	0.82	0.82	0.82	0.87	0.87	0.87
5		1.00	0.87	0.87	0.87	0.90	0.90	0.90
6		1.00	0.91	0.91	0.91	0.94	0.94	0.94
7		1.00	0.96	0.96	0.96	0.97	0.97	0.97
8		1.00	1.00	1.00	1.00	1.00	1.00	1.00

Sact (in)	Dia.	3/8	1/2	5/8	3/4	#3	#4	#5
	E	3 3/8	4 1/2	5 5/8	6 1/2	3 3/8	4 1/2	5 5/8
	S _{cr}	8	8	8	8	8	8	8
	S _{min}	4	4	4	4	4	4	4
	f _{smin}	1.00	1.00	1.00	1.00	0.91	0.91	1.00
4		1.00	1.00	1.00	1.00	0.91	0.91	1.00
5		1.00	1.00	1.00	1.00	0.93	0.93	1.00
6		1.00	1.00	1.00	1.00	0.96	0.96	1.00
7		1.00	1.00	1.00	1.00	0.98	0.98	1.00
8		1.00	1.00	1.00	1.00	1.00	1.00	1.00

1. E = Embedment depth (inches).
2. S_{act} = actual spacing distance at which anchors are installed (inches).
3. S_{cr} = critical spacing distance for 100% load (inches).
4. S_{min} = minimum spacing distance for reduced load (inches).
5. f_s = adjustment factor for allowable load at actual spacing distance.
6. f_{s,cr} = adjustment factor for allowable load at critical spacing distance. f_{s,cr} is always = 1.00.
7. f_{smin} = adjustment factor for allowable load at minimum spacing distance.
8. $f_s = f_{smin} + [(1 - f_{smin}) (S_{act} - S_{min}) / (S_{cr} - S_{min})]$.

SET Anchoring Adhesive

Epoxy Adhesives

SET is a two-component, 1:1 ratio, high-solids, epoxy-based adhesive for use as a high strength, non-shrink anchor grouting material. Resin and hardener are dispensed and mixed simultaneously through the mixing nozzle. SET meets or exceeds the requirements of ASTM C-881 specification for Type I, II, IV and V, Grade 3, Class B and C.

USES:

- Threaded-rod anchoring
- Rebar doweling
- Bonding hardened concrete to hardened concrete
- Pick-proof sealant around doors, windows and fixtures
- Paste-over for crack injection

CODES: ICC-ES ESR-1772 (CMU & URM); City of L.A. RR25279; Florida FL 11506.4; Caltrans approved; multiple DOT listings; NSF/ANSI Standard 61 (216 in2/1000 gal), except SET1.7KTA.

⚠ The load tables list values based upon results from the most recent testing and may not reflect those in current code reports. Where code jurisdictions apply, consult the current reports for applicable load values.

APPLICATION: Surfaces to receive epoxy must be clean. For installations in or through standing water, see page 225 for details. The base material temperature must be 40°F or above at the time of installation. For best results, material should be 70°–80°F at the time of application. Cartridges should not be immersed in water to facilitate warming. To warm cold material, the cartridges should be stored in a warm, uniformly heated area or storage container for a sufficient time to allow epoxy to warm completely. Mixed material in nozzle can harden in 5–7 minutes at a temperature of 40°F or above.

ASD DESIGN EXAMPLE: See page 231

INSTALLATION: See pages 70–71

SHELF LIFE: 24 months from date of manufacture in unopened side-by-side cartridge.

STORAGE CONDITIONS: For best results store between 45°F – 90°F. To store partially used cartridges, leave hardened nozzle in place. To re-use, attach new nozzle.

COLOR: Resin – white, hardener – black. When properly mixed SET adhesive will be a uniform light gray color.

CLEAN UP: Uncured material – Wipe up with cotton cloths. If desired scrub area with abrasive, waterbased cleaner and flush with water. If approved, solvents such as ketones (MEK, acetone, etc.), lacquer thinner or adhesive remover can be used. **DO NOT USE SOLVENTS TO CLEAN ADHESIVE FROM SKIN.** Take appropriate precautions when handling flammable solvents. Solvents may damage surfaces to which they are applied. Cured material – Chip or grind off surface.

TEST CRITERIA: Anchors installed with SET adhesive have been tested in accordance with ICC-ES's *Acceptance Criteria for Adhesive Anchors (AC58)*.

In addition, anchors installed with SET adhesive have been tested in accordance with ICC-ES's *Acceptance Criteria for Unreinforced Masonry Anchors (AC60)*.

PROPERTY	TEST METHOD	RESULTS
Consistency	ASTM C 881	Non-sag/thixotropic paste
Heat deflection	ASTM D 648	136°F (58°C)
Bond strength (moist cure)	ASTM C 882	3,218 psi (2 days) 3,366 psi (14 days)
Water absorption	ASTM D 570	0.110% (24 hours)
Compressive yield strength	ASTM D 695	5,065 psi (24 hours) 12,650 psi (7 days)
Compressive modulus	ASTM D 695	439,000 psi (7 days)
Gel Time (75°F)	ASTM C 881	30 min. – 60 gram mass 60 min – Thin film

CHEMICAL RESISTANCE: Very good to excellent against distilled water, inorganic acids and alkalis. Fair to good against organic acids and alkalis, and many organic solvents. Poor against ketones. For more detailed information, visit www.strongtie.com.



SET Cartridge Systems

Model No.	Capacity ounces (cubic inches)	Cartridge Type	Carton Quantity	Dispensing Tool(s)	Mixing ⁴ Nozzle
SET1.7KTA	1.7 (3.1)	side-by-side	12	Adaptor included for standard caulking tool	EMN1.7 (2 included)
SET22	22 (39.7)	side-by-side	10	EDT22S, EDTA22P or EDTA22CKT	EMN22i
SET56	56 (101.1)	side-by-side	6	EDTA56P	EMN22i or EMN50

1. Bulk containers also available, call Simpson Strong-Tie for details.
2. Cartridge and bulk estimation guides are available on pages 48–51.
3. Detailed information on dispensing tools, mixing nozzles and other adhesive accessories is available on pages 72–77.
4. Use only appropriate Simpson Strong-Tie mixing nozzle in accordance with Simpson Strong-Tie instructions. Modification or improper use of mixing nozzle may impair epoxy performance.

SUGGESTED SPECIFICATIONS: Anchoring adhesive shall be a two-component high-solids epoxy based system supplied in manufacturer's standard cartridge and dispensed through a static-mixing nozzle supplied by the manufacturer. Epoxy shall meet the minimum requirements of ASTM C-881 specification for Type I, II, IV, and V, Grade 3, Class B and C and must develop a minimum 12,650 psi compressive yield strength after 7 day cure. Epoxy must have a heat deflection temperature of a minimum 136°F (58°C). Adhesive shall be SET adhesive from Simpson Strong-Tie, Pleasanton, CA. Anchors shall be installed per Simpson Strong-Tie instructions for SET adhesive.

ACCESSORIES: See pages 72–77 for information on dispensing tools, mixing nozzles and other accessories.

IMPORTANT – See Pages 70–71 for Installation Instructions

SET Anchoring Adhesive

Cure Schedule

Base Material Temperature		Cure Time (hrs.)
°F	°C	
40	4	72
65	18	24
85	29	20
90	32	16

In-Service Temperature Sensitivity

Base Material Temperature		Percent Allowable Load
°F	°C	
40	4	100%
70	21	100%
110	43	100%
135	57	75%
150	66	44%
180	82	20%

1. Refer to temperature sensitivity chart for allowable bond strength reduction for temperature. See page 225 for more information.
2. Percent allowable load may be linearly interpolated for intermediate base material temperatures.
3. °C = (°F-32) / 1.8

Tension Loads for Threaded Rod Anchors in Normal-Weight Concrete
(continued on next page)



Rod Dia. in. (mm)	Drill Bit Dia. in.	Embed. Depth in. (mm)	Critical Edge Dist. in. (mm)	Critical Spacing Dist. in. (mm)	Tension Load Based on Bond Strength						Tension Load Based on Steel Strength		
					f'c ≥ 2000 psi (13.8 MPa) Concrete			f'c ≥ 4000 psi (27.6 MPa) Concrete			F1554 Grade 36	A193 GR B7	F593 304SS
					Ultimate lbs. (kN)	Std. Dev. lbs. (kN)	Allow. lbs. (kN)	Ultimate lbs. (kN)	Std. Dev. lbs. (kN)	Allow. lbs. (kN)	Allow. lbs. (kN)	Allow. lbs. (kN)	Allow. lbs. (kN)
3/8 (9.5)	1/2	1 3/4 (44)	2 5/8 (67)	7 (178)	1,900 (8.5)	485 (2.2)	475 (2.1)	1,900 (8.5)	—	475 (2.1)	2,105 (9.4)	4,535 (20.2)	3,630 (16.1)
		3 1/2 (89)	5 1/4 (133)	14 (356)	10,200 (45.4)	119 (0.5)	2,550 (11.3)	10,280 (45.7)	97 (0.4)	2,570 (11.4)			
		4 1/2 (114)	6 3/4 (171)	18 (457)	10,613 (47.2)	84 (0.4)	2,655 (11.8)	10,613 (47.2)	—	2,655 (11.8)			
1/2 (12.7)	5/8	2 1/8 (54)	3 3/16 (81)	8 1/2 (216)	7,216 (32.1)	1,163 (5.2)	1,805 (8.0)	7,216 (32.1)	—	1,805 (8.0)	3,750 (16.7)	8,080 (35.9)	6,470 (28.8)
		4 1/4 (108)	6 5/8 (162)	17 (432)	17,700 (78.7)	629 (2.8)	4,425 (19.7)	18,400 (81.8)	788 (3.5)	4,600 (20.5)			
		6 (152)	9 (229)	24 (610)	18,556 (82.5)	853 (3.8)	4,640 (20.6)	18,556 (82.5)	—	4,640 (20.6)			
5/8 (15.9)	3/4	2 1/2 (64)	3 3/4 (95)	10 (254)	6,780 (30.2)	315 (1.4)	1,695 (7.5)	6,780 (30.2)	—	1,695 (7.5)	5,875 (26.1)	12,660 (56.3)	10,120 (45.0)
		3 3/4 (95)	5 5/8 (143)	15 (381)	—	—	4,190 (18.6)	—	—	4,875 (21.7)			
		5 (127)	7 1/2 (191)	20 (508)	26,700 (118.8)	1,121 (5.0)	6,680 (29.7)	32,200 (143.2)	964 (4.3)	8,050 (35.8)			
		7 3/16 (183)	10 7/8 (276)	28 3/4 (730)	—	—	7,515 (33.4)	—	—	8,200 (36.5)			
		9 5/8 (238)	14 1/8 (359)	37 1/2 (953)	33,402 (148.6)	1,198 (5.3)	8,350 (37.1)	33,402 (148.6)	—	8,350 (37.1)			
3/4 (19.1)	7/8	3 3/8 (86)	5 1/16 (129)	13 1/2 (343)	15,456 (68.8)	2,621 (11.7)	3,865 (17.2)	15,456 (68.8)	—	3,865 (17.2)	8,460 (37.6)	18,230 (81.1)	12,400 (55.2)
		5 1/16 (129)	7 5/8 (194)	20 3/4 (514)	—	—	7,195 (32.0)	—	—	7,245 (32.2)			
		6 3/4 (171)	10 1/8 (257)	27 (686)	42,100 (187.3)	1,945 (8.7)	10,525 (46.8)	42,480 (189.0)	1,575 (7.0)	10,620 (47.2)			
		9 (229)	13 1/2 (343)	36 (914)	—	—	11,220 (49.9)	—	—	11,265 (50.1)			
		11 1/4 (286)	16 7/8 (429)	45 (1143)	47,634 (211.9)	608 (2.7)	11,910 (53.0)	47,634 (211.9)	—	11,910 (53.0)			

See Notes on Next Page



SET Anchoring Adhesive

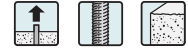

* See page 13 for an explanation of the load table icons

Tension Loads for Threaded Rod Anchors in Normal-Weight Concrete
(continued from previous page)

Epoxy Adhesives

Rod Dia. in. (mm)	Drill Bit Dia. in.	Embed. Depth in. (mm)	Critical Edge Dist. in. (mm)	Critical Spacing Dist. in. (mm)	Tension Load Based on Bond Strength						Tension Load Based on Steel Strength		
					f' _c ≥ 2000 psi (13.8 MPa) Concrete			f' _c ≥ 4000 psi (27.6 MPa) Concrete			F1554 Grade 36	A193 GR B7	F593 304SS
					Ultimate lbs. (kN)	Std. Dev. lbs. (kN)	Allow. lbs. (kN)	Ultimate lbs. (kN)	Std. Dev. lbs. (kN)	Allow. lbs. (kN)	Allow. lbs. (kN)	Allow. lbs. (kN)	Allow. lbs. (kN)
7/8 (22.2)	1	3 7/8 (98)	5 1 3/16 (148)	15 1/2 (394)	19,120 (85.1)	1,239 (5.5)	4,780 (21.3)	19,120 (85.1)	—	4,780 (21.3)	11,500 (51.2)	24,785 (110.2)	16,860 (75.0)
		5 1 3/16 (148)	8 3/4 (222)	23 1/4 (591)	—	—	8,535 (38.0)	—	—	9,250 (41.1)			
		7 3/4 (197)	11 1/8 (295)	31 (787)	49,160 (218.7)	2,149 (9.6)	12,290 (54.7)	54,880 (244.1)	1,050 (4.7)	13,720 (61.0)			
		10 7/16 (265)	15 5/8 (397)	41 3/4 (1060)	—	—	14,480 (64.4)	—	—	15,195 (67.6)			
		13 3/8 (333)	19 3/8 (498)	52 1/2 (1334)	66,679 (296.6)	506 (2.3)	16,670 (74.2)	66,679 (296.6)	—	16,670 (74.2)			
1 (25.4)	1 1/8	4 1/2 (114)	6 3/4 (171)	18 (457)	20,076 (89.3)	2,388 (10.6)	5,020 (22.3)	20,076 (89.3)	—	5,020 (22.3)	15,025 (66.8)	32,380 (144.0)	22,020 (97.9)
		6 3/4 (171)	10 1/8 (257)	27 (686)	—	—	10,020 (44.6)	—	—	10,640 (47.3)			
		9 (229)	13 1/2 (343)	36 (914)	60,060 (267.2)	5,472 (24.3)	15,015 (66.8)	65,020 (289.2)	2,924 (13.0)	16,255 (72.3)			
		12 (305)	18 (457)	48 (1219)	—	—	17,810 (79.2)	—	—	18,430 (82.0)			
		15 (381)	22 1/2 (572)	60 (1524)	82,401 (366.5)	6,432 (28.6)	20,600 (91.6)	82,401 (366.5)	—	20,600 (91.6)			
1 1/8 (28.6)	1 1/4	5 1/4 (130)	7 3/4 (197)	20 1/2 (521)	27,560 (122.6)	—	6,890 (30.6)	27,560 (122.6)	—	6,890 (30.6)	19,025 (84.6)	41,000 (182.4)	27,880 (124.0)
		7 5/8 (194)	11 1/2 (292)	30 1/2 (775)	—	—	12,105 (53.8)	—	—	12,500 (55.6)			
		10 1/8 (257)	15 1/4 (387)	40 1/2 (1029)	69,200 (307.8)	—	17,300 (77.0)	72,340 (321.8)	—	18,085 (80.4)			
		13 1/2 (343)	20 3/4 (514)	54 (1372)	—	—	21,380 (95.1)	—	—	21,770 (96.8)			
		16 3/8 (429)	25 5/8 (645)	67 1/2 (1715)	101,820 (452.9)	—	25,455 (113.2)	101,820 (452.9)	—	25,455 (113.2)			
1 1/4 (31.8)	1 3/8	5 5/8 (143)	8 7/16 (214)	22 1/2 (572)	35,858 (159.5)	2,389 (10.6)	8,965 (39.9)	35,858 (159.5)	—	8,965 (39.9)	23,490 (104.5)	50,620 (225.2)	34,425 (153.1)
		8 7/16 (214)	12 3/4 (324)	33 3/4 (857)	—	—	14,115 (62.8)	—	—	14,115 (62.8)			
		11 1/4 (286)	16 3/8 (429)	45 (1143)	77,045 (342.7)	7,024 (31.2)	19,260 (85.7)	77,045 (342.7)	—	19,260 (85.7)			
		15 (381)	22 1/2 (572)	60 (1524)	—	—	24,965 (111.0)	—	—	24,965 (111.0)			
		18 3/4 (476)	28 1/8 (714)	75 (1905)	122,681 (545.7)	10,940 (48.7)	30,670 (136.4)	122,681 (545.7)	—	30,670 (136.4)			

1. Allowable load must be the lesser of the bond or steel strength.
2. The allowable loads listed under allowable bond are based on a safety factor of 4.0.
3. Refer to allowable load-adjustment factors for spacing and edge distance on pages 31 and 33.
4. Refer to in-service temperature sensitivity chart for allowable load adjustment for temperature.
5. Anchors are permitted to be used within fire-resistive construction, provided the anchors resist wind or seismic loads only. For use in fire-resistive construction, the anchors can also be permitted to be used to resist gravity loads, provided special consideration has been given to fire-exposure conditions.
6. Anchors are not permitted to resist tension forces in overhead or wall installations unless proper consideration is given to fire-exposure and elevated-temperature conditions.
7. Allowable load based on bond strength may be interpolated for concrete compressive strengths between 2000 psi and 4000 psi.

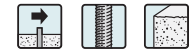

* See page 13 for an explanation of the load table icons

Epoxy Adhesives

Shear Loads for Threaded Rod Anchors in Normal-Weight Concrete

Rod Dia. in. (mm)	Drill Bit Dia. in.	Embed. Depth in. (mm)	Critical Edge Dist. in. (mm)	Critical Spacing Dist. in. (mm)	Shear Load Based on Concrete Edge Distance			Shear Load Based on Steel Strength		
					f' _c ≥ 2000 psi (13.8 MPa) Concrete			F1554 Grade 36	A193 GR B7	F593 304SS
					Ultimate lbs. (kN)	Std. Dev. lbs. (kN)	Allowable lbs. (kN)	Allowable lbs. (kN)	Allowable lbs. (kN)	Allowable lbs. (kN)
3/8 (9.5)	1/2	1 3/4 (44)	5 1/4 (133)	2 5/8 (67)	4,573 (20.3)	317 (1.4)	1,145 (5.1)	1,085 (4.8)	2,340 (10.4)	1,870 (8.3)
		3 1/2 (89)		5 1/4 (133)	6,935 (30.8)	965 (4.3)	1,735 (7.7)			
		4 1/2 (114)		5 1/4 (133)	—	—	1,735 (7.7)			
1/2 (12.7)	5/8	2 1/8 (54)	6 5/8 (162)	3 3/4 (83)	7,001 (31.1)	437 (1.9)	1,750 (7.8)	1,930 (8.6)	4,160 (18.5)	3,330 (14.8)
		4 1/4 (108)		6 5/8 (162)	11,116 (49.4)	1,696 (7.5)	2,780 (12.4)			
		6 (152)		6 5/8 (162)	—	—	2,780 (12.4)			
5/8 (15.9)	3/4	2 1/2 (64)	7 1/2 (191)	3 3/4 (95)	14,427 (64.2)	826 (3.7)	3,605 (16.0)	3,025 (13.5)	6,520 (29.0)	5,220 (23.2)
		5 (127)		7 1/2 (191)	19,501 (86.7)	1,027 (4.6)	4,875 (21.7)			
		9 3/8 (238)		7 1/2 (191)	—	—	4,875 (21.7)			
3/4 (19.1)	7/8	3 3/8 (86)	10 1/8 (257)	5 1/8 (130)	21,180 (94.2)	942 (4.2)	5,295 (23.6)	4,360 (19.4)	9,390 (41.8)	6,385 (28.4)
		6 3/4 (171)		10 1/8 (257)	25,244 (112.3)	2,538 (11.3)	6,310 (28.1)			
		11 1/4 (286)		10 1/8 (257)	—	—	6,310 (28.1)			
7/8 (22.2)	1	3 7/8 (98)	11 1/8 (295)	5 7/8 (149)	28,333 (126.0)	2,406 (10.7)	7,085 (31.5)	5,925 (26.4)	12,770 (56.8)	8,685 (38.6)
		7 3/4 (197)		11 1/8 (295)	33,533 (149.2)	2,793 (12.4)	8,385 (37.3)			
		13 3/8 (333)		11 1/8 (295)	—	—	8,385 (37.3)			
1 (25.4)	1 1/8	4 1/2 (114)	13 1/2 (343)	6 3/4 (171)	30,520 (135.8)	2,166 (9.6)	7,630 (33.9)	7,740 (34.4)	16,680 (74.2)	11,345 (50.5)
		9 (229)		13 1/2 (343)	50,187 (223.2)	2,176 (9.7)	12,545 (55.8)			
		15 (381)		13 1/2 (343)	—	—	12,545 (55.8)			
1 1/8 (28.6)	1 1/4	5 1/8 (130)	15 1/4 (387)	7 3/4 (197)	41,325 (183.8)	—	10,330 (46.0)	9,800 (43.6)	21,125 (94.0)	14,365 (63.9)
		10 1/8 (257)		15 1/4 (387)	58,285 (259.3)	—	14,570 (64.8)			
		16 7/8 (429)		15 1/4 (387)	—	—	14,570 (64.8)			
1 1/4 (31.8)	1 3/8	5 3/8 (143)	16 3/8 (429)	8 1/2 (216)	52,130 (231.9)	3,969 (17.7)	13,035 (58.0)	12,100 (53.8)	26,075 (116.0)	17,730 (78.9)
		11 1/4 (286)		16 3/8 (429)	66,383 (295.3)	3,948 (17.6)	16,595 (73.8)			
		18 3/4 (476)		16 3/8 (429)	—	—	16,595 (73.8)			

1. Allowable load must be the lesser of the load based on concrete edge distance or steel strength.
2. The allowable loads based on concrete edge distance are based on a safety factor of 4.0.
3. Refer to allowable load-adjustment factors for spacing and edge distance on pages 32 and 34.
4. Refer to in-service temperature sensitivity chart for allowable load adjustment for temperature.
5. Anchors are permitted to be used within fire-resistive construction, provided the anchors resist wind or seismic loads only. For use in fire-resistive construction, the anchors can also be permitted to be used to resist gravity loads, provided special consideration has been given to fire-exposure conditions.

SET Anchoing Adhesive

Epoxy Adhesives

Tension Loads for Threaded Rod Anchors in Normal-Weight Concrete Stemwall

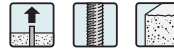

* See page 13 for an explanation of the load table icons

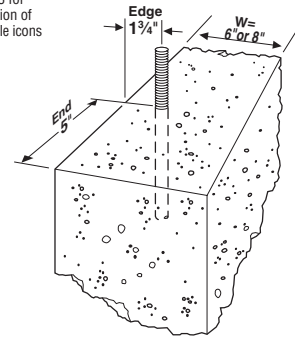

Edge and end distances for threaded rod in concrete foundation stemwall corner installation

Rod Dia. in. (mm)	Drill Bit Dia. in.	Embed. Depth in. (mm)	Stemwall Width in. (mm)	Min. Edge Dist. in. (mm)	Min. End Dist. in. (mm)	Tension Load Based on Bond Strength		Tension Load Based on Steel Strength
						$f'_c \geq 2500$ psi (17.2 MPa) Concrete		F1554 Grade 36
						Ultimate lbs. (kN)	Allowable lbs. (kN)	Allowable lbs. (kN)
$\frac{5}{8}$ (15.9)	$\frac{3}{4}$	10 (254.0)	6 (152.4)	$1\frac{1}{4}$ (44.5)	5 (127.0)	13,634 (60.6)	3,410 (15.2)	5,875 (26.1)
$\frac{7}{8}$ (22.2)	1	15 (381.0)	8 (203.2)	$1\frac{1}{4}$ (44.5)	5 (127.0)	22,664 (100.8)	5,665 (25.2)	11,500 (51.2)

1. Allowable load must be the lesser of the bond or steel strength.
2. The allowable loads listed under allowable bond are based on a safety factor of 4.0.
3. Refer to in-service temperature sensitivity chart for allowable load adjustment for temperature.
4. Anchors are permitted to be used within fire-resistive construction, provided the anchors resist wind or seismic loads only. For use in fire-resistive construction, the anchors can also be permitted to be used to resist gravity loads, provided special consideration has been given to fire-exposure conditions.

Shear Loads for Threaded Rod Anchors in Normal-Weight Concrete, Load Applied Parallel to Concrete Edge

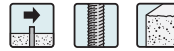

* See page 13 for an explanation of the load table icons

Rod Dia. in. (mm)	Drill Bit Dia. in.	Embed. Depth in. (mm)	Min. Edge Dist. in. (mm)	Min. End Dist. in. (mm)	Shear Load Based on Concrete Edge Distance			Shear Load Based on Steel Strength
					$f'_c \geq 2000$ psi (13.8 MPa) Concrete			F1554 Grade 36
					Ultimate lbs. (kN)	Std. Dev. lbs. (kN)	Allowable lbs. (kN)	Allowable lbs. (kN)
$\frac{1}{2}$ (12.7)	$\frac{5}{8}$	$4\frac{1}{4}$ (108.0)	$1\frac{1}{4}$ (44.5)	$8\frac{1}{2}$ (219.9)	8,496 (37.8)	654 (2.9)	2,125 (9.5)	1,930 (8.6)
$\frac{5}{8}$ (15.9)	$\frac{3}{4}$	5 (127.0)	$1\frac{1}{4}$ (44.5)	10 (254.0)	8,857 (39.4)	225 (1.0)	2,215 (9.9)	3,025 (13.5)

1. Allowable load must be the lesser of the load based on concrete edge distance, steel strength or wood bearing capacity.
2. The allowable loads based on concrete edge distance are based on a safety factor of 4.0.
3. Refer to allowable load-adjustment factors for spacing on page 34.
4. Refer to in-service temperature sensitivity chart for allowable load adjustment for temperature.
5. Anchors are permitted to be used within fire-resistive construction, provided the anchors resist wind or seismic loads only. For use in fire-resistive construction, the anchors can also be permitted to be used to resist gravity loads, provided special consideration has been given to fire-exposure conditions.

SET® Anchoring Adhesive

Tension Loads for Rebar Dowels in Normal-Weight Concrete

Rebar Size No. (mm)	Drill Bit Dia. in.	Embed. Depth in. (mm)	Critical Edge Dist. in. (mm)	Critical Spacing Dist. in. (mm)	Tension Load Based on Bond Strength						Tension Load Based on Steel Strength
					f' _c ≥ 2000 psi (13.8 MPa) Concrete			f' _c ≥ 4000 psi (27.6 MPa) Concrete			ASTM A615 Grade 60 Rebar
					Ultimate lbs. (kN)	Std. Dev. lbs. (kN)	Allow. lbs. (kN)	Ultimate lbs. (kN)	Std. Dev. lbs. (kN)	Allow. lbs. (kN)	Allowable lbs. (kN)
#4 (12.7)	5/8	4 1/4 (108)	6 3/8 (162)	17 (432)	16,480 (73.3)	245 (1.1)	4,120 (18.3)	18,320 (81.5)	560 (2.5)	4,580 (20.4)	4,800 (21.4)
		6 (152)	9 (229)	24 (610)	19,360 (86.1)	678 (3.0)	4,840 (21.5)	19,360 (86.1)	—	4,840 (21.5)	
#5 (15.9)	3/4	5 (127)	7 1/2 (191)	20 (508)	24,600 (109.4)	2,598 (11.6)	6,150 (27.4)	26,040 (115.8)	1,740 (7.7)	6,510 (29.0)	7,440 (33.1)
		9 3/8 (238)	14 1/8 (359)	37 1/2 (953)	48,380 (215.2)	2,841 (12.6)	12,095 (53.8)	48,380 (215.2)	—	12,095 (53.8)	
#6 (19.1)	7/8	6 3/4 (171)	10 1/8 (257)	27 (686)	38,380 (170.7)	4,044 (18.0)	9,595 (42.7)	40,500 (180.2)	1,533 (6.8)	10,125 (45.0)	10,560 (47.0)
		11 1/4 (286)	16 3/8 (429)	45 (1143)	65,020 (289.2)	3,152 (14.0)	16,255 (72.3)	65,020 (289.2)	—	16,255 (72.3)	
#7 (22.2)	1	7 3/4 (197)	11 5/8 (295)	31 (787)	47,760 (212.4)	1,266 (5.6)	11,940 (53.1)	47,760 (212.4)	—	11,940 (53.1)	14,400 (64.1)
		13 1/8 (333)	19 3/8 (498)	52 1/2 (1334)	81,560 (362.8)	3,575 (15.9)	20,390 (90.7)	81,560 (362.8)	—	20,390 (90.7)	
#8 (25.4)	1 1/8	9 (229)	13 1/2 (343)	36 (914)	53,680 (238.8)	—	13,420 (59.7)	53,680 (238.8)	—	13,420 (59.7)	18,960 (84.3)
		15 (381)	22 1/2 (572)	60 (1524)	94,240 (419.2)	7,520 (33.5)	23,560 (104.8)	94,240 (419.2)	—	23,560 (104.8)	
#9 (28.6)	1 1/4	10 1/8 (257)	15 1/4 (387)	40 1/2 (1029)	53,680 (238.8)	7,977 (35.5)	13,420 (59.7)	53,680 (238.8)	—	13,420 (59.7)	24,000 (106.8)
		16 3/8 (429)	25 3/8 (645)	67 1/2 (1715)	111,460 (495.8)	5,753 (25.6)	27,865 (123.9)	111,460 (495.8)	—	27,865 (123.9)	
#10 (31.8)	1 1/2	11 1/4 (286)	16 3/8 (429)	45 (1143)	76,000 (338.1)	1,408 (6.3)	19,000 (84.5)	76,000 (338.1)	—	19,000 (84.5)	30,480 (135.6)
		18 3/4 (476)	28 (711)	75 (1905)	125,840 (559.8)	9,551 (42.5)	31,460 (139.9)	125,840 (559.8)	—	31,460 (139.9)	
#11 (34.9)	1 5/8	12 3/8 (314)	18 3/8 (473)	49 1/2 (1257)	87,500 (389.2)	3,498 (15.6)	21,875 (97.3)	87,500 (389.2)	—	21,875 (97.3)	37,440 (166.5)
		20 3/8 (524)	28 (711)	82 1/2 (2096)	132,080 (587.5)	11,297 (50.3)	33,020 (146.9)	132,080 (587.5)	—	33,020 (146.9)	

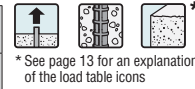

* See page 13 for an explanation of the load table icons

1. Allowable load must be the lesser of the bond or steel strength.
2. The allowable loads listed under allowable bond are based on a safety factor of 4.0.
3. Refer to allowable load-adjustment factors for spacing and edge distance on pages 31 and 33.
4. Refer to in-service temperature sensitivity chart for allowable load adjustment for temperature.
5. Anchors are permitted to be used within fire-resistive construction, provided the anchors resist wind or seismic loads only. For use in fire-resistive construction, the anchors can also be permitted to be used to resist gravity loads, provided special consideration has been given to fire-exposure conditions.
6. Anchors are not permitted to resist tension forces in overhead or wall installations unless proper consideration is given to fire exposure and elevated-temperature conditions.
7. Allowable load based on bond strength may be interpolated for concrete compressive strengths between 2000 psi and 4000 psi.

Epoxy Adhesives

Shear Loads for Rebar Dowels in Normal-Weight Concrete

Rebar Size No. (mm)	Drill Bit Dia. in.	Embed. Depth in. (mm)	Critical Edge Dist. in. (mm)	Critical Spacing Dist. in. (mm)	Shear Load Based on Concrete Edge Distance			Shear Load Based on Steel Strength
					f' _c ≥ 2000 psi (13.8 MPa) Concrete			ASTM A615 Grade 60 Rebar
					Ultimate lbs. (kN)	Std. Dev. lbs. (kN)	Allow. lbs. (kN)	Allowable lbs. (kN)
#4 (12.7)	5/8	4 1/4 (108)	6 3/8 (162)	6 3/8 (162)	15,156 (67.4)	542 (2.4)	3,790 (16.9)	3,060 (13.6)
		6 (152)	—	—	15,156 (67.4)	—	3,790 (16.9)	
#5 (15.9)	3/4	5 (127)	7 1/2 (191)	7 1/2 (191)	24,245 (107.8)	1,121 (5.0)	6,060 (27.0)	4,740 (21.1)
		9 3/8 (238)	—	—	24,245 (107.8)	—	6,060 (27.0)	
#6 (19.1)	7/8	6 3/4 (171)	10 1/8 (257)	10 1/8 (257)	33,195 (147.7)	2,314 (10.3)	8,300 (36.9)	6,730 (29.9)
		11 1/4 (286)	—	—	33,195 (147.7)	—	8,300 (36.9)	
#7 (22.2)	1	7 3/4 (197)	11 5/8 (295)	11 5/8 (295)	47,017 (209.1)	2,227 (9.9)	11,755 (52.3)	9,180 (40.8)
		13 1/8 (333)	—	—	47,017 (209.1)	—	11,755 (52.3)	
#8 (25.4)	1 1/8	9 (229)	13 1/2 (343)	13 1/2 (343)	58,880 (261.9)	—	14,720 (65.5)	12,085 (53.8)
		15 (381)	—	—	58,880 (261.9)	—	14,720 (65.5)	
#9 (28.6)	1 1/4	10 1/8 (257)	15 1/4 (387)	15 1/4 (387)	58,880 (261.9)	1,487 (6.6)	14,720 (65.5)	15,300 (68.1)
		16 3/8 (429)	—	—	58,880 (261.9)	—	14,720 (65.5)	
#10 (31.8)	1 1/2	11 1/4 (286)	16 3/8 (429)	16 3/8 (429)	65,840 (292.9)	7,120 (31.7)	16,460 (73.2)	19,430 (86.4)
		18 3/4 (476)	—	—	65,840 (292.9)	—	16,460 (73.2)	
#11 (34.9)	1 5/8	12 3/8 (314)	18 3/8 (473)	18 3/8 (473)	81,400 (362.1)	9,596 (42.7)	20,350 (90.5)	23,870 (106.2)
		20 3/8 (524)	—	—	81,400 (362.1)	—	20,350 (90.5)	

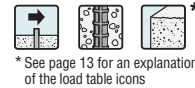

* See page 13 for an explanation of the load table icons

1. Allowable load must be the lesser of the load based on concrete edge distance or steel strength.
2. The allowable loads based on concrete edge distance are based on a safety factor of 4.0.
3. Refer to allowable load-adjustment factors for spacing and edge distance on pages 32 and 34.
4. Refer to in-service temperature Sensitivity chart for allowable load adjustment for temperature.
5. Anchors are permitted to be used within fire-resistive construction, provided the anchors resist wind or seismic loads only. For use in fire-resistive construction, the anchors can also be permitted to be used to resist gravity loads, provided special consideration has been given to fire-exposure conditions.



* See page 13 for an explanation of the load table icons

Tension Loads for Threaded Rod Anchors in Sand-Lightweight Concrete

Rod Dia. in. (mm)	Drill Bit Dia. in.	Embed. Depth in. (mm)	Critical Edge Dist. in. (mm)	Critical Spacing Dist. in. (mm)	Tension Load Based on Bond Strength			Tension Load Based on Steel Strength		
					f' _c ≥ 3000 psi (20.7 MPa) Lightweight Concrete			F1554 Grade 36	A193 GR B7	F593 304SS
					Ultimate lbs. (kN)	Std. Dev. lbs. (kN)	Allowable lbs. (kN)	Allowable lbs. (kN)	Allowable lbs. (kN)	Allowable lbs. (kN)
3/8 (9.5)	1/2	1 3/4 (44)	2 5/8 (67)	3 1/2 (89)	2,400 (10.7)	540 (2.4)	600 (2.7)	2,105 (9.4)	4,535 (20.2)	3,630 (16.1)
		3 1/2 (89)	5 1/4 (133)	7 (178)	6,220 (27.7)	422 (1.9)	1,555 (6.9)			
1/2 (12.7)	5/8	2 1/8 (54)	3 1/8 (79)	4 1/4 (108)	2,900 (12.9)	550 (2.4)	725 (3.2)	3,750 (16.7)	8,080 (35.9)	6,470 (28.8)
		4 1/4 (108)	6 3/8 (162)	8 1/2 (216)	6,720 (29.9)	1,087 (4.8)	1,680 (7.5)			
5/8 (15.9)	3/4	2 1/2 (64)	3 3/4 (95)	5 (127)	4,820 (21.4)	327 (1.5)	1,205 (5.4)	5,875 (26.1)	12,660 (56.3)	10,120 (45.0)
		5 (127)	7 1/2 (191)	10 (254)	9,160 (40.7)	1,677 (7.5)	2,290 (10.2)			

1. Allowable load must be the lesser of the bond or steel strength.
2. The allowable loads listed under allowable bond are based on a safety factor of 4.0.
3. 100% of the allowable load is permitted at critical spacing. No reduction in spacing is allowed.
4. Refer to allowable load-adjustment factors for edge distance on page 35.
5. Refer to in-service temperature sensitivity chart for allowable load adjustment for temperature.
6. Anchors are permitted to be used within fire-resistive construction, provided the anchors resist wind or seismic loads only. For use in fire-resistive construction, the anchors can also be permitted to be used to resist gravity loads, provided special consideration has been given to fire-exposure conditions.
7. Anchors are not permitted to resist tension forces in overhead or wall installations unless proper consideration is given to fire-exposure and elevated-temperature conditions.

Shear Loads for Threaded Rod Anchors in Sand-Lightweight Concrete



* See page 13 for an explanation of the load table icons

Rod Dia. in. (mm)	Drill Bit Dia. in.	Embed. Depth in. (mm)	Critical Edge Dist. in. (mm)	Critical Spacing Dist. in. (mm)	Shear Load Based on Concrete Edge Distance			Shear Load Based on Steel Strength		
					f' _c ≥ 3000 psi (20.7 MPa) Lightweight Concrete			F1554 Grade 36	A193 GR B7	F593 304SS
					Ultimate lbs. (kN)	Std. Dev. lbs. (kN)	Allowable lbs. (kN)	Allowable lbs. (kN)	Allowable lbs. (kN)	Allowable lbs. (kN)
3/8 (9.5)	1/2	1 3/4 (44)	2 5/8 (67)	3 1/2 (89)	2,364 (10.5)	129 (0.6)	590 (2.6)	1,085 (4.8)	2,340 (10.4)	1,870 (8.3)
		3 1/2 (89)	5 1/4 (133)	7 (178)	5,784 (25.7)	547 (2.4)	1,445 (6.4)			
1/2 (12.7)	5/8	2 1/8 (54)	3 1/8 (79)	4 1/4 (108)	2,948 (13.1)	224 (1.0)	735 (3.3)	1,930 (8.6)	4,160 (18.5)	3,330 (14.8)
		4 1/4 (108)	6 3/8 (162)	8 1/2 (216)	8,436 (37.5)	891 (4.0)	2,110 (9.4)			
5/8 (15.9)	3/4	2 1/2 (64)	3 3/4 (95)	5 (127)	3,584 (15.9)	1,072 (4.8)	895 (4.0)	3,025 (13.5)	6,520 (29.0)	5,220 (23.2)
		5 (127)	7 1/2 (191)	10 (254)	11,784 (52.4)	650 (2.9)	2,945 (13.1)			

1. Allowable load must be the lesser of the load based on concrete edge distance or steel strength.
2. The allowable loads based on concrete edge distance are based on a safety factor of 4.0.
3. 100% of the allowable load is permitted at critical spacing. No reduction in spacing is allowed.
4. Refer to allowable load-adjustment factors for edge distance on page 35.
5. Refer to in-service temperature sensitivity chart for allowable load adjustment for temperature.
6. Anchors are permitted to be used within fire-resistive construction, provided the anchors resist wind or seismic loads only. For use in fire-resistive construction, the anchors can also be permitted to be used to resist gravity loads, provided special consideration has been given to fire-exposure conditions.

SET® Anchoring Adhesive

Tension and Shear Loads for Threaded Rod Anchors in 8-inch Lightweight, Medium-Weight and Normal-Weight Grout-Filled CMU

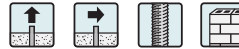

* See page 13 for an explanation of the load table icons

Rod Dia. in. (mm)	Drill Bit Dia. in.	Min. Embed. Depth in. (mm)	Critical Edge Dist. in. (mm)	Critical End Dist. in. (mm)	Critical Spacing Dist. in. (mm)	8-inch Grout-Filled CMU Allowable Loads Based on CMU Strength			
						Tension		Shear	
						Ultimate lbs. (kN)	Allowable lbs. (kN)	Ultimate lbs. (kN)	Allowable lbs. (kN)
Anchor Installed Anywhere on the Face of the CMU Wall (See Figure 1)									
1/2 (12.7)	5/8	4 1/4 (108)	17 (432)	17 (432)	17 (432)	6,496 (28.9)	1,300 (5.8)	6,766 (30.1)	1,355 (6.0)
5/8 (15.9)	3/4	5 (127)	20 (508)	20 (508)	20 (508)	8,232 (36.6)	1,645 (7.3)	13,676 (60.8)	2,735 (12.2)
3/4 (19.1)	7/8	6 1/4 (171)	27 (686)	27 (686)	27 (686)	15,656 (69.6)	3,130 (13.9)	17,578 (78.2)	3,515 (15.6)

1. Threaded rods must comply with ASTM F1554 Grade 36 minimum.
2. Values for 8-inch wide concrete masonry units (CMU) with a minimum specified compressive strength of masonry, f'_m , at 28 days is 1500 psi.
3. Embedment depth is measured from the outside face of the concrete masonry unit.
4. Allowable loads may be increased 33 1/3% for short-term loading due to wind forces or seismic forces where permitted by code.
5. Refer to in-service temperature sensitivity chart for allowable load adjustment for temperature.
6. The tabulated allowable loads are based on a safety factor of 5.0 for installations under the IBC and IRC.
7. Refer to allowable load-adjustment factors for end distance, edge distance and spacing on page 36.

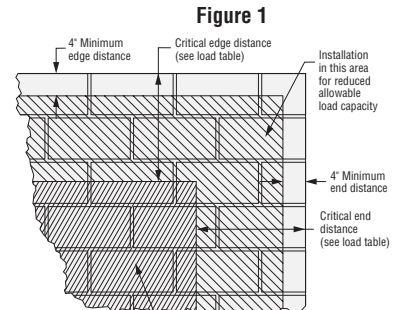

Figure 1
Shaded Area = Placement for Full and Reduced Allowable Load Capacity in Grout-Filled CMU

Tension and Shear Loads for Threaded Rod Anchors in 6 and 8-inch Lightweight, Medium-Weight and Normal-Weight Grout-Filled CMU Anchor Installed in Cell Opening (Top of Wall) See Figure 2



* See page 13 for an explanation of the load table icons

Rod Dia. in. (mm)	Drill Bit Dia. in.	Embed. Depth in. (mm)	Min. Edge Dist. in. (mm)	Min. End Dist. in. (mm)	Min. Spacing Dist. in. (mm)	6 and 8-inch Grout-Filled CMU Allowable Loads Based on CMU Strength			
						Tension		Shear	
						Ultimate lbs. (kN)	Allowable lbs. (kN)	Ultimate lbs. (kN)	Allowable lbs. (kN)
Allowable Tension and Shear Values EXCLUDING Earthquake Loads¹									
5/8 (15.9)	3/4	5 (127)	3 (76)	3 1/2 (89)	20 (508)	12,573 (55.9)	2,515 (11.2)	9,530 (42.4)	1,905 (8.5)
3/4 (19.1)	7/8	5 (127)	3 (76)	3 1/2 (89)	20 (508)	—	2,515 (11.2)	—	1,905 (8.5)
7/8 (22.2)	1	12 (305)	2 (51)	3 3/8 (98)	48 (1219)	8,908 (39.6)	1,780 (7.9)	—	—
Allowable Tension and Shear Values INCLUDING Earthquake Loads²									
5/8 (15.9)	3/4	5 (127)	3 (76)	3 1/2 (89)	20 (508)	6,500 (28.9)	1,300 (5.8)	6,780 (30.2)	1,355 (6.0)
3/4 (19.1)	7/8	5 (127)	3 (76)	3 1/2 (89)	20 (508)	—	1,300 (5.8)	—	1,355 (6.0)

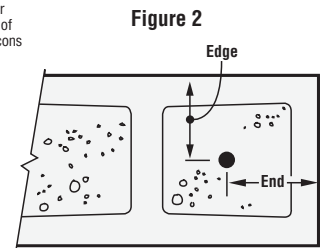

Figure 2
Anchor installed in cell opening (top of wall)

1. Allowable Tension and Shear Values EXCLUDING Earthquake Loads may not be increased for wind forces.
2. Allowable Tension and Shear Values INCLUDING Earthquake Loads may be increased 33 1/3% for wind forces or seismic forces where permitted by code.
3. Also see notes 1–3 and 5–7 below.

Tension and Shear Loads for Threaded Rod Anchors in Lightweight, Medium-Weight and Normal-Weight Hollow CMU



* See page 13 for an explanation of the load table icons

Rod Dia. in. (mm)	Drill Bit Dia. in.	Embed. Depth in. (mm)	Min. Edge Dist. in. (mm)	Min. End Dist. in. (mm)	6 and 8-inch Hollow CMU Allowable Loads Based on CMU Strength			
					Tension		Shear	
					Ultimate lbs. (kN)	Allowable lbs. (kN)	Ultimate lbs. (kN)	Allowable lbs. (kN)
Anchor Installed in Face Shell w/Simpson Strong-Tie® Epoxy Carbon-Steel Screen Tube								
5/8 (15.9)	7/8	3 1/2 (88.9)	4 (101.6)	4 3/8 (117.5)	881 (3.9)	175 (0.8)	1,440 (6.4)	290 (1.3)
3/4 (19.1)	1	3 1/2 (88.9)	4 (101.6)	4 3/8 (117.5)	—	175 (0.8)	—	290 (1.3)

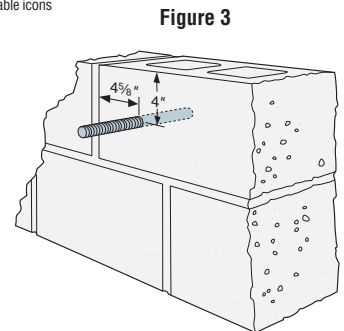

Figure 3
Anchor installed in face shell w/screen tube in hollow cell

1. Threaded rods must comply with ASTM F1554 Grade 36 minimum.
2. Values for 8-inch wide concrete masonry units (CMU) with a minimum specified compressive strength of masonry, f'_m , at 28 days is 1500 psi.
3. Embedment depth is measured from the outside face of the concrete masonry unit for installations through a face shell.
4. Allowable loads may not be increased for short-term loading due to wind forces or seismic forces.
5. Refer to in-service temperature sensitivity chart for allowable load adjustment for temperature.
6. The tabulated allowable loads are based on a safety factor of 5.0 for installations under the IBC and IRC.
7. Anchors must be spaced a minimum distance of four times the anchor embedment.
8. Screen tubes not for use with SET1.7KTA.
9. Set drill to rotation-only mode when drilling into hollow CMU.

SET® Anchoring Adhesive

Epoxy Adhesives

Tension and Shear Loads for Installations in Unreinforced Brick Masonry Walls Minimum URM Wall Thickness is 13" (3 wythes thick) *See page 13 for an explanation of the load table icons

Rod/Rebar Dia./Size in. (mm)	Drill Bit Dia. in.	Embed. Depth in. (mm)	Min. Edge/End Dist. in. (mm)	Min. Vertical Spacing Dist. in. (mm)	Min. Horiz. Spacing Dist. in. (mm)	Tension Load Based on URM Strength		Shear Load Based on URM Strength	
						Minimum Net Mortar Strength = 50 psi		Minimum Net Mortar Strength = 50 psi	
						Allowable lbs. (kN)		Allowable lbs. (kN)	
Configuration A (Simpson Strong-Tie® ETS or ETSP Screen Tube Required)									
3/4 (19.1)	1	8 (203)	16 (406)	16 (406)	16 (406)	—	—	1,000 (4.4)	—
#5 (15.9)	1	8 (203)	16 (406)	16 (406)	16 (406)	—	—	750 (3.3)	—
#6 (19.1)	1	8 (203)	16 (406)	16 (406)	16 (406)	—	—	1,000 (4.4)	—
Configuration B (Simpson Strong-Tie ETS or ETSP Screen Tube Required)									
3/4 (19.1)	1	13 (330)	16 (406)	16 (406)	16 (406)	1,200 (5.3)	—	1,000 (4.4)	—
Configuration C (Simpson Strong-Tie ETS Screen Tube and AST Steel Sleeve Required)									
5/8 (15.9)	1	**	16 (406)	16 (406)	16 (406)	1,200 (5.3)	—	750 (3.3)	—

1. Threaded rods must comply with ASTM F1554 Grade 36 minimum.
2. All holes are drilled with a 1" diameter carbide-tipped drill bit with the drill set in the rotation-only mode.
3. The unreinforced brick walls must have a minimum thickness of 13 inches (three wythes of brick).
4. The allowable load is applicable only where in-place shear tests indicate minimum net mortar strength of 50 psi.
5. The allowable load for Configuration B and C anchors subjected to a combined tension and shear load is determined by assuming a straight-line relationship between allowable tension and shear.
6. The anchors installed in unreinforced brick walls are limited to resisting seismic or wind forces only.
7. Configuration A has a straight threaded rod or rebar embedded 8 inches into the wall with a 3/4" diameter by 8-inch long screen tube (part # ETS758 or ETS758P). This configuration is designed to resist shear loads only.
8. Configuration B has a 3/4" threaded rod bent and installed at a 22.5-degree angle and installed 13 inches into the wall, to within 1-inch (maximum) of the exterior wall surface. This configuration is designed to resist tension and shear loads. The pre-bent threaded rod is installed with a 3/4" diameter by 13-inch long screen tube (part # ETS7513 or ETS7513P).
9. Configuration C is designed to resist tension and shear forces. It consists of a 5/8" diameter, ASTM F1554 Grade 36 threaded rod and an 8" long sleeve (part # AST800) and a 3/4" diameter by 8-inch long screen tube (part # ETS758). The steel sleeve has a plastic plug in one end. A 6" by 6" by 5/8" thick ASTM A 36 steel plate is located on the back face of the wall.
10. Special inspection requirements are determined by local jurisdiction and must be confirmed by the local building official.
11. Refer to in-service temperature sensitivity chart for allowable load adjustment for temperature.
12. Screen tubes not for use with SET1.7KTA.

Configuration A (Shear)

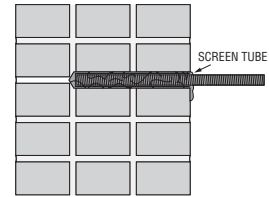

Configuration B (Tension & Shear)

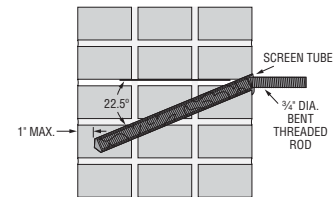

Configuration C (Tension & Shear)

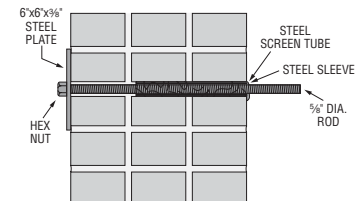

Tension and Shear Loads for Threaded Rod Anchors in Lightweight, Medium-Weight and Normal-Weight Hollow CMU *See page 13 for an explanation of the load table icons

Rod Dia. in. (mm)	Drill Bit Dia. in.	Embed. Depth in. (mm)	Critical Edge Dist. in. (mm)	Critical Spacing Dist. in. (mm)	8-inch Hollow CMU Allowable Loads Based on CMU Strength			
					Tension		Shear	
					Ultimate lbs. (kN)	Allowable lbs. (kN)	Ultimate lbs. (kN)	Allowable lbs. (kN)
Anchor Installed in Face Shell w/Simpson Strong-Tie ETSP (Plastic) Screen Tube								
3/8 (9.5)	9/16	3 (76.2)	12 (305)	8 (203)	1,500 (6.7)	300 (1.3)	1,280 (5.7)	255 (1.1)
1/2 (12.7)	3/4	3 (76.2)	12 (305)	8 (203)	1,500 (6.7)	300 (1.3)	1,280 (5.7)	255 (1.1)
5/8 (15.9)	7/8	3 (76.2)	12 (305)	8 (203)	1,500 (6.7)	300 (1.3)	1,380 (6.1)	275 (1.2)

1. Threaded rods must comply with ASTM F1554 Grade 36 minimum.
2. The tabulated allowable loads are based on a safety factor of 5.0 for installations under the IBC and IRC.
3. Edge distances may be reduced to 4" with a corresponding 32% reduction in tension capacity. Shear capacity is unaffected.
4. Values for 8-inch wide, lightweight, medium-weight and normal-weight concrete masonry units with min. compressive strength of 1,900 psi and 1 1/4" thick face shell.
5. Embedment depth is measured from the outside face of the concrete masonry unit.
6. Refer to in-service temperature sensitivity chart for allowable load adjustment for temperature.
7. Allowable loads may not be increased for short-term loading due to wind or seismic forces. Wall design must satisfy applicable design standards and be capable of withstanding applied loads.
8. Screen tubes not for use with SET1.7KTA.
9. Set drill to rotation-only mode when drilling into hollow CMU.

Installation Instructions for Configuration C:

1. Drill hole perpendicular to the wall to a depth of 8" with a 1" diameter carbide-tipped drill bit (rotation only mode).
2. Clean hole with oil-free compressed air and a nylon brush.
3. Fill 8" steel screen tube with mixed adhesive and insert into hole.
4. Insert steel sleeve slowly into screen tube (adhesive will displace).
5. Allow adhesive to cure (see cure schedule).
6. Drill through plastic plug in (inside) end of steel sleeve with 5/8" bit.
7. Drill completely through the wall with 5/8" carbide tipped concrete drill bit (rotation mode only).
8. Insert 5/8" rod through hole and attach metal plate and nut.

SET Technical Information

Load-Adjustment Factors for SET Adhesive in Normal-Weight Concrete: Edge Distance, Tension Load

How to use these charts:

1. The following tables are for reduced edge distance.
2. Locate the anchor size to be used for either a tension and/or shear load application.
3. Locate the embedment (E) at which the anchor is to be installed.
4. Locate the edge distance (C_{act}) at which the anchor is to be installed.
5. The load-adjustment factor (f_c) is the intersection of the row and column.
6. Multiply the allowable load by the applicable load-adjustment factor.
7. Reduction factors for multiple edges are multiplied together.
8. Adjustment factors do not apply to allowable steel strength values.
9. Adjustment factors are to be applied to allowable tension load based on bond strength values only.

Edge Distance Tension (f_c)

   * See page 13 for an explanation of the load table icons

Edge Dist. C_{act} (in.)	Dia.	$\frac{3}{8}$			$\frac{1}{2}$			$\frac{5}{8}$			$\frac{3}{4}$		
	Rebar	#3			#4			#5			#6		
	E	1 1/4	3 1/2	4 1/2	2 1/8	4 1/4	6	2 1/2	5	9 1/8	3 3/8	6 1/4	11 1/4
C_{cr}	2 1/8	5 1/4	6 1/4	3 1/4	6 1/8	9	3 3/8	7 1/2	14 1/8	5 1/8	10 1/8	16 1/4	
C_{min}	1 1/4	1 1/4	1 1/4	1 1/4	1 1/4	1 1/4	1 1/4	1 1/4	1 1/4	1 1/4	1 1/4	1 1/4	
f_{cmin}	0.65	0.65	0.69	0.65	0.65	0.59	0.48	0.48	0.64	0.48	0.48	0.57	
1 1/4		0.65	0.65	0.69	0.65	0.65	0.59	0.48	0.48	0.64	0.48	0.48	0.57
2		0.75	0.68	0.71	0.71	0.67	0.60	0.55	0.50	0.65	0.52	0.50	0.58
3		1.00	0.78	0.77	0.95	0.74	0.66	0.81	0.59	0.68	0.68	0.56	0.61
4			0.88	0.83	1.00	0.82	0.72	1.00	0.68	0.71	0.83	0.62	0.63
5			0.98	0.89		0.90	0.77		0.77	0.73	0.99	0.68	0.66
6			1.00	0.95		0.97	0.83		0.86	0.76	1.00	0.74	0.69
7				1.00		1.00	0.89		0.95	0.79		0.81	0.72
8							0.94		1.00	0.82		0.87	0.75
9							1.00			0.85		0.93	0.78
10										0.88		0.99	0.80
11										0.91		1.00	0.83
12										0.94			0.86
14										1.00			0.92
16													0.98
17													1.00

See Notes Below

Edge Distance Tension (f_c) (cont'd)

Edge Dist. C_{act} (in.)	Dia.	$\frac{7}{8}$			1			1 1/8			1 1/4				
	Rebar	#7			#8			#9			#10			#11	
	E	3 3/8	7 1/4	13 1/8	4 1/2	9	15	5 1/8	10 1/8	16 1/8	5 1/8	11 1/4	18 1/4	12 1/8	20 1/8
C_{cr}	5 1/8	11 1/8	19 1/8	6 1/4	13 1/2	22 1/2	7 1/4	15 1/4	25 1/8	8 1/2	16 1/8	28 1/8	28 1/8	28 1/8	
C_{min}	1 1/4	1 1/4	1 1/4	1 1/4	1 1/4	1 1/4	2 1/4	2 1/4	2 1/4	2 1/4	2 1/4	2 1/4	2 1/4	2 1/4	
f_{cmin}	0.48	0.48	0.52	0.48	0.48	0.47	0.58	0.58	0.51	0.58	0.58	0.51	0.58	0.51	
1 1/4		0.48	0.48	0.52	0.48	0.48	0.47								
2 1/4		0.61	0.53	0.55	0.58	0.52	0.50	0.58	0.51	0.58	0.58	0.51	0.58	0.51	
4		0.77	0.60	0.58	0.71	0.58	0.53	0.69	0.62	0.54	0.67	0.62	0.53	0.53	
6		1.00	0.70	0.63	0.92	0.67	0.58	0.85	0.69	0.58	0.82	0.68	0.57	0.57	
8			0.81	0.69	1.00	0.76	0.63	1.00	0.76	0.62	0.97	0.74	0.61	0.61	
10			0.91	0.74		0.85	0.68		0.82	0.67	1.00	0.80	0.65	0.65	
12			1.00	0.80		0.93	0.73		0.89	0.71		0.86	0.69	0.69	
14				0.85		1.00	0.78		0.96	0.75		0.91	0.73	0.73	
16				0.90			0.83		1.00	0.80		0.97	0.77	0.77	
18				0.96			0.89			0.84		1.00	0.80	0.81	
20				1.00			0.94			0.88			0.84	0.84	
24							1.00			0.97			0.92	0.92	
28										1.00			1.00	1.00	

1. E = Embedment depth (inches).
2. C_{act} = actual edge distance at which anchor is installed (inches).
3. C_{cr} = critical edge distance for 100% load (inches).
4. C_{min} = minimum edge distance for reduced load (inches).
5. f_c = adjustment factor for allowable load at actual edge distance.
6. f_{ccr} = adjustment factor for allowable load at critical edge distance. f_{ccr} is always = 1.00.
7. f_{cmin} = adjustment factor for allowable load at minimum edge distance.
8. $f_c = f_{cmin} + [(1 - f_{cmin}) (C_{act} - C_{min}) / (C_{cr} - C_{min})]$.

SET Technical Information

Epoxy Adhesives

Load-Adjustment Factors for SET Adhesive in Normal-Weight Concrete: Edge Distance, Shear Load

How to use these charts:

1. The following tables are for reduced edge distance.
2. Locate the anchor size to be used for either a tension and/or shear load application.
3. Locate the embedment (E) at which the anchor is to be installed.
4. Locate the edge distance (C_{act}) at which the anchor is to be installed.
5. The load-adjustment factor (f_c) is the intersection of the row and column.
6. Multiply the allowable load by the applicable load-adjustment factor.
7. Reduction factors for multiple edges are multiplied together.
8. Adjustment factors do not apply to allowable steel strength values.
9. Adjustment factors are to be applied to allowable shear load based on concrete edge distance values only.

Edge Distance Shear (f_c)

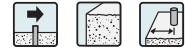

* See page 13 for an explanation of the load table icons

Edge Dist. Cact (in.)	Dia.	3/8"				1/2"				5/8"				3/4"			
	Rebar	#4				#5				#6							
E	1 3/4	3 1/2	4 1/2	2 1/8	4 1/4	4 1/4	6	2 1/2	5	5	9 1/8	3 3/8	6 1/4	6 3/4	11 1/4		
Ccr	5 1/4	5 1/4	5 1/4	6 3/8	6 3/8	6 3/8	6 3/8	7 1/2	7 1/2	7 1/2	7 1/2	10 1/8	10 1/8	10 1/8	10 1/8		
Cmin	1 3/4	1 3/4	1 3/4	1 3/4	1 3/4	1 3/4	1 3/4	1 3/4	1 3/4	1 3/4	1 3/4	1 3/4	1 3/4	1 3/4	1 3/4		
fcmin	0.49	0.32	0.35	0.37	0.20	0.25	0.24	0.18	0.15	0.21	0.19	0.16	0.16	0.18	0.15		
1 3/4		0.49	0.32	0.35	0.37	0.20	0.25	0.24	0.18	0.15	0.21	0.19	0.16	0.16	0.18	0.15	
2		0.53	0.37	0.40	0.40	0.24	0.29	0.28	0.22	0.19	0.24	0.23	0.19	0.19	0.20	0.18	
3		0.67	0.56	0.58	0.54	0.42	0.45	0.45	0.36	0.33	0.38	0.37	0.29	0.29	0.30	0.28	
4		0.82	0.76	0.77	0.68	0.59	0.61	0.61	0.50	0.48	0.52	0.51	0.39	0.39	0.40	0.38	
5		0.96	0.95	0.95	0.81	0.76	0.78	0.77	0.64	0.63	0.66	0.65	0.49	0.49	0.50	0.48	
6		1.00	1.00	1.00	0.95	0.94	0.94	0.94	0.79	0.78	0.79	0.79	0.59	0.59	0.60	0.58	
7					1.00	1.00	1.00	1.00	0.93	0.93	0.93	0.93	0.69	0.69	0.69	0.68	
8									1.00	1.00	1.00	1.00	0.79	0.79	0.79	0.78	
9													0.89	0.89	0.89	0.89	
10													0.99	0.99	0.99	0.99	
11													1.00	1.00	1.00	1.00	

See Notes Below

Edge Distance Shear (f_c) (cont'd)



* See page 13 for an explanation of the load table icons

Edge Dist. Cact (in.)	Dia.	3/8"				1"				1 1/8"				1 1/4"			
	Rebar	#7				#8				#9				#10			
E	3 3/8	7 3/4	7 3/4	13 3/8	4 1/2	9	9	15	5 1/8	10 3/8	16 3/8	5 3/8	11 1/4	18 3/4	12 3/8	20 3/8	
Ccr	11 3/8	11 3/8	11 3/8	11 3/8	13 1/2	13 1/2	13 1/2	13 1/2	15 1/4	15 1/4	15 1/4	16 3/8	16 3/8	16 3/8	18 3/8	18 3/8	
Cmin	1 3/4	1 3/4	1 3/4	1 3/4	1 3/4	1 3/4	1 3/4	1 3/4	2 3/4	2 3/4	2 3/4	2 3/4	2 3/4	2 3/4	2 3/4	2 3/4	
fcmin	0.14	0.13	0.14	0.10	0.14	0.10	0.12	0.10	0.17	0.16	0.12	0.17	0.16	0.12	0.16	0.12	
1 3/4		0.14	0.13	0.14	0.10	0.14	0.10	0.12	0.10								
2 3/4		0.23	0.22	0.23	0.19	0.21	0.18	0.19	0.18	0.17	0.16	0.12	0.17	0.16	0.12	0.12	
3		0.25	0.24	0.25	0.21	0.23	0.20	0.21	0.20	0.19	0.18	0.14	0.18	0.17	0.14	0.13	
4		0.34	0.33	0.34	0.31	0.30	0.27	0.29	0.27	0.25	0.24	0.21	0.24	0.23	0.20	0.19	
5		0.42	0.42	0.42	0.40	0.38	0.35	0.36	0.35	0.32	0.31	0.28	0.30	0.29	0.26	0.24	
6		0.51	0.50	0.51	0.49	0.45	0.43	0.44	0.43	0.39	0.38	0.35	0.36	0.35	0.32	0.30	
7		0.60	0.59	0.60	0.58	0.52	0.50	0.51	0.50	0.45	0.45	0.42	0.42	0.41	0.38	0.36	
8		0.68	0.68	0.68	0.67	0.60	0.58	0.59	0.58	0.52	0.51	0.49	0.48	0.47	0.45	0.41	
9		0.77	0.77	0.77	0.76	0.67	0.66	0.66	0.66	0.59	0.58	0.56	0.54	0.53	0.51	0.47	
10		0.86	0.86	0.86	0.85	0.74	0.73	0.74	0.73	0.65	0.65	0.63	0.60	0.59	0.57	0.52	
11		0.95	0.94	0.95	0.94	0.82	0.81	0.81	0.81	0.72	0.71	0.70	0.65	0.65	0.63	0.58	
12		1.00	1.00	1.00	1.00	0.89	0.89	0.89	0.89	0.78	0.78	0.77	0.71	0.71	0.70	0.63	
13						0.96	0.96	0.96	0.96	0.85	0.85	0.84	0.77	0.77	0.76	0.69	
14						1.00	1.00	1.00	1.00	0.92	0.92	0.91	0.83	0.83	0.82	0.74	
15										0.98	0.98	0.98	0.89	0.89	0.88	0.80	
16										1.00	1.00	1.00	0.95	0.95	0.95	0.85	
17													1.00	1.00	1.00	0.91	
18 3/8																1.00	

1. E = Embedment depth (inches).
2. C_{act} = actual edge distance at which anchor is installed (inches).
3. C_{cr} = critical edge distance for 100% load (inches).
4. C_{min} = minimum edge distance for reduced load (inches).
5. f_c = adjustment factor for allowable load at actual edge distance.
6. f_{cr} = adjustment factor for allowable load at critical edge distance. f_{cr} is always = 1.00.
7. f_{cmin} = adjustment factor for allowable load at minimum edge distance.
8. $f_c = f_{cmin} + [(1 - f_{cmin}) (C_{act} - C_{min}) / (C_{cr} - C_{min})]$.

SET Technical Information

Epoxy Adhesives

Load-Adjustment Factors for SET Adhesive in Normal-Weight Concrete: Spacing, Tension Load

How to use these charts:

1. The following tables are for reduced spacing.
2. Locate the anchor size to be used for either a tension and/or shear load application.
3. Locate the embedment (E) at which the anchor is to be installed.
4. Locate the spacing (S_{act}) at which the anchor is to be installed.
5. The load-adjustment factor (f_s) is the intersection of the row and column.
6. Multiply the allowable load by the applicable load-adjustment factor.
7. Reduction factors for multiple spacings are multiplied together.
8. Adjustment factors do not apply to allowable steel strength values.
9. Adjustment factors are to be applied to allowable tension load based on bond strength values only.

Spacing Tension (f_s)

S _{act} (in.)	Dia.	¾"				1"			1½"			2"		
	Rebar	#3	#4	#5	#6	#4	#5	#6	#5	#6	#6	#6	#6	
E	1¼"	3½"	4½"	2½"	4¼"	6"	2½"	5"	9¾"	3¾"	6¼"	11¼"		
S _{cr}	7"	14"	18"	8½"	17"	24"	10"	20"	37½"	13½"	27"	45"		
S _{min}	7/8"	1¾"	2¼"	1½"	2½"	3"	1¼"	2½"	4¼"	1¾"	3¾"	5¾"		
f _{smin}	0.52	0.89	0.90	0.52	0.89	0.90	0.52	0.89	0.90	0.52	0.89	0.90		
7/8"	0.52													
1"	0.53													
2"	0.61	0.89		0.58			0.56				0.53			
4"	0.76	0.91	0.91	0.71	0.90	0.90	0.67	0.90			0.61	0.89		
6"	0.92	0.93	0.92	0.84	0.92	0.91	0.78	0.91	0.90	0.69	0.90	0.90		
8"	1.00	0.95	0.94	0.97	0.93	0.92	0.89	0.92	0.91	0.78	0.91	0.91		
10"		0.96	0.95	1.00	0.95	0.93	1.00	0.94	0.92	0.86	0.92	0.91		
12"		0.98	0.96		0.96	0.94		0.95	0.92	0.94	0.93	0.92		
14"		1.00	0.97		0.98	0.95		0.96	0.93	1.02	0.94	0.92		
16"			0.99		0.99	0.96		0.97	0.93		0.95	0.93		
18"			1.00		1.00	0.97		0.99	0.94		0.96	0.93		
20"						0.98		1.00	0.95		0.97	0.94		
24"						1.00			0.96		0.99	0.95		
28"									0.97		1.00	0.96		
32"									0.98			0.97		
36"									1.00			0.98		
40"									1.00			0.99		
45"												1.00		

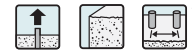

* See page 13 for an explanation of the load table icons

1. E = Embedment depth (inches).
2. S_{act} = actual spacing distance at which anchors are installed (inches).
3. S_{cr} = critical spacing distance for 100% load (inches).
4. S_{min} = minimum spacing distance for reduced load (inches).
5. f_s = adjustment factor for allowable load at actual spacing distance.
6. $f_{s_{cr}}$ = adjustment factor for allowable load at critical spacing distance. $f_{s_{cr}}$ is always = 1.00.
7. $f_{s_{min}}$ = adjustment factor for allowable load at minimum spacing distance.
8. $f_s = f_{s_{min}} + [(1 - f_{s_{min}}) (S_{act} - S_{min}) / (S_{cr} - S_{min})]$.

Spacing Tension (f_s) (cont'd)

S _{act} (in.)	Dia.	¾"			1"		1½"			2"			2½"	
	Rebar	#7	#8	#9	#8	#9	#9	#10	#10	#11	#11	#11	#11	
E	3¾"	7¾"	13¾"	4½"	9"	15"	5½"	10½"	16½"	5½"	11¼"	18½"	12½"	20½"
S _{cr}	15½"	31"	52½"	18"	36"	60"	20½"	40½"	67½"	22½"	45"	75"	49½"	82½"
S _{min}	2"	3¾"	6¾"	2¼"	4½"	7½"	2½"	5½"	8½"	2¾"	5¾"	9¾"	6¼"	10¾"
f _{smin}	0.52	0.89	0.90	0.52	0.89	0.90	0.52	0.89	0.90	0.52	0.89	0.90	0.89	0.90
2"	0.52													
3"	0.56			0.54			0.53			0.52				
4"	0.59	0.89		0.57			0.56			0.55				
5"	0.63	0.89		0.60	0.89		0.58			0.57				
6"	0.66	0.90		0.63	0.90		0.61	0.89		0.60	0.89			
8"	0.73	0.91	0.90	0.70	0.90	0.90	0.66	0.90		0.65	0.90		0.89	
10"	0.80	0.91	0.91	0.76	0.91	0.90	0.72	0.91	0.90	0.69	0.90	0.90	0.90	
12"	0.88	0.92	0.91	0.82	0.92	0.91	0.77	0.91	0.91	0.74	0.91	0.90	0.90	0.90
14"	0.95	0.93	0.92	0.88	0.92	0.91	0.83	0.92	0.91	0.79	0.91	0.91	0.91	0.91
16"	1.00	0.94	0.92	0.94	0.93	0.92	0.88	0.92	0.91	0.84	0.92	0.91	0.91	0.91
20"		0.96	0.93	1.00	0.94	0.92	0.99	0.94	0.92	0.94	0.93	0.92	0.92	0.91
24"		0.97	0.94		0.96	0.93	1.00	0.95	0.93	1.00	0.94	0.92	0.94	0.92
28"		0.99	0.95		0.97	0.94		0.96	0.93		0.95	0.93	0.95	0.92
32"		1.00	0.96		0.99	0.95		0.97	0.94		0.96	0.93	0.96	0.93
36"			0.96		1.00	0.95		0.99	0.95		0.97	0.94	0.97	0.94
40"			0.97			0.96		1.00	0.95		0.99	0.95	0.98	0.94
50"			0.99			0.98			0.97		1.00	0.96	1.00	0.95
60"			1.00			1.00			0.99			0.98		0.97
70"									1.00			0.99		0.98
75"												1.00		0.99
82½"														1.00



* See page 13 for an explanation of the load table icons

SET Technical Information

Epoxy Adhesives

Load-Adjustment Factors for SET Adhesive in Normal-Weight Concrete: Spacing, Shear Load

How to use these charts:

1. The following tables are for reduced spacing.
2. Locate the anchor size to be used for either a tension and/or shear load application.
3. Locate the embedment (E) at which the anchor is to be installed.
4. Locate the spacing (S_{act}) at which the anchor is to be installed.
5. The load-adjustment factor (f_s) is the intersection of the row and column.
6. Multiply the allowable load by the applicable load-adjustment factor.
7. Reduction factors for multiple spacings are multiplied together.
8. Adjustment factors do not apply to allowable steel strength values.
9. Adjustment factors are to be applied to allowable shear load based on concrete edge distance values only.

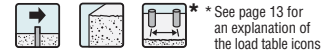

Spacing Shear (f_s)

S_{act} (in.)	Dia.	$\frac{3}{8}$		$\frac{1}{2}$		$\frac{5}{8}$		$\frac{3}{4}$		$\frac{7}{8}$		1		$1\frac{1}{8}$		$1\frac{1}{4}$		
	Rebar				#4		#5		#6		#7		#8		#9		#10	
E		1¾	3½	2½	4¼	2½	5	3¾	6¼	3¾	7¾	4½	9	5½	10½	5½	11¼	12¾
S_{cr}		2½	5¼	3¼	6¾	3¾	7½	5½	10½	5½	11½	6¼	13½	7¼	15¼	8½	16½	18½
S_{min}		7/8	1¾	1½	2½	1¼	2½	1¾	3¾	2	3¾	2¼	4½	2¾	5½	2¾	5½	6¼
f_{smin}		0.90	0.83	0.90	0.83	0.90	0.83	0.90	0.83	0.90	0.83	0.90	0.83	0.90	0.83	0.90	0.83	0.83
$\frac{7}{8}$		0.90																
1		0.91																
$1\frac{1}{2}$		0.94		0.92		0.91												
2		0.96	0.84	0.94		0.93		0.91		0.90								
$2\frac{1}{2}$		0.99	0.87	0.96	0.85	0.95	0.83	0.92		0.91		0.91						
3		1.00	0.89	0.99	0.87	0.97	0.85	0.94		0.93		0.92		0.91		0.90		
$3\frac{1}{2}$			0.92	1.00	0.89	0.99	0.86	0.95	0.83	0.94		0.93		0.92		0.91		
4			0.94		0.91	1.00	0.88	0.97	0.85	0.95	0.83	0.94		0.93		0.92		
5			0.99		0.95		0.92	1.00	0.87	0.98	0.85	0.96	0.84	0.95		0.94		
6			1.00		0.99		0.95		0.90	1.00	0.88	0.98	0.86	0.97	0.84	0.96	0.84	
7					1.00		0.98		0.92		0.90	1.00	0.88	0.99	0.86	0.97	0.85	0.84
8							1.00		0.95		0.92		0.90	1.00	0.88	0.99	0.87	0.85
9									0.97		0.94		0.92		0.90	1.00	0.88	0.87
10									1.00		0.96		0.93		0.91		0.90	0.88
12											1.00		0.97		0.95		0.93	0.91
14													1.00		0.98		0.96	0.94
16															1.00		0.99	0.96
17																	1.00	0.98
18%																		1.00

1. E = Embedment depth (inches).
2. S_{act} = actual spacing distance at which anchors are installed (inches).
3. S_{cr} = critical spacing distance for 100% load (inches).
4. S_{min} = minimum spacing distance for reduced load (inches).
5. f_s = adjustment factor for allowable load at actual spacing distance.
6. f_{scr} = adjustment factor for allowable load at critical spacing distance. f_{scr} is always = 1.00.
7. f_{smin} = adjustment factor for allowable load at minimum spacing distance.
8. $f_s = f_{smin} + [(1 - f_{smin}) (S_{act} - S_{min}) / (S_{cr} - S_{min})]$.

SET Technical Information

Load-Adjustment Factors for SET Adhesive in Sand-Lightweight Concrete: Edge Distance, Tension and Shear Loads

How to use these charts:

1. The following tables are for reduced edge distance only.
2. Locate the anchor size to be used for either a tension and/or shear load application.
3. Locate the embedment (E) at which the anchor is to be installed.
4. Locate the edge distance (C_{act}) at which the anchor is to be installed.
5. The load-adjustment factor (f_c) is the intersection of the row and column.
6. Multiply the allowable load by the applicable load-adjustment factor.
7. Reduction factors for multiple edges are multiplied together.
8. Adjustment factors do not apply to allowable steel strength values.
9. Adjustment factors are to be applied to allowable tension load based on bond strength values or allowable shear load based on concrete edge distance values only.

Edge Distance Tension (f_c)



* See page 13 for an explanation of the load table icons

Edge Dist. C_{act} (in.)	Dia.	3/8		1/2		5/8	
	E	1 1/4	3 1/2	2 1/8	4 1/4	2 1/2	5
	C_{cr}	2 5/8	5 1/4	3 3/8	6 3/8	3 3/4	7 1/2
	C_{min}	1 1/4	1 1/4	1 1/4	1 1/4	1 1/4	1 1/4
	f_{cmin}	0.65	0.65	0.65	0.65	0.48	0.48
1 1/4		0.65	0.65	0.65	0.65	0.48	0.48
2		0.75	0.68	0.71	0.67	0.55	0.50
2 1/4		0.85	0.70	0.78	0.69	0.61	0.53
2 1/2		0.95	0.73	0.84	0.71	0.68	0.55
2 3/4		1.00	0.75	0.90	0.73	0.74	0.57
3			0.78	0.97	0.74	0.81	0.59
3 1/4			0.80	1.00	0.76	0.87	0.62
3 1/2			0.83		0.78	0.94	0.64
3 3/4			0.85		0.80	1.00	0.66
4			0.88		0.82		0.68
4 1/4			0.90		0.84		0.71
4 1/2			0.93		0.86		0.73
4 3/4			0.95		0.88		0.75
5			0.98		0.90		0.77
5 1/4			1.00		0.91		0.80
5 1/2					0.93		0.82
5 3/4					0.95		0.84
6					0.97		0.86
6 1/4					0.99		0.89
6 1/2					1.00		0.91
6 3/4							0.93
7							0.95
7 1/4							0.98
7 1/2							1.00

Edge Distance Shear (f_c)



* See page 13 for an explanation of the load table icons

Edge Dist. C_{act} (in.)	Dia.	3/8		1/2		5/8	
	E	1 1/4	3 1/2	2 1/8	4 1/4	2 1/2	5
	C_{cr}	2 5/8	5 1/4	3 3/8	6 3/8	3 3/4	7 1/2
	C_{min}	1 1/4	1 1/4	1 1/4	1 1/4	1 1/4	1 1/4
	f_{cmin}	0.25	0.25	0.20	0.20	0.15	0.15
1 1/4		0.25	0.25	0.20	0.20	0.15	0.15
2		0.46	0.30	0.35	0.24	0.26	0.19
2 1/4		0.68	0.36	0.49	0.29	0.36	0.22
2 1/2		0.89	0.41	0.64	0.33	0.47	0.26
2 3/4		1.00	0.46	0.78	0.37	0.58	0.30
3			0.52	0.93	0.42	0.68	0.33
3 1/4			0.57	1.00	0.46	0.79	0.37
3 1/2			0.63		0.50	0.89	0.41
3 3/4			0.68		0.55	1.00	0.45
4			0.73		0.59		0.48
4 1/4			0.79		0.63		0.52
4 1/2			0.84		0.68		0.56
4 3/4			0.89		0.72		0.59
5			0.95		0.76		0.63
5 1/4			1.00		0.81		0.67
5 1/2					0.85		0.70
5 3/4					0.89		0.74
6					0.94		0.78
6 1/4					0.98		0.82
6 1/2					1.00		0.85
6 3/4							0.89
7							0.93
7 1/4							0.96
7 1/2							1.00

1. E = Embedment depth (inches).
2. C_{act} = actual edge distance at which anchor is installed (inches).
3. C_{cr} = critical edge distance for 100% load (inches).
4. C_{min} = minimum edge distance for reduced load (inches).
5. f_c = adjustment factor for allowable load at actual edge distance.
6. f_{ccr} = adjustment factor for allowable load at critical edge distance. f_{ccr} is always = 1.00.
7. f_{cmin} = adjustment factor for allowable load at minimum edge distance.
8. $f_c = f_{cmin} + [(1 - f_{cmin}) (C_{act} - C_{min}) / (C_{cr} - C_{min})]$.



SET Technical Information

Epoxy Adhesives

Load-adjustment factors for SET adhesive in face of wall installation in 8" grout-filled CMU: end/edge distance and spacing, tension and shear loads



How to use these charts:

1. The following tables are for reduced end and edge distance and spacing.
2. Locate the anchor size to be used for either a tension and/or shear load application.
3. Locate the embedment (E) at which the anchor is to be installed.
4. Locate the end or edge distance (C_{act}) or spacing (S_{act}) at which the anchor is to be installed.
5. The load-adjustment factor (f_c or f_s) is the intersection of the row and column.
6. Multiply the allowable load by the applicable load-adjustment factor.
7. Reduction factors for multiple edges or spacing are multiplied together.
8. Adjustment factors do not apply to allowable steel strength values.
9. Adjustment factors are to be applied to allowable Tension or Shear Load Based on CMU Strength values only.

End Distance Tension (f_c)    *

C_{act} (in.)	Dia.	1/2	5/8	3/4
	E	4 1/4	5	6 3/4
	C_{cr}	17	20	27
	C_{min}	4	4	4
	f_{cmin}	1.00	0.84	0.54**
4		1.00	0.84	0.54
8		1.00	0.88	0.62
12		1.00	0.92	0.70
16		1.00	0.96	0.78
17		1.00	0.97	0.80
20			1.00	0.86
24				0.94
27				1.00

* See page 13 for an explanation of the load table icons



Edge Distance Tension (f_c)    *

C_{act} (in.)	Dia.	1/2	5/8	3/4
	E	4 1/4	5	6 3/4
	C_{cr}	17	20	27
	C_{min}	4	4	4
	f_{cmin}	1.00	0.84	0.54**
4		1.00	0.84	0.54
8		1.00	0.88	0.62
12		1.00	0.92	0.70
16		1.00	0.96	0.78
17		1.00	0.97	0.80
20			1.00	0.86
24				0.94
27				1.00



* See page 13 for an explanation of the load table icons

See Notes Below

See Notes Below



End and Edge Distance Shear (f_c) Shear Load Perpendicular to End or Edge    *

C_{act} (in.)	Dia.	1/2	5/8	3/4
	E	4 1/4	5	6 3/4
	C_{cr}	17	20	27
	C_{min}	4	4	4
	f_{cmin}	0.43	0.25	0.25
4		0.43	0.25	0.25
8		0.61	0.44	0.38
12		0.78	0.63	0.51
16		0.96	0.81	0.64
17		1.00	0.86	0.67
20			1.00	0.77
24				0.90
27				1.00



End and Edge Distance Shear (f_c) Shear Load Parallel to End or Edge    *

C_{act} (in.)	Dia.	1/2	5/8	3/4
	E	4 1/4	5	6 3/4
	C_{cr}	17	20	27
	C_{min}	4	4	4
	f_{cmin}	0.95	0.51	0.45
4		0.95	0.51	0.45
8		0.97	0.63	0.55
12		0.98	0.76	0.64
16		1.00	0.88	0.74
17		1.00	0.91	0.76
20			1.00	0.83
24				0.93
27				1.00

1. E = Embedment depth (inches).
2. C_{act} = actual end or edge distance at which anchor is installed (inches).
3. C_{cr} = critical end or edge distance for 100% load (inches).
4. C_{min} = minimum end or edge distance for reduced load (inches).
5. f_c = adjustment factor for allowable load at actual end or edge distance.
6. f_{ccr} = adjustment factor for allowable load at critical end or edge distance. f_{ccr} is always = 1.00.
7. f_{cmin} = adjustment factor for allowable load at minimum end or edge distance.
8. $f_c = f_{cmin} + [(1 - f_{cmin})(C_{act} - C_{min}) / (C_{cr} - C_{min})]$.

Spacing Tension (f_s)    *

S_{act} (in.)	Dia.	1/2	5/8	3/4
	E	4 1/4	5	6 3/4
	S_{cr}	17	20	27
	S_{min}	8	8	8
	f_{smin}	0.89	0.81	0.59
8		0.89	0.81	0.59
12		0.94	0.87	0.68
16		0.99	0.94	0.76
17		1.00	0.95	0.78
20			1.00	0.85
24				0.94
27				1.00

Spacing Shear (f_s)    *

S_{act} (in.)	Dia.	1/2	5/8	3/4
	E	4 1/4	5	6 3/4
	S_{cr}	17	20	27
	S_{min}	8	8	8
	f_{smin}	1.00	1.00	1.00
8		1.00 for all spacing ≥ 8 in.		
12				
16				
17				
20				
24				
27				

1. E = Embedment depth (inches).
2. S_{act} = actual spacing distance at which anchors are installed (inches).
3. S_{cr} = critical spacing distance for 100% load (inches).
4. S_{min} = minimum spacing distance for reduced load (inches).
5. f_s = adjustment factor for allowable load at actual spacing distance.
6. f_{scr} = adjustment factor for allowable load at critical spacing distance. f_{scr} is always = 1.00.
7. f_{smin} = adjustment factor for allowable load at minimum spacing distance.
8. $f_s = f_{smin} + [(1 - f_{smin})(S_{act} - S_{min}) / (S_{cr} - S_{min})]$.

ET-HP™ (formerly ET) Anchoring Adhesive

Epoxy Adhesives

ET-HP™ is a two-component, high solids, epoxy-based system for use as a high-strength, non-shrink anchor grouting material. Resin and hardener are dispensed and mixed simultaneously through the mixing nozzle. ET-HP meets the ASTM C-881 specifications for Type I, II, IV and V, Grade 3, Classes B and C, except gel time.

- USES:**
- Threaded rod anchoring
 - Rebar doweling
 - Bonding hardened concrete to hardened concrete
 - Pick-proof sealant around doors, windows and fixtures
 - Paste-over for crack injection

CODES: ICC-ES ER-4945 (URM); City of L.A. RR25185, RR25120; Multiple DOT Listings.

⚠ The load tables list values based upon results from the most recent testing and may not reflect those in current code reports. Where code jurisdictions apply, consult the current reports for applicable load values.

APPLICATION: Surfaces to receive epoxy must be clean. For installations in or through standing water, see page 225 for details. The base material temperature must be 40°F or above at the time of installation. For best results, material should be 70°F - 80°F at the time of application. Cartridges should not be immersed in water to facilitate warming. To warm cold material, the cartridges should be stored in a warm, uniformly heated area or storage container for a sufficient time to allow epoxy to warm completely. Mixed material in nozzle can harden in 5–7 minutes at a temperature of 40°F or above.

INSTALLATION: See pages 70–71

SHELF LIFE: 24 months from date of manufacture in unopened container

STORAGE CONDITIONS: For best results store between 45°F - 90°F. To store partially used cartridges, leave hardened nozzle in place. To re-use, attach new nozzle.

COLOR: Resin – white, hardener – black. When properly mixed, ET-HP adhesive will be a uniform medium gray color.

CLEAN UP: Uncured material — Wipe up with cotton cloths. If desired scrub area with abrasive, waterbased cleaner and flush with water. If approved, solvents such as ketones (MEK, acetone, etc.), lacquer thinner, or adhesive remover can be used. **DO NOT USE SOLVENTS TO CLEAN ADHESIVE FROM SKIN.** Take appropriate precautions when handling flammable solvents. Solvents may damage surfaces to which they are applied. Cured material: Chip or grind off surface.

TEST CRITERIA: Anchors installed with ET-HP™ adhesive have been tested in accordance with ICC-ES's *Acceptance Criteria for Adhesive Anchors in Masonry Elements (AC58)* and *Adhesive Anchors in Concrete Elements (AC308)*.

In addition, anchors installed with ET-HP adhesive have been tested in accordance with ICC-ES's *Acceptance Criteria for Unreinforced Masonry Anchors (AC60)*.

PROPERTY	TEST METHOD	RESULTS
Consistency (77°F)	ASTM C 881	Non-sag/thixotropic paste
Heat deflection	ASTM D 648	168°F (76°C)
Bond strength (moist cure)	ASTM C 882	2,030 psi (2 days) 4,240 psi (14 days)
Water absorption	ASTM D 570	0.19% (24 hours)
Compressive yield strength	ASTM D 695	9,174 psi (24 hours) 13,390 psi (7 days)
Compressive modulus	ASTM D 695	658,200 psi (7 days)
Gel time (77°F)	ASTM C 881	10 min. – 60 gram mass 30 min – Thin film

CHEMICAL RESISTANCE Very good to excellent against distilled water, inorganic acids and alkalis. Fair to good against organic acids and alkalis, and many organic solvents. Poor against ketones. For more detailed information, visit www.strongtie.com.



ET-HP22



ET-HP56



EMN22i

EDT22S

ET-HP Cartridge Systems

Model No.	Capacity ounces (cubic inches)	Cartridge Type	Carton Quantity	Dispensing Tool(s)	Mixing4 Nozzle
ET-HP22	22 (39.7)	side-by-side	10	EDT22S, EDTA22P or EDTA22CKT	EMN22i
ET-HP56	56 (101.1)	side-by-side	6	EDTA56P	EMN22i or EMN50

1. Cartridge and bulk estimation guides are available on pages 48–51.
2. Detailed information on dispensing tools, mixing nozzles and other adhesive accessories is available on pages 72–77.
3. Use only appropriate Simpson Strong-Tie® mixing nozzle in accordance with Simpson Strong-Tie instructions. Modification or improper use of mixing nozzle may impair epoxy performance.

SUGGESTED SPECIFICATIONS: Anchoring adhesive shall be a two-component high solids epoxy based system supplied in manufacturer's standard side-by-side cartridge and dispensed through a static-mixing nozzle supplied by the manufacturer. Epoxy shall meet the minimum requirements of ASTM C-881 specification for Type I, II, IV, and V, Grade 3, Class B and C, except gel time, and must develop a minimum 13,390 psi compressive yield strength after 7 day cure. Epoxy must have a heat deflection temperature of a minimum 168°F (76°C). Adhesive shall be ET-HP™ adhesive from Simpson Strong-Tie, Pleasanton, CA. Anchors shall be installed per Simpson Strong-Tie instructions for ET-HP™ adhesive.

ACCESSORIES: See pages 72–77 for information on dispensing tools, mixing nozzles and other accessories.

IMPORTANT – See Pages 70–71 for Installation Instructions

ET-HP™ (formerly ET) Anchoring Adhesive

Epoxy Adhesives

Cure Schedule

Base Material Temperature		Cure Time
°F	°C	
40	4	72 hrs.
60	16	24 hrs.
80	27	24 hrs.
100	38	12 hrs.

In-Service Temperature Sensitivity

Base Material Temperature		Percent Allowable Load
°F	°C	
40	4	100%
70	21	100%
110	43	100%
135	57	85%
150	66	69%
180	82	58%

1. Refer to temperature-sensitivity chart for allowable bond strength reduction for temperature. See page 225 for more information.
2. Percent allowable load may be linearly interpolated for intermediate base material temperatures.
3. °C = (°F-32) / 1.8

ET-HP Epoxy Anchor Installation Information and Additional Data for Threaded Rod and Rebar in Normal-Weight Concrete¹

Characteristic	Symbol	Units	Nominal Anchor Diameter (in.) / Rebar Size						
			3/8 / #3	1/2 / #4	5/8 / #5	3/4 / #6	7/8 / #7	1 / #8	1 1/4 / #10
Installation Information									
Drill Bit Diameter	d_{hole}	in.	1/2	5/8	3/4	7/8	1	1 1/8	1 3/8
Maximum Tightening Torque	T_{inst}	ft-lb	10	20	30	45	60	80	125
Permitted Embedment Depth Range ²	Minimum	h_{ef}	2 3/8	2 3/4	3 1/8	3 1/2	3 3/4	4	5
	Maximum	h_{ef}	4 1/2	6	7 1/2	9	10 1/2	12	15
Minimum Concrete Thickness	h_{min}	in.	$h_{ef} + 5d_o$						
Critical Edge Distance	C_{ac}	in.	$2.75 \times h_{ef}$						
Minimum Edge Distance	C_{min}	in.	1 3/4						2 3/4
Minimum Anchor Spacing	S_{min}	in.	3						6

1. The information presented in this table is to be used in conjunction with the design criteria of ICC-ES AC308.
2. Minimum and maximum embedment depths are listed in accordance with ICC-ES AC308 requirements.

ET-HP™ (formerly ET) Anchoring Adhesive

ET-HP Epoxy Anchor Tension Strength Design Data for Threaded Rod and Rebar in Normal-Weight Concrete^{1,11}

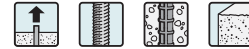

* See page 13 for an explanation of the load table icons

Characteristic		Symbol	Units	Nominal Anchor Diameter (in.)						
				3/8 / #3	1/2 / #4	5/8 / #5	3/4 / #6	7/8 / #7	1 / #8	1 1/4 / #10
Steel Strength in Tension										
Threaded Rod	Minimum Tensile Stress Area	A_{se}	in ²	0.078	0.142	0.226	0.334	0.462	0.606	0.969
	Tension Resistance of Steel - ASTM A193, Grade B7	N_{sa}	lb.	9,750	17,750	28,250	41,750	57,750	75,750	121,125
	- ASTM F1554, Grade 36			4,525	8,235	13,110	19,370	26,795	35,150	56,200
	- Type 410 Stainless (ASTM A193, Grade B6)			8,580	15,620	24,860	36,740	50,820	66,660	106,590
	- Type 304 and 316 Stainless (ASTM A193, Grade B8 and B8M)			4,445	8,095	12,880	19,040	26,335	34,540	55,235
Strength Reduction Factor - Steel Failure	ϕ	—	0.75 ⁸							
Rebar	Minimum Tensile Stress Area	A_{se}	in ²	0.11	0.20	0.31	0.44	0.60	0.79	1.23
	Tension Resistance of Steel – Rebar (ASTM A615, Grade 60)	N_{sa}	lb.	9,900	18,000	27,900	39,600	54,000	71,100	110,700
	Strength Reduction Factor – Steel Failure	ϕ	—	0.65 ⁸						
Concrete Breakout Strength in Tension (2,500 psi ≤ f'_c ≤ 8,000 psi)										
Effectiveness Factor - Uncracked Concrete		k_{uncr}	—	24						
Strength Reduction Factor - Breakout Failure		ϕ	—	0.65 ¹⁰						
Bond Strength in Tension (2,500 psi ≤ f'_c ≤ 8,000 psi)										
Temp. Range 1 for Uncracked Concrete ^{2,4,5}	Characteristic Bond Strength ⁷	$\tau_{k,uncr}$	psi	1,590	1,535	1,485	1,435	1,380	1,330	1,225
Temp. Range 2 for Uncracked Concrete ^{3,4,5}	Characteristic Bond Strength ^{6,7}	$\tau_{k,uncr}$	psi	435	420	405	395	380	365	335
Bond Strength in Tension – Bond Strength Reduction Factors for Periodic or Continuous Special Inspection										
Strength Reduction Factor - Dry Concrete		ϕ_{dry}	—	0.65 ⁹						
Strength Reduction Factor - Water-saturated Concrete		ϕ_{sat}	—	0.45 ⁹						

- The information presented in this table is to be used in conjunction with the design criteria of ICC-ES AC308, except as modified below.
- Temperature Range 1: Maximum short-term temperature of 110°F (43°C). Maximum long-term temperature of 75°F (24°C).
- Temperature Range 2: Maximum short-term temperature of 150°F (66°C). Maximum long-term temperature of 110°F (43°C).
- Short-term concrete temperatures are those that occur over short intervals (diurnal cycling).
- Long-term concrete temperature are constant temperatures over a significant time period.
- For anchors that only resist wind or seismic loads, bond strengths may be multiplied by 2.25.
- For anchors installed in overhead and subjected to tension resulting from sustained loading, multiply the value calculated for N_a according to ICC-ES AC308 by 0.75.
- The value of ϕ applies when the load combinations of ACI 318 Section 9.2 are used. If the load combinations of ACI 318 Appendix C are used, refer to Section D.4.5 to determine the appropriate value of ϕ .
- The value of ϕ applies when both the load combinations of ACI 318 Section 9.2 are used and the requirements of Section D.4.4(c) for Condition B are met. If the load combinations of ACI 318 Appendix C are used, refer to Section D.4.5 to determine the appropriate value of ϕ .
- The value of ϕ applies when both the load combinations of ACI 318 Section 9.2 are used and the requirements of Section D.4.4(c) for Condition B are met. If the load combinations of ACI 318 Appendix C are used, refer to Section D.4.5 to determine the appropriate value of ϕ .
- The value of ϕ applies when both the load combinations of ACI 318 Section 9.2 are used and the requirements of Section D.4.4(c) for Condition B are met. If the load combinations of ACI 318 Appendix C are used, refer to Section D.4.5 to determine the appropriate value of ϕ .
- The value of ϕ applies when both the load combinations of ACI 318 Section 9.2 are used and the requirements of Section D.4.4(c) for Condition B are met. If the load combinations of ACI 318 Appendix C are used, refer to Section D.4.5 to determine the appropriate value of ϕ .
- Sand-lightweight and all-lightweight concrete are beyond the scope of this table.

ET-HP™ (formerly ET) Anchoring Adhesive

Epoxy Adhesives

ET-HP™ Epoxy Anchor Shear Strength Design Data for Threaded Rod and Rebar in Normal-Weight Concrete^{1,5}

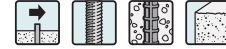

* See page 13 for an explanation of the load table icons

Characteristic		Symbol	Units	Nominal Anchor Diameter (in.) / Rebar Size						
				3/8 / #3	1/2 / #4	5/8 / #5	3/4 / #6	7/8 / #7	1 / #8	1 1/4 / #10
Steel Strength in Shear										
Threaded Rod	Minimum Shear Stress Area	A_{se}	in ²	0.078	0.142	0.226	0.334	0.462	0.606	0.969
	Shear Resistance of Steel - ASTM A193, Grade B7	V_{sa}	lb.	4,875	10,650	16,950	25,050	34,650	45,450	72,675
	- ASTM F1554, Grade 36			2,260	4,940	7,865	11,625	16,080	21,090	33,720
	- Type 410 Stainless (ASTM A193, Grade B6)			4,290	9,370	14,910	22,040	30,490	40,000	63,955
	- Type 304 and 316 Stainless (ASTM A193, Grade B8 and B8M)			2,225	4,855	7,730	11,420	15,800	20,725	33,140
Strength Reduction Factor - Steel Failure	ϕ	—	0.65 ²							
Rebar	Minimum Shear Stress Area	A_{se}	in ²	0.11	0.20	0.31	0.44	0.60	0.79	1.23
	Shear Resistance of Steel – Rebar (ASTM A615, Grade 60)	V_{sa}	lb.	4,950	10,800	16,740	23,760	32,400	42,660	66,420
	Strength Reduction Factor – Steel Failure	ϕ	—	0.60 ²						
Concrete Breakout Strength in Shear										
Outside Diameter of Anchor		d_o	in.	0.375	0.500	0.625	0.750	0.875	1.000	1.250
Load Bearing Length of Anchor in Shear		ℓ_e	in.	h _{ef}						
Strength Reduction Factor – Breakout Failure		ϕ	—	0.70 ³						
Concrete Pryout Strength in Shear										
Coefficient for Pryout Strength		k_{cp}	—	2.0						
Strength Reduction Factor – Pryout Failure		ϕ	—	0.70 ⁴						

- The information presented in this table is to be used in conjunction with the design criteria of ICC-ES AC308, except as modified below.
- The value of ϕ applies when the load combinations of ACI 318 Section 9.2 are used. If the load combinations of ACI 318 Appendix C are used, refer to Section D.4.5 to determine the appropriate value of ϕ .
- The value of ϕ applies when both the load combinations of ACI 318 Section 9.2 are used and the requirements of Section D.4.4(c) for Condition B are met. If the load combinations of ACI 318 Section 9.2 are used and the requirements of Section D.4.4(c) for Condition A are met, refer to Section D.4.4 to determine the appropriate value of ϕ . If the load combinations of ACI 318 Appendix C are used, refer to Section D.4.5 to determine the appropriate value of ϕ .
- The value of ϕ applies when both the load combinations of ACI 318 Section 9.2 are used and the requirements of Section D.4.4(c) for Condition B are met. If the load combinations of ACI 318 Appendix C are used, refer to Section D.4.5 to determine the appropriate value of ϕ .
- Sand-lightweight and all-lightweight concrete are beyond the scope of this table.

Tension Loads for Threaded Rod Anchors in Normal-Weight Concrete

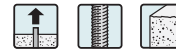

* See page 13 for an explanation of the load table icons

Rod Dia. in. (mm)	Drill Bit Dia. in.	Embed. Depth in. (mm)	Critical Edge Dist. in. (mm)	Critical Spacing Dist. in. (mm)	Tension Load Based on Bond Strength			Tension Load Based on Steel Strength			
					$f'_c \geq 2000$ psi (13.8 MPa) Concrete			F1554 Grade 36	A193 GR B7	F593 304SS	
					Ultimate lbs. (kN)	Std. Dev. lbs. (kN)	Allowable lbs. (kN)	Allowable lbs. (kN)	Allowable lbs. (kN)	Allowable lbs. (kN)	
3/8 (9.5)	1/2	3 1/2 (89)	5 1/4 (133)	14 (356)	8,777 (39.0)	324 (1.4)	2,195 (9.8)	2,105 (9.4)	4,535 (20.2)	3,630 (16.1)	
1/2 (12.7)	5/8	4 1/4 (108)	6 3/8 (162)	17 (432)	15,368 (68.4)	605 (2.7)	3,840 (17.1)	3,750 (16.7)	8,080 (35.9)	6,470 (28.8)	
5/8 (15.9)	3/4	5 (127)	7 1/2 (191)	20 (508)	22,877 (101.8)	718 (3.2)	5,720 (25.4)	5,875 (26.1)	12,660 (56.3)	10,120 (45.0)	
3/4 (19.1)	7/8	6 3/4 (171)	10 1/8 (257)	27 (686)	35,459 (157.7)	4,940 (22.0)	8,865 (39.4)	8,460 (37.6)	18,230 (81.1)	12,400 (55.2)	
7/8 (22.2)	1	7 3/4 (197)	11 3/8 (295)	31 (787)	43,596 (193.9)	1,130 (5.0)	10,900 (48.5)	11,500 (51.2)	24,785 (110.2)	16,860 (75.0)	
1 (25.4)	1 1/8	9 (229)	13 1/2 (343)	36 (914)	47,333 (210.5)	1,243 (5.5)	11,835 (52.6)	15,025 (66.8)	32,380 (144.0)	22,020 (97.9)	
1 1/8 (28.6)	1 1/4	10 3/8 (257)	15 1/4 (387)	40 1/2 (1029)	61,840 (275.1)	—	15,460 (68.8)	19,025 (84.6)	41,000 (182.4)	27,880 (124.0)	
1 1/4 (31.8)	1 3/8	11 1/4 (286)	16 3/4 (429)	45 (1143)	78,748 (350.3)	—	4,738 (21.1)	19,685 (87.6)	23,490 (104.5)	50,620 (225.2)	34,420 (153.1)

- Allowable load must be the lesser of the bond or steel strength.
- The allowable loads listed under allowable bond are based on a safety factor of 4.0.
- Refer to allowable load-adjustment factors for spacing and edge distance on pages 44 and 45.
- Refer to in-service temperature sensitivity chart for allowable load adjustment for temperature.
- Anchors are permitted to be used within fire-resistive construction, provided the anchors resist wind or seismic loads only. For use in fire-resistive construction, the anchors can also be permitted to be used to resist gravity loads, provided special consideration has been given to fire-exposure conditions.
- Anchors are not permitted to resist tension forces in overhead or wall installations unless proper consideration is given to fire-exposure and elevated-temperature conditions.

ET-HP™ (formerly ET) Anchoring Adhesive

Epoxy Adhesives

Shear Loads for Threaded Rod Anchors in Normal-Weight Concrete

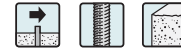

* See page 13 for an explanation of the load table icons

Rod Dia. in. (mm)	Drill Bit Dia. in.	Embed. Depth in. (mm)	Critical Edge Dist. in. (mm)	Critical Spacing Dist. in. (mm)	Shear Load Based on Concrete Edge Distance			Shear Load Based on Steel Strength		
					f' _c ≥ 2000 psi (13.8 MPa) Concrete			F1554 Grade 36	A193 GR B7	F593 304SS
					Ultimate lbs. (kN)	Std. Dev. lbs. (kN)	Allowable lbs. (kN)	Allowable lbs. (kN)	Allowable lbs. (kN)	Allowable lbs. (kN)
3/8 (9.5)	1/2	3 1/2 (89)	5 1/4 (133)	5 1/4 (133)	7,615 (33.9)	591 (2.6)	1,905 (8.5)	1,085 (4.8)	2,340 (10.4)	1,870 (8.3)
1/2 (12.7)	5/8	4 1/4 (108)	6 3/8 (162)	6 3/8 (162)	11,273 (50.1)	1,502 (6.7)	2,820 (12.5)	1,930 (8.6)	4,160 (18.5)	3,330 (14.8)
5/8 (15.9)	3/4	5 (127)	7 1/2 (191)	7 1/2 (191)	19,559 (87.0)	1,289 (5.7)	4,890 (21.8)	3,025 (13.5)	6,520 (29.0)	5,220 (23.2)
3/4 (19.1)	7/8	6 3/4 (171)	10 1/8 (257)	10 1/8 (257)	27,696 (123.2)	2,263 (10.1)	6,925 (30.8)	4,360 (19.4)	9,390 (41.8)	6,385 (28.4)
7/8 (22.2)	1	7 3/4 (197)	11 3/8 (295)	11 3/8 (295)	—	—	6,925 (30.8)	5,925 (26.4)	12,770 (56.8)	8,685 (38.6)
1 (25.4)	1 1/8	9 (229)	13 1/2 (343)	13 1/2 (343)	53,960 (240.0)	3,821 (17.0)	13,490 (60.0)	7,740 (34.4)	16,680 (74.2)	11,345 (50.5)
1 1/8 (28.6)	1 1/4	10 1/8 (257)	15 1/4 (387)	15 1/4 (387)	59,280 (263.7)	—	14,820 (65.9)	9,800 (43.6)	21,125 (94.0)	14,365 (63.9)
1 1/4 (31.8)	1 3/8	11 1/4 (286)	16 3/8 (429)	16 3/8 (429)	64,572 (287.2)	3,503 (15.6)	16,145 (71.8)	12,100 (53.8)	26,075 (116.0)	17,730 (78.9)

1. Allowable load must be the lesser of the load based on concrete edge distance or steel strength.
2. The allowable loads based on concrete edge distance are based on a safety factor of 4.0.
3. Refer to allowable load-adjustment factors for spacing and edge distance on pages 45 and 46.
4. Refer to in-service temperature sensitivity chart for allowable load adjustment for temperature.
5. Anchors are permitted to be used within fire-resistive construction, provided the anchors resist wind or seismic loads only. For use in fire-resistive construction, the anchors can also be permitted to be used to resist gravity loads, provided special consideration has been given to fire-exposure conditions.

Tension Loads for Threaded Rod Anchors in Normal-Weight Concrete Stemwall



* See page 13 for an explanation of the load table icons

Rod Dia. in. (mm)	Drill Bit Dia. in.	Embed. Depth in. (mm)	Stemwall Width in. (mm)	Min. Edge Dist. in. (mm)	Min. End Dist. in. (mm)	Tension Load Based on Bond Strength			Tension Load Based on Steel Strength
						f' _c ≥ 2000 psi (13.8 MPa) Concrete			F1554 Grade 36
						Ultimate lbs. (kN)	Std. Dev. lbs. (kN)	Allowable lbs. (kN)	Allowable lbs. (kN)
5/8 (15.9)	3/4	9 1/2 (241.3)	6 (152.4)	1 3/4 (44.5)	5 (127.0)	10,720 (47.7)	1,559 (6.9)	2,680 (11.9)	5,875 (26.1)
5/8 (15.9)	3/4	12 (304.8)	6 (152.4)	1 3/4 (44.5)	5 (127.0)	16,150 (71.8)	260 (1.2)	4,040 (18.0)	5,875 (26.1)
7/8 (22.2)	1	12 1/2 (317.5)	8 (203.2)	1 3/4 (44.5)	5 (127.0)	17,000 (75.6)	303 (1.3)	4,250 (18.9)	11,500 (51.2)
7/8 (22.2)	1	15 1/2 (393.7)	8 (203.2)	1 3/4 (44.5)	5 (127.0)	23,340 (103.8)	762 (3.4)	5,835 (26.0)	11,500 (51.2)

1. Allowable load must be the lesser of the bond or steel strength.
2. The allowable loads listed under allowable bond are based on a safety factor of 4.0.
3. Refer to in-service temperature sensitivity chart for allowable load adjustment for temperature.
4. Anchors are permitted to be used within fire-resistive construction, provided the anchors resist wind or seismic loads only. For use in fire-resistive construction, the anchors can also be permitted to be used to resist gravity loads, provided special consideration has been given to fire-exposure conditions.

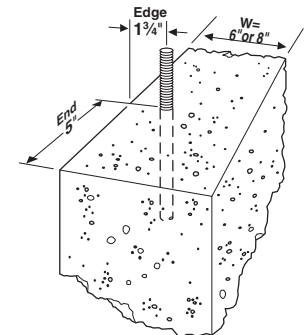

Edge and end distances for threaded rod in concrete foundation stemwall corner installation

ET-HP™ (formerly ET) Anchoring Adhesive

Epoxy Adhesives

Tension Loads for Rebar Dowels in Normal-Weight Concrete



* See page 13 for an explanation of the load table icons

Rebar Size No. (mm)	Drill Bit Dia. in.	Embed. Depth in. (mm)	Critical Edge Dist. in. (mm)	Critical Spacing Dist. in. (mm)	Tension Load Based on Bond Strength						Tension Load Based on Steel Strength
					f'c ≥ 2000 psi (13.8 MPa) Concrete			f'c ≥ 4000 psi (27.6 MPa) Concrete			ASTM A615 Grade 60 Rebar
					Ultimate lbs. (kN)	Std. Dev. lbs. (kN)	Allowable lbs. (kN)	Ultimate lbs. (kN)	Std. Dev. lbs. (kN)	Allowable lbs. (kN)	Allowable lbs. (kN)
#4 (12.7)	5/8	4 1/4 (108)	6 3/8 (162)	17 (432)	17,596 (78.3)	533 (2.4)	4,400 (19.6)	—	—	4,400 (19.6)	4,800 (21.4)
		6 (152)	9 (229)	24 (610)	—	—	—	20,250 (90.1)	263 (1.2)	5,060 (22.5)	
#5 (15.9)	3/4	5 (127)	7 1/2 (191)	20 (508)	25,427 (113.1)	1,899 (8.4)	6,355 (28.3)	—	—	6,355 (28.3)	7,440 (33.1)
		9 3/8 (238)	14 1/8 (359)	37 1/2 (953)	—	—	—	29,510 (131.3)	2,270 (10.1)	7,375 (32.8)	
#6 (19.1)	7/8	6 3/4 (171)	10 1/8 (257)	27 (686)	41,812 (186.0)	595 (2.6)	10,455 (46.5)	—	—	10,455 (46.5)	10,560 (47.0)
		11 1/4 (286)	16 3/8 (429)	45 (1143)	—	—	—	44,210 (196.7)	1,227 (5.5)	11,050 (49.2)	
#7 (22.2)	1	7 3/4 (197)	11 1/8 (295)	31 (787)	50,241 (223.5)	2,995 (13.3)	12,560 (55.9)	—	—	12,560 (55.9)	14,400 (64.1)
		13 1/8 (333)	19 3/4 (502)	52 1/2 (1334)	—	—	—	59,325 (263.9)	3,444 (15.3)	14,830 (66.0)	
#8 (25.4)	1 1/8	9 (229)	13 1/2 (343)	36 (914)	60,145 (267.5)	5,493 (24.4)	15,035 (66.9)	—	—	15,035 (66.9)	18,960 (84.3)
		12 (305)	18 (457)	48 (1219)	—	—	—	—	—	18,260 (81.2)	
		15 (381)	22 1/2 (572)	60 (1524)	—	—	—	85,970 (382.4)	17,965 (79.9)	21,490 (95.6)	
#9 (28.6)	1 1/4	9 (229)	13 1/2 (343)	36 (914)	—	—	15,035 (66.9)	—	—	15,035 (66.9)	24,000 (106.8)
		13 (330)	19 1/2 (495)	52 (1321)	—	—	—	—	—	21,310 (94.8)	
		16 7/8 (429)	25 3/8 (645)	67 1/2 (1715)	—	—	—	110,370 (491.0)	4,768 (21.2)	27,590 (122.7)	
#10 (31.8)	1 1/2	11 1/4 (286)	16 3/8 (429)	45 (1143)	70,685 (314.4)	1,112 (4.9)	17,670 (78.6)	—	—	17,670 (78.6)	30,480 (135.6)
		15 (381)	22 1/2 (572)	60 (1524)	—	—	—	—	—	23,960 (106.6)	
		18 3/4 (476)	28 1/8 (714)	75 (1905)	—	—	—	120,976 (538.1)	6,706 (29.8)	30,245 (134.5)	
#11 (34.9)	1 3/4	12 3/8 (314)	18 3/8 (473)	49 1/2 (1257)	78,422 (348.8)	4,603 (20.5)	19,605 (87.2)	—	—	19,605 (87.2)	37,440 (166.5)
		16 1/2 (419)	24 3/4 (629)	66 (1676)	—	—	—	—	—	28,605 (127.2)	
		20 3/8 (524)	31 (787)	82 1/2 (2096)	—	—	—	150,415 (669.1)	8,287 (36.9)	37,605 (167.3)	
#14 (44.5)	2	15 3/4 (400)	23 3/8 (600)	63 (1600)	91,518 (407.1)	3,797 (16.9)	22,880 (101.8)	—	—	22,880 (101.8)	54,000 (240.2)

1. Allowable load must be the lesser of the bond or steel strength.
2. The allowable loads listed under allowable bond are based on a safety factor of 4.0.
3. Refer to allowable load-adjustment factors for spacing and edge distance on pages 45 and 46.
4. Refer to in-service temperature sensitivity chart for allowable load adjustment for temperature.
5. Anchors are permitted to be used within fire-resistive construction, provided the anchors resist wind or seismic loads only. For use in fire-resistive construction, the anchors can also be permitted to be used to resist gravity loads, provided special consideration has been given to fire-exposure conditions.
6. Anchors are not permitted to resist tension forces in overhead or wall installations unless proper consideration is given to fire-exposure and elevated-temperature conditions.

ET-HP™ (formerly ET) Anchoring Adhesive

Epoxy Adhesives

Shear Loads for Rebar Dowels in Normal-Weight Concrete



* See page 13 for an explanation of the load table icons

Rebar Size No. (mm)	Drill Bit Dia. in.	Embed. Depth in. (mm)	Critical Edge Dist. in. (mm)	Critical Spacing Dist. in. (mm)	Shear Load Based on Concrete Edge Distance			Shear Load Based on Steel Strength
					f'c ≥ 2500 psi (17.2 MPa) Concrete			ASTM A615 Grade 60 Rebar
					Ultimate lbs. (kN)	Std. Dev. lbs. (kN)	Allow. lbs. (kN)	Allowable lbs. (kN)
#4 (12.7)	5/8	4 1/4 (108)	8 (203)	6 3/8 (162)	13,564 (60.3)	971 (4.3)	3,390 (15.1)	3,060 (13.6)
#5 (15.9)	3/4	5 (127)	10 (254)	7 1/2 (191)	20,914 (93.0)	3,034 (13.5)	5,230 (23.3)	4,740 (21.1)
#6 (19.1)	7/8	6 3/4 (171)	12 (305)	10 1/8 (257)	30,148 (134.1)	1,322 (5.9)	7,535 (33.5)	6,730 (29.9)
#7 (22.2)	1	7 3/4 (197)	14 (356)	11 5/8 (295)	39,838 (177.2)	1,854 (8.2)	9,960 (44.3)	9,180 (40.8)
#8 (25.4)	1 1/8	9 (229)	16 (406)	13 1/2 (343)	53,090 (236.2)	3,562 (15.8)	13,270 (59.0)	12,085 (53.8)
#9 (28.7)	1 1/4	10 3/8 (257)	18 (457)	15 1/4 (387)	63,818 (148.7)	3,671 (16.3)	15,955 (71.0)	15,300 (68.1)
#10 (32.3)	1 1/2	11 3/4 (286)	20 (508)	16 3/8 (429)	82,782 (368.2)	2,245 (10.0)	20,695 (92.1)	19,430 (86.4)
#11 (35.8)	1 5/8	12 3/8 (314)	22 (559)	18 3/8 (473)	96,056 (427.3)	3,671 (16.3)	24,015 (106.8)	23,865 (106.2)
#14 (43.0)	2	12 3/8 (314)	22 (559)	18 3/8 (473)	—	—	24,015 (106.8)	34,425 (153.1)

1. Allowable load must be the lesser of the load based on concrete edge distance or steel strength.
2. The allowable loads based on concrete edge distance are based on a safety factor of 4.0.
3. Refer to allowable load-adjustment factors for spacing and edge distance on pages 45 and 46.
4. Refer to in-service temperature sensitivity chart for allowable load adjustment for temperature.
5. Anchors are permitted to be used within fire-resistive construction, provided the anchors resist wind or seismic loads only. For use in fire-resistive construction, the anchors can also be permitted to be used to resist gravity loads, provided special consideration has been given to fire-exposure conditions.

Tension and Shear Loads for Threaded Rod Anchors in 6 and 8-inch Normal-Weight Grout-Filled CMU

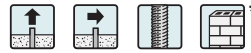

Rod Dia. in. (mm)	Drill Bit Dia. in.	Embed. Depth ^a in. (mm)	Min. Edge Dist. in. (mm)	Min. End Dist. in. (mm)	Min. Spacing Dist. in. (mm)	6 and 8-inch Grout-Filled CMU Allowable Loads Based on CMU Strength			
						Tension		Shear	
						Ultimate lbs. (kN)	Allowable lbs. (kN)	Ultimate lbs. (kN)	Allowable lbs. (kN)
Anchor Installed in Face Shell (See Figure 1)									
3/8 (9.5)	7/16	3 1/2 (89)	12 (305)	4 (102)	14 (356)	6,489 (28.9)	1,300 (5.8)	5,231 (23.3)	1,045 (4.6)
			12 (305)	12 (305)	14 (356)	7,247 (32.2)	1,450 (6.4)	6,738 (30.0)	1,350 (6.0)
1/2 (12.7)	9/16	4 1/4 (108)	12 (305)	4 (102)	17 (432)	8,646 (38.5)	1,730 (7.7)	5,705 (25.4)	1,140 (5.1)
			12 (305)	12 (305)	17 (432)	8,975 (39.9)	1,795 (8.0)	10,879 (48.4)	2,175 (9.7)
5/8 (15.9)	3/4	4 3/4 (121)	12 (305)	4 (102)	19 (483)	10,213 (45.4)	2,045 (9.1)	5,973 (26.6)	1,195 (5.3)
			12 (305)	12 (305)	19 (483)	11,290 (50.2)	2,260 (10.1)	13,027 (57.9)	2,605 (11.6)
		6 (152)	4 (102)	4 5/8 (117)	24 (610)	4,905 (21.8)	980 (4.4)	4,766 (21.2)	955 (4.2)
3/4 (19.1)	7/8	6 3/4 (171)	12 (305)	4 (102)	27 (686)	11,976 (53.3)	2,395 (10.7)	—	—
			12 (305)	12 (305)	27 (686)	—	—	19,141 (85.1)	3,830 (17.0)
Anchor Installed in Mortar "T" Joint (See Figure 2)									
3/8 (9.5)	7/16	3 1/2 (89)	8 (203)	8 (203)	14 (356)	7,646 (34.0)	1,530 (6.8)	5,507 (24.5)	1,100 (4.9)
1/2 (12.7)	9/16	4 1/4 (108)	8 (203)	8 (203)	17 (432)	9,529 (42.4)	1,905 (8.5)	8,003 (35.6)	1,600 (7.1)
5/8 (15.9)	3/4	4 3/4 (121)	8 (203)	8 (203)	19 (483)	9,955 (44.3)	1,990 (8.9)	9,529 (42.4)	1,905 (8.5)
3/4 (19.1)	7/8	6 3/4 (171)	16 (406)	8 (203)	27 (686)	—	—	7,238 (32.2)	1,450 (6.4)
Anchor Installed in Cell Opening (Top of Wall) (See Figure 3)									
5/8 (15.9)	3/4	6 (152)	4 (102)	4 3/8 (117)	24 (610)	6,721 (29.9)	1,345 (6.0)	4,833 (21.5)	965 (4.3)
3/4 (19.1)	7/8	6 (152)	4 (102)	4 3/8 (117)	24 (610)	—	1,345 (6.0)	—	965 (4.3)

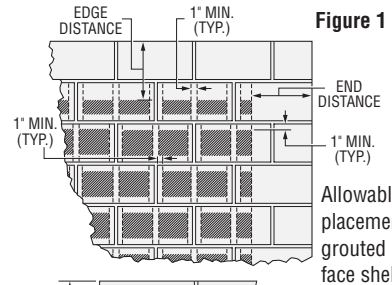

Figure 1

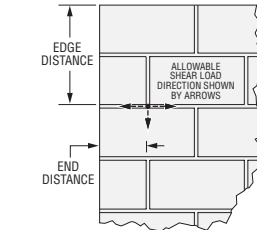

Figure 2

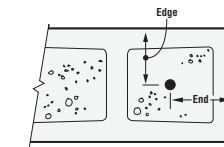

Figure 3

1. Threaded rods must comply with ASTM F1554 Grade 36 minimum.
2. Values for 6- and 8-inch wide concrete masonry units (CMU) with a minimum specified compressive strength of masonry, f'm, at 28 days is 1500 psi.
3. Embedment depth is measured from the outside face of the concrete masonry unit for installations through a face shell.
4. Allowable loads may not be increased for short-term loading due to wind or seismic forces.
5. Refer to in-service temperature sensitivity chart for allowable load adjustment for temperature.
6. The tabulated allowable loads are based on a safety factor of 5.0 for installations under the IBC and IRC.
7. Anchors must be spaced a minimum distance of four times the anchor embedment.
8. For embedment depths of 6 3/4", 8-inch-wide normal-weight grout-filled CMU block must be used.

ET-HP™ (formerly ET) Anchoring Adhesive

Epoxy Adhesives

Tension and Shear Loads for Threaded Rod Anchors in Lightweight, Medium-Weight and Normal-Weight Hollow CMU

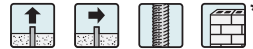

* See page 13 for an explanation of the load table icons

Figure 1

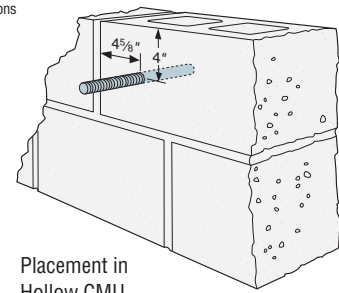

Placement in Hollow CMU

Rod Dia. in. (mm)	Drill Bit Dia. (in.)	Embed. Depth in. (mm)	Min. Edge Dist. in. (mm)	Min. End Dist. in. (mm)	6 and 8-inch Hollow CMU Allowable Loads Based on CMU Strength			
					Tension		Shear	
					Ultimate lbs. (kN)	Allowable lbs. (kN)	Ultimate lbs. (kN)	Allowable lbs. (kN)
Anchor Installed in Face Shell w/ETS Screen Tube (See Figure 1)								
1/2 (12.7)	1 1/16	3 (76.2)	4 (101.6)	4 5/8 (117.5)	1,400 (6.2)	280 (1.2)	1,326 (5.9)	265 (1.2)
3/4 (19.1)	1	3 (76.2)	4 (101.6)	4 5/8 (117.5)	—	280 (1.2)	—	265 (1.2)

1. Threaded rods must comply with ASTM F1554 Grade 36 minimum.
2. Values for 6- and 8-inch wide concrete masonry units (CMU) with a minimum specified compressive strength of masonry, f'_m , at 28 days is 1500 psi.
3. Embedment depth is measured from the outside face of the concrete masonry unit for installations through a face shell.
4. Allowable loads may not be increased for short-term loading due to wind or seismic forces.
5. Refer to in-service temperature sensitivity chart for allowable load adjustment for temperature.
6. The tabulated allowable loads are based on a safety factor of 5.0 for installations under the IBC and IRC.
7. Anchors must be spaced a minimum distance of four times the anchor embedment.
8. Set drill to rotation-only mode when drilling into hollow CMU.

Configuration A (Shear)

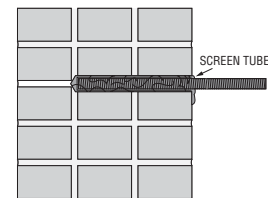

Tension and Shear Loads for Installations in Unreinforced Brick Masonry Walls Minimum URM Wall Thickness is 13" (3 wythes thick)



Rod Dia. in. (mm)	Drill Bit Dia. in.	Embed. Depth in. (mm)	Min. Edge/End Dist. in. (mm)	Min. Vertical Spacing Dist. in. (mm)	Min. Horiz. Spacing Dist. in. (mm)	Tension Load Based on URM Strength	Shear Load Based on URM Strength
						Minimum Net Mortar Strength = 50 psi	Minimum Net Mortar Strength = 50 psi
						Allowable lbs. (kN)	Allowable lbs. (kN)
Configuration A (Simpson ETS or ETSP Screen Tube Required)							
3/4 (19.1)	1	8 (203)	24 (610)	18 (457)	18 (457)	—	1,000 (4.4)
Configuration B (Simpson ETS or ETSP Screen Tube Required)							
3/4 (19.1)	1	13 (330)	16 (406)	18 (457)	24 (610)	1,200 (5.3)	1,000 (4.4)
Configuration C (Simpson ETS Screen Tube and AST Steel Sleeve Required)							
5/8 (15.9)	1	**	24 (610)	18 (457)	18 (457)	1,200 (5.3)	750 (3.3)

1. Threaded rods must comply with ASTM F1554 Grade 36 minimum.
2. All holes are drilled with a 1" diameter carbide-tipped drill bit with the drill set in the rotation-only mode.
3. The unreinforced brick walls must have a minimum thickness of 13 inches (three wythes of brick).
4. The allowable load is applicable only where in-place shear tests indicate minimum net mortar strength of 50 psi.
5. The allowable load for Configuration B and C anchors subjected to a combined tension and shear load is determined by assuming a straight-line relationship between allowable tension and shear.
6. The anchors installed in unreinforced brick walls are limited to resisting seismic or wind forces only.
7. Configuration A has a straight threaded rod or rebar embedded 8 inches into the wall with a 3/8" diameter by 8-inch long screen tube (part # ETS758 or ETS758P). This configuration is designed to resist shear loads only.
8. Configuration B has a 3/4" threaded rod bent and installed at a 22.5-degree angle and installed 13 inches into the wall, to within 1-inch (maximum) of the exterior wall surface. This configuration is designed to resist tension and shear loads. The pre-bent threaded rod is installed with a 3/8" diameter by 13-inch long screen tube (part # ETS7513 or ETS7513P).
9. Configuration C is designed to resist tension and shear forces. It consists of a 5/8" diameter, ASTM F1554 Grade 36 threaded rod and an 8" long sleeve (part # AST800) and a 3/8" diameter by 8-inch long screen tube (part # ETS758). The steel sleeve has a plastic plug in one end. A 6" by 6" by 3/8" thick ASTM A 36 steel plate is located on the back face of the wall.
10. Special inspection requirements are determined by local jurisdiction and must be confirmed by the local building official.
11. Refer to in-service temperature sensitivity chart for allowable load adjustment for temperature.

Configuration B (Tension & Shear)

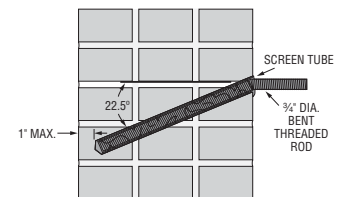

Configuration C (Tension & Shear)

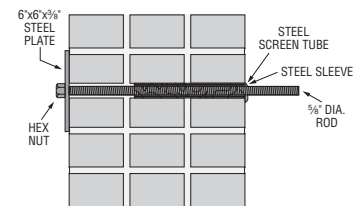

Installation Instructions for Configuration C:

1. Drill hole perpendicular to the wall to a depth of 8" with a 1" diameter carbide-tipped drill bit (rotation only mode).
2. Clean hole with oil-free compressed air and a nylon brush.
3. Fill 8" steel screen tube with mixed adhesive and insert into hole.
4. Insert steel sleeve slowly into screen tube (adhesive will displace).
5. Allow adhesive to cure (see cure schedule).
6. Drill through plastic plug in (inside) end of steel sleeve with 5/8" bit.
7. Drill completely through the wall with 5/8" carbide tipped concrete drill bit (rotation mode only).
8. Insert 5/8" rod through hole and attach metal plate and nut.

ET-HP™ (formerly ET) Technical Information

Load-Adjustment Factors for ET-HP™ Adhesive in Normal-Weight Concrete: Edge Distance, Tension and Shear Loads

How to use these charts:

- The following tables are for reduced edge distance.
- Locate the anchor size to be used for either a tension and/or shear application.
- Locate the embedment (E) at which the anchor is to be installed.
- Locate the edge distance (C_{act}) at which the anchor is to be installed.
- The load-adjustment factor (f_c) is the intersection of the row and column.
- Multiply the allowable load by the applicable load-adjustment factor.
- Reduction factors for multiple edges are multiplied together.
- Adjustment factors do not apply to allowable steel strength values.
- Adjustment factors are to be applied to allowable tension load based on bond strength values or allowable Shear Load Based on Concrete Edge Distance values only.

Edge Distance Tension (f_c)

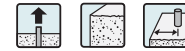

* See page 13 for an explanation of the load table icons

Edge Dist. (in.)	Dia. Rebar	#4		#5		#6		#7		#8		#9		#10		#11		#14		
		E	C _{cr}	C _{min}	f _{cmin}	E	C _{cr}	C _{min}	f _{cmin}	E	C _{cr}	C _{min}	f _{cmin}	E	C _{cr}	C _{min}	f _{cmin}	E	C _{cr}	C _{min}
		3½	4¼	6	5	9⅝	6¾	11¼	7¾	13⅜	9	15	9	16⅞	10⅞	11¼	18¾	12⅞	20⅝	15¾
		5¼	6⅝	9	7½	14⅝	10⅞	16⅞	11⅞	19¼	13½	22½	13½	25⅞	15¼	16⅞	28⅞	18⅞	31	23⅞
		1¼	1¼	1¼	1¼	1¼	1¼	1¼	1¼	1¼	1¼	1¼	2¼	2¼	2¼	2¼	2¼	2¼	2¼	2¼
		0.50	0.50	0.59	0.50	0.64	0.50	0.57	0.50	0.52	0.50	0.47	0.50	0.47	0.58	0.58	0.51	0.58	0.51	0.58
1¾		0.50	0.50	0.59	0.50	0.64	0.50	0.57	0.50	0.52	0.50	0.47								
2¾		0.64	0.61	0.65	0.59	0.67	0.56	0.60	0.55	0.54	0.50		0.50	0.47	0.58	0.58	0.51	0.58	0.51	0.58
3		0.68	0.64	0.66	0.61	0.68	0.57	0.61	0.56	0.55	0.50	0.51	0.48	0.59	0.59	0.51	0.59	0.51	0.59	
4		0.82	0.74	0.72	0.70	0.71	0.63	0.63	0.61	0.58	0.60	0.53	0.56	0.50	0.62	0.62	0.53	0.61	0.53	0.61
5		0.96	0.85	0.77	0.78	0.73	0.69	0.66	0.66	0.61	0.64	0.55	0.60	0.52	0.66	0.65	0.55	0.64	0.55	0.63
6		1.00	0.96	0.83	0.87	0.76	0.75	0.69	0.72	0.66	0.68	0.58	0.65	0.55	0.69	0.68	0.57	0.67	0.57	0.65
7			1.00	0.89	0.96	0.79	0.81	0.72	0.77	0.63	0.60	0.70	0.57	0.72	0.71	0.59	0.69	0.58	0.67	0.67
8				0.94	1.00	0.82	0.87	0.75	0.82	0.69	0.77	0.63	0.74	0.59	0.76	0.74	0.61	0.72	0.60	0.69
9				1.00		0.85	0.93	0.78	0.87	0.71	0.81	0.66	0.79	0.62	0.79	0.77	0.63	0.75	0.62	0.71
10						0.88	0.99	0.80	0.92	0.74	0.85	0.68	0.84	0.64	0.82	0.80	0.65	0.77	0.64	0.73
12						0.94	1.00	0.86	1.00	0.79	0.94	0.73	0.93	0.69	0.89	0.86	0.69	0.82	0.67	0.77
14					1.00			0.92		0.85	1.00	0.78	1.00	0.73	0.96	0.91	0.73	0.88	0.71	0.81
16								0.98		0.90		0.83		0.78	1.00	0.97	0.77	0.93	0.74	0.85
18							1.00			0.95		0.89		0.83		1.00	0.80	0.98	0.77	0.89
20									1.00		0.94		0.87			0.84	1.00	0.81	0.93	
22											0.99		0.92			0.88		0.84	0.97	
24											1.00		0.97			0.92		0.88	1.00	
26														1.00		0.96		0.91		
28																1.00		0.95		
30																		0.98		
32																		1.00		

See notes below.

Edge Distance Shear (f_c)

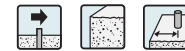

* See page 13 for an explanation of the load table icons

Edge Dist. (in.)	Dia. Rebar	#4		#5		#6		#7		#8		#9		#10		#11		#14		
		E	C _{cr}	C _{min}	f _{cmin}	E	C _{cr}	C _{min}	f _{cmin}	E	C _{cr}	C _{min}	f _{cmin}	E	C _{cr}	C _{min}	f _{cmin}	E	C _{cr}	C _{min}
		3½	4¼	4	5	6¾	6¾	7¾	7¾	9	9	10⅞	10⅞	11¼	11¼	12⅞	12⅞	12⅞		
		5¼	6⅝	8	7½	10	10⅞	12	11⅞	14	13½	16	18	15¼	16⅞	20	22	22		
		1¼	1¼	1¼	1¼	1¼	1¼	1¼	1¼	1¼	1¼	2¼	2¼	2¼	2¼	2¼	2¼	2¼		
		0.29	0.20	0.16	0.13	0.10	0.13	0.10	0.13	0.09	0.08	0.08	0.08	0.14	0.14	0.14	0.14	0.14		
1¾		0.29	0.20	0.16	0.13	0.10	0.13	0.10	0.13	0.09	0.08	0.08								
2¾		0.49	0.37	0.29	0.28	0.21	0.23	0.19	0.22	0.16	0.16	0.14	0.08	0.14	0.14	0.14	0.14	0.14	0.14	0.14
3		0.54	0.42	0.33	0.32	0.24	0.26	0.21	0.24	0.18	0.18	0.16	0.10	0.16	0.16	0.15	0.15	0.15	0.15	0.15
4		0.75	0.59	0.46	0.47	0.35	0.36	0.30	0.33	0.26	0.26	0.23	0.16	0.23	0.22	0.20	0.20	0.20	0.20	0.20
5		0.95	0.76	0.60	0.62	0.45	0.47	0.39	0.42	0.33	0.33	0.29	0.22	0.29	0.28	0.25	0.24	0.24	0.24	0.24
6		1.00	0.94	0.73	0.77	0.56	0.57	0.47	0.50	0.41	0.41	0.35	0.28	0.36	0.34	0.30	0.29	0.29	0.29	0.29
7			1.00	0.87	0.92	0.67	0.68	0.56	0.59	0.48	0.49	0.42	0.34	0.43	0.40	0.35	0.33	0.33	0.33	0.33
8				1.00	1.00	0.78	0.78	0.65	0.68	0.55	0.57	0.48	0.40	0.50	0.46	0.40	0.37	0.37	0.37	0.37
9						0.89	0.88	0.74	0.77	0.63	0.65	0.55	0.46	0.57	0.52	0.45	0.42	0.42	0.42	0.42
10						1.00	0.99	0.82	0.86	0.70	0.73	0.61	0.52	0.64	0.58	0.50	0.46	0.46	0.46	0.46
11							1.00	0.91	0.94	0.78	0.80	0.68	0.58	0.71	0.64	0.55	0.51	0.51	0.51	0.51
12								1.00	1.00	0.85	0.88	0.74	0.64	0.78	0.70	0.60	0.55	0.55	0.55	0.55
13										0.93	0.96	0.81	0.70	0.85	0.76	0.65	0.60	0.60	0.60	0.60
14										1.00	1.00	0.87	0.76	0.91	0.82	0.70	0.64	0.64	0.64	0.64
15												0.94	0.82	0.98	0.89	0.75	0.69	0.69	0.69	0.69
16												1.00	0.88	1.00	0.95	0.80	0.73	0.73	0.73	0.73
18													1.00		1.00	0.90	0.82	0.82	0.82	0.82
20																1.00	0.91	0.91	0.91	0.91
22																	1.00	1.00	1.00	1.00

- E = Embedment depth (inches).
- C_{act} = actual edge distance at which anchor is installed (inches).
- C_{cr} = critical edge distance for 100% load (inches).
- C_{min} = minimum edge distance for reduced load (inches).
- f_c = adjustment factor for allowable load at actual edge distance.
- f_{cr} = adjustment factor for allowable load at critical edge distance. f_{cr} is always = 1.00.
- f_{cmin} = adjustment factor for allowable load at minimum edge distance.
- f_c = f_{cmin} + [(1 - f_{cmin}) (C_{act} - C_{min}) / (C_{cr} - C_{min})].

ET-HP™ (formerly ET) Technical Information

Epoxy Adhesives

Load-Adjustment Factors for ET-HP™ Adhesive in Normal-Weight Concrete: Spacing, Tension and Shear Loads

How to use these charts:

1. The following tables are for reduced spacing.
2. Locate the anchor size to be used for either a tension and/or shear load application.
3. Locate the embedment (E) at which the anchor is to be installed.
4. Locate the spacing (S_{act}) at which the anchor is to be installed.
5. The load-adjustment factor (f_s) is the intersection of the row and column.
6. Multiply the allowable load by the applicable load-adjustment factor.
7. Reduction factors for multiple spacings are multiplied together.
8. Adjustment factors do not apply to allowable steel strength values.
9. Adjustment factors are to be applied to allowable Tension Load Based on Bond Strength values or allowable Shear Load Based on Concrete Edge Distance values only.

Spacing Tension (f_s)



* See page 13 for an explanation of the load table icons

S _{act} (in.)	Dia.	3/8	1/2	5/8	3/4	7/8	1	1 1/8	1 1/4	1 3/8	1 1/2	1 5/8	1 3/4	1 7/8	2				
	Rebar	#4	#5	#6	#7	#8	#9	#10	#11	#14									
E	3 1/2	4 1/4	6	5	9 3/8	6 3/4	11 1/4	7 3/4	13 3/8	9	15	9	16 7/8	10 1/8	11 1/4	18 3/4	12 3/8	20 5/8	15 3/4
S _{cr}	14	17	24	20	37 1/2	27	45	31	52 1/2	36	60	36	67 1/2	40 1/2	45	75	49 1/2	82 1/2	63
S _{min}	1 1/4	2 1/8	3	2 1/2	4 3/4	3 3/8	5 3/8	3 3/8	6 3/8	4 1/2	7 1/2	4 1/2	8 1/2	5 3/8	5 3/8	9 3/8	6 3/4	10 3/8	7 3/8
f _{smin}	0.89	0.89	0.89	0.89	0.89	0.89	0.89	0.89	0.89	0.89	0.89	0.89	0.89	0.89	0.89	0.89	0.89	0.89	0.89
1 3/4		0.89																	
2		0.89																	
4		0.91	0.90	0.90	0.90		0.89		0.89										
6		0.93	0.92	0.91	0.91	0.89	0.90	0.89	0.90		0.90		0.90		0.89	0.89			
8		0.95	0.93	0.92	0.92	0.90	0.91	0.90	0.91	0.89	0.90	0.89	0.90		0.90	0.90		0.89	0.89
10		0.96	0.95	0.93	0.94	0.91	0.92	0.90	0.91	0.90	0.91	0.89	0.91	0.89	0.91	0.90	0.89	0.90	0.89
12		0.98	0.96	0.94	0.95	0.91	0.93	0.91	0.92	0.90	0.92	0.90	0.92	0.90	0.91	0.91	0.89	0.90	0.89
14		1.00	0.98	0.95	0.96	0.92	0.94	0.91	0.93	0.91	0.92	0.90	0.92	0.90	0.92	0.91	0.90	0.91	0.90
16			0.99	0.96	0.97	0.93	0.95	0.92	0.94	0.91	0.93	0.91	0.93	0.90	0.92	0.92	0.90	0.91	0.90
18			1.00	0.97	0.99	0.93	0.96	0.92	0.95	0.92	0.94	0.91	0.94	0.91	0.93	0.92	0.90	0.92	0.90
20				0.98	1.00	0.94	0.97	0.93	0.96	0.92	0.94	0.92	0.94	0.91	0.94	0.93	0.91	0.92	0.90
24				1.00		0.95	0.99	0.94	0.97	0.93	0.96	0.92	0.96	0.92	0.95	0.94	0.91	0.94	0.91
28					0.97	1.00	0.95	0.99	0.94	0.97	0.93	0.97	0.93	0.96	0.95	0.92	0.95	0.92	0.93
32					0.98		0.96	1.00	0.95	0.99	0.94	0.99	0.93	0.97	0.96	0.93	0.96	0.92	0.94
36					0.99		0.97		0.96	1.00	0.95	1.00	0.94	0.99	0.97	0.93	0.97	0.93	0.95
40						1.00		0.99		0.97		0.96		0.95	1.00	0.99	0.94	0.98	0.94
45							1.00		0.98		0.97		0.96		1.00	0.95	0.99	0.94	0.96
50								0.99		0.98		0.97			0.96	1.00	0.95	0.97	
55									1.00		0.99		0.98			0.97	0.96	0.98	
60										1.00		0.99				0.97	0.97	0.99	
65													1.00			0.98	0.97	1.00	
70																0.99	0.98		
75																	1.00	0.99	
82 1/2																		1.00	

See Notes Below

Spacing Shear (f_s)

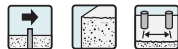

* See page 13 for an explanation of the load table icons

S _{act} (in.)	Dia.	3/8	1/2	5/8	3/4	7/8	1	1 1/8	1 1/4	1 3/8	1 1/2
	Rebar	#4	#5	#6	#7	#8	#9	#10	#11	#14	
E	3 1/2	4 1/4	5	6 3/4	7 3/4	9	10 1/8	11 1/4	12 3/8	12 3/8	
S _{cr}	5 1/4	6 3/8	7 1/2	10 1/8	11 5/8	13 1/2	15 1/4	16 3/8	18 3/8	18 3/8	
S _{min}	1 1/4	2 1/8	2 1/2	3 3/8	3 3/8	4 1/2	5 1/8	5 3/8	6 1/4	6 1/4	
f _{smin}	0.83	0.83	0.83	0.83	0.83	0.83	0.83	0.83	0.83	0.83	
1 3/4		0.83									
2		0.84									
3		0.89	0.87	0.85							
4		0.94	0.91	0.88	0.85	0.83					
5		0.99	0.95	0.92	0.87	0.85	0.84				
6		1.00	0.99	0.95	0.90	0.88	0.86	0.84	0.84		
7			1.00	0.98	0.92	0.90	0.88	0.86	0.85	0.84	
8				1.00	0.95	0.92	0.90	0.88	0.87	0.85	
9					0.97	0.94	0.92	0.90	0.88	0.87	
10					1.00	0.96	0.93	0.91	0.90	0.88	
12						1.00	0.97	0.95	0.93	0.91	
14							1.00	0.98	0.96	0.94	
16								1.00	0.99	0.96	
18									1.00	0.99	
20										1.00	

1. E = Embedment depth (inches).
2. S_{act} = actual spacing distance at which anchors are installed (inches).
3. S_{cr} = critical spacing distance for 100% load (inches).
4. S_{min} = minimum spacing distance for reduced load (inches).
5. f_s = adjustment factor for allowable load at actual spacing distance.
6. f_{s cr} = adjustment factor for allowable load at critical spacing distance. f_{s cr} is always = 1.00.
7. f_{s min} = adjustment factor for allowable load at minimum spacing distance.
8. f_s = f_{s min} + [(1 - f_{s min}) (S_{act} - S_{min}) / (S_{cr} - S_{min})].

EDOT Epoxy Anchoring Adhesive

Epoxy Adhesives

EDOT adhesive is formulated to provide an economical and high-strength solution for transportation projects.* It is a two component, high-solids epoxy-based system that is a non-shrink anchor grouting material. Resin and hardener are dispensed and mixed simultaneously through the static mixing nozzle. EDOT meets the requirements of ASTM C-881 and AASHTO M235 specifications for Type I, II, IV and V, Grade 3, Class C.

*Visit www.strongtie.com/dot for specific state DOT approvals.

- USES:**
- Threaded rod anchoring
 - Rebar doweling

APPLICATION: Surfaces to receive epoxy must be clean. The base material temperature must be 40°F or above at the time of installation. For best results, material should be 70°F–80°F at the time of application. Cartridges should not be immersed in water to facilitate warming. To warm cold material, the cartridges should be stored in warm, uniformly heated area or storage container for a sufficient time to allow epoxy to warm completely. Mixed material in nozzle can harden in 5-7 minutes at a temperature of 40°F or above.

INSTALLATION: See pages 70–71.

SHELF LIFE: 24 months from date of manufacture in unopened container.

STORAGE CONDITIONS: For best results, store between 45°F–90°F. To store partially used cartridges, leave hardened nozzle in place. To re-use, attach new nozzle.

COLOR: Resin – white, hardener – brown

When properly mixed, EDOT adhesive will be a uniform and consistent tan color.

CLEAN UP: Uncured material – Wipe up with cotton cloths. If desired, scrub area with abrasive, waterbased cleaner and flush with water. If approved, solvents such as ketones (MEK, acetone, etc.), lacquer thinner, or adhesive remover can be used. **DO NOT USE SOLVENTS TO CLEAN ADHESIVE FROM SKIN.** Take appropriate precautions when handling flammable solvents. Solvents may damage surfaces to which they are applied. Cured material – Chip or grind off surface.

TEST CRITERIA: Anchors installed with EDOT adhesive have been tested in accordance with ASTM E488 and ASTM E1512.

PROPERTY	TEST METHOD	RESULTS
Consistency (77°F)	ASTM C-881	Non-sag/ thixotropic paste
Heat deflection	ASTM D-648	129°F (54°C)
Bond strength (moist cure)	ASTM C-882	3054 psi (2 days) 3425 psi (14 days)
Water absorption	ASTM D-570	0.04% (24 hours)
Compressive yield strength	ASTM D-695	10,053 psi (7 days)
Compressive modulus	ASTM D-695	393,000 psi (7 days)
Gel time	ASTM C-881	46 min. @ 73 °F (23°C) 32 min. @ 90 °F (32°C)

CHEMICAL RESISTANCE Very good to excellent against distilled water, dilute inorganic acids and alkalis. Fair to good against organic acids and alkalis, and many organic solvents. Poor against ketones. For more detailed information, visit www.strongtie.com or contact Simpson Strong-Tie.

SUGGESTED SPECIFICATIONS: Anchoring adhesives shall be a two-component high solids epoxy based system dispensed through a static mixing nozzle supplied by the manufacturer. Epoxy shall meet the minimum requirements of ASTM C881 and AASHTO M235 specification for Type I, II, IV, and V, Grade 3, Class C, and must develop a minimum 10,000 psi compressive yield strength after 7 day cure. Epoxy must have a heat deflection temperature of a minimum 125°F (52°C). Adhesive shall be EDOT adhesive from Simpson Strong-Tie, Pleasanton, CA. Anchors shall be installed per Simpson Strong-Tie instructions for EDOT adhesive.

ACCESSORIES: See pages 72–77 for information on dispensing tools, mixing nozzles and other accessories.



EDOT22



EDOT56



EDOT 1 gallon kit



EDOT 10 gallon kit

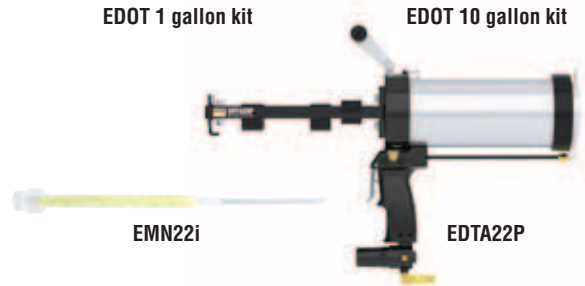

EMN22i

EDTA22P

EDOT Package Systems

Model No.	Capacity (cubic inches)	Package Type	Carton Quantity	Dispensing Tool(s)	Mixing Nozzle
EDOT22	22 ounces (39.7)	Cartridge, Side-by-side	10	EDT22S, EDTA22P, EDT22CKT	EMN22i
EDOT56	56 ounces (101.1)	Cartridge, Side-by-side	6	EDTA56P	EMN22i or EMN50
EDOT1KT	1 gallon kit (231)	(2) ½ gal pails	1 kit	Metering pump	EMN37A
EDOT10KT	10 gallon kit (2,310)	(2) 5 gallon pails	1 kit	Metering pump	EMN37A
EDOT100KT	100 gallon kit (23,100)	(2) 50 gallon drums	1 kit	Metering pump	EMN37A

1. Cartridge and bulk Estimation Guides are available on pages 48–51.
2. Detailed information on dispensing tools, mixing nozzles and other adhesive accessories is available on pages 72–77.
3. Use only appropriate Simpson Strong-Tie® mixing nozzle in accordance with Simpson Strong-Tie instructions. Modification or improper use of mixing nozzle may impair epoxy performance.
4. Metering pumps offered by third-party manufacturers.

Cure Schedule

Base Material Temperature	Cure Time	
	°F	°C
40	4	72 hrs
60	16	24 hrs
80	27	24 hrs
100	38	24 hrs

In-Service Temperature Sensitivity

Base Material Temperature	Percent of Allowable load
40	100%
70	100%
110	100%
135	85%

Pot Life for 1 gallon mixed

Adhesive Temperature	Pot Life time (min)	
	°F	°C
60	16	60
70	21	35
80	27	25
90	32	15
100	38	10

Estimating Guides for SET-XP, SET, ET-HP and EDOT Adhesives

Epoxy Adhesives

Estimating Guide for 8.5 oz. Cartridge using Threaded Rod - Installations per Cartridge

Rod Dia. (in.)	Drill Bit Dia. (in.)	THREADED ROD IN SOLID BASE MATERIAL HOLE DEPTH (inches)																		
		2	3	4	5	6	7	8	9	10	11	12	13	14	15	16	17	18	19	20
3/8	7/16	67	45	34	27	22	19	17	15	13	12	11	10	10	9	8	8	7	7	7
3/8	1/2	42	28	21	17	14	12	11	9	8	8	7	7	6	6	5	5	5	4	4
1/2	9/16	49	32	24	19	16	14	12	11	10	9	8	7	7	6	6	6	5	5	5
1/2	5/8	31	20	15	12	10	9	8	7	6	6	5	5	4	4	4	4	3	3	3
5/8	3/4	24	16	12	10	8	7	6	5	5	4	4	4	3	3	3	3	3	3	2.4
5/8	7/8	14	9	7	5	5	4	3	3	3	2.5	2.3	2.1	2.0	1.8	1.7	1.6	1.5	1.4	1.4
3/4	7/8	19	13	10	8	6	6	5	4	4	4	3	3	3	3	2.4	2.3	2.1	2.0	1.9
3/4	1	12	8	6	5	4	3	3	3	2.3	2.1	1.9	1.8	1.7	1.5	1.4	1.4	1.3	1.2	1.2
7/8	1	16	11	8	6	5	5	4	4	3	3	3	2.5	2.3	2.2	2.0	1.9	1.8	1.7	1.6
7/8	1 1/8	10	6	5	4	3	3	2.4	2.2	1.9	1.8	1.6	1.5	1.4	1.3	1.2	1.1	1.1	1.0	1.0
1	1 1/8	13	9	7	5	4	4	3	3	3	2.4	2.2	2.1	1.9	1.8	1.7	1.6	1.5	1.4	1.3
1	1 1/4	8	6	4	3	3	2.4	2.1	1.9	1.7	1.5	1.4	1.3	1.2	1.1	1.1	1.0	0.9	0.9	0.8
1 1/8	1 1/4	12	8	6	5	4	3	3	3	2.3	2.1	1.9	1.8	1.6	1.5	1.4	1.4	1.3	1.2	1.2
1 1/8	1 3/8	7	5	4	3	2.5	2.1	1.9	1.6	1.5	1.3	1.2	1.1	1.1	1.0	0.9	0.9	0.8	0.8	0.7
1 1/4	1 3/8	10	7	5	4	3	3	3	2.3	2.1	1.9	1.7	1.6	1.5	1.4	1.3	1.2	1.2	1.1	1.0
1 1/4	1 1/2	7	4	3	3	2.2	1.9	1.7	1.5	1.3	1.2	1.1	1.0	1.0	0.9	0.8	0.8	0.7	0.7	0.7

Estimating Guide for 8.5 oz. Cartridge using Rebar - Installations per Cartridge

Rebar Size (no.)	Drill Bit Dia. (in.)	REBAR IN SOLID BASE MATERIAL HOLE DEPTH (inches)																		
		2	3	4	5	6	7	8	9	10	11	12	13	14	15	16	17	18	19	20
3	7/16	90	60	45	36	30	26	22	20	18	16	15	14	13	12	11	11	10	9	9
3	1/2	50	34	25	20	17	14	13	11	10	9	8	8	7	7	6	6	5	5	5
4	9/16	74	49	37	30	25	21	18	16	15	13	12	11	11	10	9	9	8	8	7
4	5/8	39	26	20	16	13	11	10	9	8	7	7	6	6	5	5	5	4	4	4
5	3/4	32	21	16	13	11	9	8	7	6	6	5	5	5	4	4	4	4	3	3
5	7/8	16	11	8	6	5	5	4	4	3	3	3	2.4	2.3	2.1	2.0	1.9	1.8	1.7	1.6
6	7/8	25	17	13	10	8	7	6	6	5	5	4	4	4	3	3	3	3	3	3
6	1	13	9	7	5	4	4	3	3	3	2.5	2.2	2.1	1.9	1.8	1.7	1.6	1.5	1.4	1.3
7	1	22	15	11	9	7	6	6	5	4	4	4	3	3	3	3	3	2.4	2.3	2.2
7	1 1/8	11	8	6	5	4	3	3	3	2.3	2.1	1.9	1.8	1.6	1.5	1.4	1.4	1.3	1.2	1.1
8	1 1/8	19	13	9	8	6	5	5	4	4	3	3	3	3	3	2.4	2.2	2.1	2.0	1.9
8	1 1/4	10	7	5	4	3	3	3	2.3	2.1	1.9	1.7	1.6	1.5	1.4	1.3	1.2	1.2	1.1	1.0
9	1 1/4	17	11	8	7	6	5	4	4	3	3	3	3	2.4	2.3	2.1	2.0	1.9	1.8	1.7
9	1 3/8	9	6	5	4	3	3	2.3	2.1	1.9	1.7	1.6	1.4	1.3	1.2	1.2	1.1	1.0	1.0	0.9
10	1 1/2	9	6	5	4	3	3	2.3	2.0	1.8	1.6	1.5	1.4	1.3	1.2	1.1	1.1	1.0	0.9	0.9
10	1 3/4	4	3	2.2	1.8	1.5	1.3	1.1	1.0	0.9	0.8	0.7	0.7	0.6	0.6	0.6	0.5	0.5	0.5	0.4
11	1 5/8	9	6	4	3	3	2.5	2.2	1.9	1.7	1.6	1.4	1.3	1.2	1.2	1.1	1.0	1.0	0.9	0.9
11	1 7/8	4	3	2.1	1.7	1.4	1.2	1.1	0.9	0.9	0.8	0.7	0.7	0.6	0.6	0.5	0.5	0.5	0.4	0.4

Tables are estimations. Actual usage may vary depending on waste.

Note: Online adhesive cartridge quantity estimating tools are available by visiting www.strongtie.com

Estimating Guides for SET-XP, SET, ET-HP and EDOT Adhesives

Epoxy Adhesives

Estimating Guide for 22 oz. Cartridge using Threaded Rod – Installations per Cartridge

Rod Dia. (in.)	Drill Bit Dia. (in.)	THREADED ROD IN SOLID BASE MATERIAL																		
		HOLE DEPTH (inches)																		
		2	3	4	5	6	7	8	9	10	11	12	13	14	15	16	17	18	19	20
3/8	7/16	174	116	87	70	58	50	43	39	35	32	29	27	25	23	22	20	19	18	17
3/8	1/2	110	73	55	44	37	31	27	24	22	20	18	17	16	15	14	13	12	12	11
1/2	9/16	126	84	63	51	42	36	32	28	25	23	21	19	18	17	16	15	14	13	13
1/2	5/8	80	53	40	32	27	23	20	18	16	14	13	12	11	11	10	9	9	8	8
5/8	3/4	62	42	31	25	21	18	16	14	12	11	10	10	9	8	8	7	7	7	6
5/8	7/8	36	24	18	14	12	10	9	8	7	6	6	5	5	5	4	4	4	4	4
3/4	7/8	50	33	25	20	17	14	13	11	10	9	8	8	7	7	6	6	6	5	5
3/4	1	30	20	15	12	10	9	8	7	6	5	5	5	4	4	4	4	3	3	3
7/8	1	42	28	21	17	14	12	11	9	8	8	7	6	6	6	5	5	5	4	4
7/8	1 1/8	25	17	13	10	8	7	6	6	5	5	4	4	4	3	3	3	3	3	3
1	1 1/8	35	23	17	14	12	10	9	8	7	6	6	5	5	5	4	4	4	4	3
1	1 1/4	22	15	11	9	7	6	5	5	4	4	3	3	3	3	3	2	2	2	2
1 1/8	1 1/4	30	20	15	12	10	9	7	7	6	5	5	4	4	4	4	3	3	3	3
1 1/8	1 3/8	19	13	10	8	6	5	5	4	4	3	3	3	3	2	2	2	2	2	2
1 1/4	1 3/8	27	18	13	11	9	8	7	6	5	5	4	4	4	4	3	3	3	3	3
1 1/4	1 1/2	17	12	9	7	6	5	4	4	3	3	3	3	2	2	2	2	2	2	2

Estimating Guide for 22 oz. Cartridge using Rebar – Installations per Cartridge

Rebar Size (no.)	Drill Bit Dia. (in.)	REBAR IN SOLID BASE MATERIAL																		
		HOLE DEPTH (inches)																		
		2	3	4	5	6	7	8	9	10	11	12	13	14	15	16	17	18	19	20
3	7/16	233	155	116	93	78	67	58	52	47	42	39	36	33	31	29	27	26	25	23
3	1/2	131	87	65	52	44	37	33	29	26	24	22	20	19	17	16	15	15	14	13
4	9/16	192	128	96	77	64	55	48	43	38	35	32	30	27	26	24	23	21	20	19
4	5/8	102	68	51	41	34	29	25	23	20	18	17	16	15	14	13	12	11	11	10
5	3/4	82	55	41	33	27	23	20	18	16	15	14	13	12	11	10	10	9	9	8
5	7/8	41	27	21	16	14	12	10	9	8	7	7	6	6	5	5	5	5	4	4
6	7/8	65	44	33	26	22	19	16	15	13	12	11	10	9	9	8	8	7	7	7
6	1	35	23	17	14	12	10	9	8	7	6	6	5	5	5	4	4	4	4	3
7	1	57	38	29	23	19	16	14	13	11	10	10	9	8	8	7	7	6	6	6
7	1 1/8	30	20	15	12	10	9	7	7	6	5	5	5	4	4	4	4	3	3	3
8	1 1/8	49	33	25	20	16	14	12	11	10	9	8	8	7	7	6	6	5	5	5
8	1 1/4	27	18	13	11	9	8	7	6	5	5	4	4	4	4	3	3	3	3	3
9	1 1/4	44	29	22	18	15	13	11	10	9	8	7	7	6	6	6	5	5	5	4
9	1 3/8	24	16	12	10	8	7	6	5	5	4	4	4	3	3	3	3	3	3	2
10	1 1/2	23	16	12	9	8	7	6	5	5	4	4	4	3	3	3	3	3	2	2
10	1 3/4	12	8	6	5	4	3	3	3	2	2	2	2	2	2	1	1	1	1	1
11	1 5/8	22	15	11	9	7	6	6	5	4	4	4	3	3	3	3	3	2	2	2
11	1 7/8	11	7	6	4	4	3	3	2	2	2	2	2	2	1	1	1	1	1	1

Estimating Guide for 22 oz. Cartridge and Steel Screen Tubes – Installations per Cartridge

Rod Dia. (in.)	Drill Bit Dia. (in.)	THREADED ROD INSERTED IN SCREEN TUBE																		
		HOLE DEPTH (inches)																		
		3 1/2	4	5	6	7	8	9	10	11	12	13	14	15	16	17	18	19	20	21
3/8	9/16	49	43	34	29	25	21	19	17											
1/2	1 1/16	31	27	22	18	16	14	12	11											
5/8	7/8	18	15	12	10	9	8	7	6	6	5	5								
3/4	1	13	11	9	8	7	6	5	5	4	4	4	3	3	3	3	3	2	2	2

 SET1.7KTA is not suitable for screen tube installations.

Estimating Guide for 22 oz. Cartridge and Plastic Screen Tubes – Installations per Cartridge

Rod Dia. (in.)	Drill Bit Dia. (in.)	THREADED ROD INSERTED IN SCREEN TUBE																		
		HOLE DEPTH (inches)																		
		3 1/2	4	5	6	7	8	9	10	11	12	13	14	15	16	17	18	19	20	21
3/8	9/16	57	50	40	34	29	25	22	20											
1/2	1 1/16	30	26	21	17	15	13	12	10											
5/8	7/8	20	18	14	12	10	9	8	7	6	6	5								
3/4	1	15	13	10	9	7	6	6	5	5	4	4	4	3	3	3	3	3	3	2

Tables are estimations. Actual usage may vary depending on waste.
Note: Online adhesive cartridge quantity estimating tools are available by visiting www.strongtie.com

Estimating Guides for SET-XP, SET, ET-HP and EDOT Adhesives

Epoxy Adhesives

Estimating Guide for 56 oz. Cartridge using Threaded Rod – Installations per Cartridge

Rod Dia. (in.)	Drill Bit Dia. (in.)	THREADED ROD IN SOLID BASE MATERIAL																		
		HOLE DEPTH (inches)																		
		2	3	4	5	6	7	8	9	10	11	12	13	14	15	16	17	18	19	20
3/8	7/16	443	295	221	177	148	127	111	98	89	81	74	68	63	59	55	52	49	47	44
3/8	1/2	279	186	140	112	93	80	70	62	56	51	47	43	40	37	35	33	31	29	28
1/2	9/16	322	215	161	129	107	92	80	72	64	59	54	50	46	43	40	38	36	34	32
1/2	5/8	203	135	101	81	68	58	51	45	41	37	34	31	29	27	25	24	23	21	20
5/8	3/4	159	106	79	64	53	45	40	35	32	29	26	24	23	21	20	19	18	17	16
5/8	7/8	91	60	45	36	30	26	23	20	18	16	15	14	13	12	11	11	10	10	9
3/4	7/8	127	85	64	51	42	36	32	28	25	23	21	20	18	17	16	15	14	13	13
3/4	1	76	51	38	31	25	22	19	17	15	14	13	12	11	10	10	9	8	8	8
7/8	1	107	72	54	43	36	31	27	24	21	20	18	17	15	14	13	13	12	11	11
7/8	1 1/8	64	43	32	26	21	18	16	14	13	12	11	10	9	9	8	8	7	7	6
1	1 1/8	88	59	44	35	29	25	22	20	18	16	15	14	13	12	11	10	10	9	9
1	1 1/4	56	37	28	22	19	16	14	12	11	10	9	9	8	7	7	7	6	6	6
1 1/8	1 1/4	76	51	38	30	25	22	19	17	15	14	13	12	11	10	10	9	8	8	8
1 1/8	1 3/8	49	33	24	20	16	14	12	11	10	9	8	8	7	7	6	6	5	5	5
1 1/4	1 3/8	69	46	34	27	23	20	17	15	14	12	11	11	10	9	9	8	8	7	7
1 1/4	1 1/2	44	30	22	18	15	13	11	10	9	8	7	7	6	6	6	5	5	5	4

Estimating Guide for 56 oz. Cartridge using Rebar – Installations per Cartridge

Rebar Size (no.)	Drill Bit Dia. (in.)	REBAR IN SOLID BASE MATERIAL																		
		HOLE DEPTH (inches)																		
		2	3	4	5	6	7	8	9	10	11	12	13	14	15	16	17	18	19	20
3	7/16	593	395	296	237	198	169	148	132	119	108	99	91	85	79	74	70	66	62	59
3	1/2	332	222	166	133	111	95	83	74	66	60	55	51	47	44	42	39	37	35	33
4	9/16	489	326	244	195	163	140	122	109	98	89	81	75	70	65	61	57	54	51	49
4	5/8	259	172	129	103	86	74	65	57	52	47	43	40	37	34	32	30	29	27	26
5	3/4	208	139	104	83	69	60	52	46	42	38	35	32	30	28	26	25	23	22	21
5	7/8	105	70	52	42	35	30	26	23	21	19	17	16	15	14	13	12	12	11	10
6	7/8	167	111	83	67	56	48	42	37	33	30	28	26	24	22	21	20	19	18	17
6	1	89	59	45	36	30	25	22	20	18	16	15	14	13	12	11	10	10	9	9
7	1	145	97	73	58	48	42	36	32	29	26	24	22	21	19	18	17	16	15	15
7	1 1/8	76	51	38	30	25	22	19	17	15	14	13	12	11	10	9	9	8	8	8
8	1 1/8	125	83	62	50	42	36	31	28	25	23	21	19	18	17	16	15	14	13	12
8	1 1/4	68	46	34	27	23	20	17	15	14	12	11	11	10	9	9	8	8	7	7
9	1 1/4	112	75	56	45	37	32	28	25	22	20	19	17	16	15	14	13	12	12	11
9	1 3/8	62	41	31	25	21	18	15	14	12	11	10	10	9	8	8	7	7	7	6
10	1 1/2	60	40	30	24	20	17	15	13	12	11	10	9	9	8	7	7	7	6	6
10	1 3/4	29	20	15	12	10	8	7	7	6	5	5	5	4	4	4	3	3	3	3
11	1 5/8	57	38	29	23	19	16	14	13	11	10	10	9	8	8	7	7	6	6	6
11	1 7/8	28	19	14	11	9	8	7	6	6	5	5	4	4	4	4	3	3	3	3

Estimating Guide for 56 oz. Cartridge and Steel Screen Tubes – Installations per Cartridge

Rod Dia. (in.)	Drill Bit Dia. (in.)	THREADED ROD INSERTED IN SCREEN TUBE																		
		HOLE DEPTH (inches)																		
		3 1/2	4	5	6	7	8	9	10	11	12	13	14	15	16	17	18	19	20	21
3/8	9/16	125	109	87	73	62	55	49	44											
1/2	1 1/16	79	69	55	46	39	35	31	28											
5/8	7/8	45	39	31	26	22	20	17	16	14	13	12								
3/4	1	33	29	23	19	17	15	13	12	11	10	9	8	8	7	7	6	6	6	6

Estimating Guide for 56 oz. Cartridge and Plastic Screen Tubes – Installations per Cartridge

 SET1.7KTA is not suitable for screen tube installations.

Rod Dia. (in.)	Drill Bit Dia. (in.)	THREADED ROD INSERTED IN SCREEN TUBE																		
		HOLE DEPTH (inches)																		
		3 1/2	4	5	6	7	8	9	10	11	12	13	14	15	16	17	18	19	20	21
3/8	9/16	146	128	102	85	73	64	57	51											
1/2	1 1/16	76	66	53	44	38	33	30	27											
5/8	7/8	52	45	36	30	26	23	20	18	17	15	14								
3/4	1	38	33	26	22	19	17	15	13	12	11	10	9	9	8	8	7	7	7	6

Estimating Guides for SET-XP, SET, ET-HP and EDOT Adhesives

Epoxy Adhesives

Estimating Guide for 1 Gallon (128 oz.) System using Threaded Rod – Installations per Gallon

Rod Dia. (in.)	Drill Bit Dia. (in.)	THREADED ROD IN SOLID BASE MATERIAL HOLE DEPTH (inches)																		
		2	3	4	5	6	7	8	9	10	11	12	13	14	15	16	17	18	19	20
3/8	7/16	1012	675	506	405	337	289	253	225	202	184	169	156	145	135	126	119	112	107	101
3/8	1/2	638	425	319	255	213	182	160	142	128	116	106	98	91	85	80	75	71	67	64
1/2	9/16	735	490	368	294	245	210	184	163	147	134	123	113	105	98	92	86	82	77	74
1/2	5/8	464	309	232	186	155	133	116	103	93	84	77	71	66	62	58	55	52	49	46
5/8	3/4	363	242	181	145	121	104	91	81	73	66	60	56	52	48	45	43	40	38	36
5/8	7/8	207	138	104	83	69	59	52	46	41	38	35	32	30	28	26	24	23	22	21
3/4	7/8	291	194	146	116	97	83	73	65	58	53	49	45	42	39	36	34	32	31	29
3/4	1	175	116	87	70	58	50	44	39	35	32	29	27	25	23	22	21	19	18	17
7/8	1	245	163	123	98	82	70	61	54	49	45	41	38	35	33	31	29	27	26	25
7/8	1 1/8	146	98	73	59	49	42	37	33	29	27	24	23	21	20	18	17	16	15	15
1	1 1/8	202	135	101	81	67	58	50	45	40	37	34	31	29	27	25	24	22	21	20
1	1 1/4	127	85	64	51	42	36	32	28	25	23	21	20	18	17	16	15	14	13	13
1 1/8	1 1/4	174	116	87	70	58	50	43	39	35	32	29	27	25	23	22	20	19	18	17
1 1/8	1 3/8	112	75	56	45	37	32	28	25	22	20	19	17	16	15	14	13	12	12	11
1 1/4	1 3/8	157	105	78	63	52	45	39	35	31	29	26	24	22	21	20	18	17	17	16
1 1/4	1 1/2	101	68	51	41	34	29	25	23	20	18	17	16	14	13	12	11	11	10	10

Estimating Guide for 1 Gallon (128 oz.) System using Rebar – Installations per Gallon

Rebar Size (no.)	Drill Bit Dia. (in.)	REBAR IN SOLID BASE MATERIAL HOLE DEPTH (inches)																		
		2	3	4	5	6	7	8	9	10	11	12	13	14	15	16	17	18	19	20
3	7/16	1354	903	677	542	451	387	339	301	271	246	226	208	193	181	169	159	150	143	135
3	1/2	759	506	380	304	253	217	190	169	152	138	127	117	108	101	95	89	84	80	76
4	9/16	1116	744	558	446	372	319	279	248	223	203	186	172	159	149	140	131	124	117	112
4	5/8	591	394	296	236	197	169	148	131	118	107	99	91	84	79	74	70	66	62	59
5	3/4	476	317	238	190	159	136	119	106	95	87	79	73	68	63	60	56	53	50	48
5	7/8	240	160	120	96	80	68	60	53	48	44	40	37	34	32	30	28	27	25	24
6	7/8	381	254	191	152	127	109	95	85	76	69	64	59	54	51	48	45	42	40	38
6	1	204	136	102	81	68	58	51	45	41	37	34	31	29	27	25	24	23	21	20
7	1	332	222	166	133	111	95	83	74	66	60	55	51	47	44	42	39	37	35	33
7	1 1/8	173	116	87	69	58	50	43	39	35	32	29	27	25	23	22	20	19	18	17
8	1 1/8	285	190	143	114	95	82	71	63	57	52	48	44	41	38	36	34	32	30	29
8	1 1/4	156	104	78	63	52	45	39	35	31	28	26	24	22	21	20	18	17	16	16
9	1 1/4	257	171	128	103	86	73	64	57	51	47	43	39	37	34	32	30	29	27	26
9	1 3/8	141	94	71	56	47	40	35	31	28	26	24	22	20	19	18	17	16	15	14
10	1 1/2	136	91	68	54	45	39	34	30	27	25	23	21	19	18	17	16	15	14	14
10	1 3/4	67	45	34	27	22	19	17	15	13	12	11	10	10	9	8	8	7	7	7
11	1 5/8	131	87	65	52	44	37	33	29	26	24	22	20	19	17	16	15	15	14	13
11	1 7/8	64	43	32	26	21	18	16	14	13	12	11	10	9	9	8	8	7	7	6

Estimating Guide for 1 Gallon (128 oz.) System using Steel Screen Tubes – Installations per Gallon

Rod Dia. (in.)	Drill Bit Dia. (in.)	THREADED ROD INSERTED IN SCREEN TUBE HOLE DEPTH (inches)																		
		3 1/2	4	5	6	7	8	9	10	11	12	13	14	15	16	17	18	19	20	21
3/8	9/16	285	250	200	167	143	125	111	100											
1/2	1 1/16	180	158	126	105	90	79	70	63											
5/8	7/8	102	89	71	60	51	45	40	36	32	30	27								
3/4	1	76	66	53	44	38	33	29	27	24	22	20	19	18	17	16	15	14	13	13

Estimating Guide for 1 Gallon (128 oz.) System using Plastic Screen Tubes – Installations per Gallon



SET1.7KTA is not suitable for screen tube installations.

Rod Dia. (in.)	Drill Bit Dia. (in.)	THREADED ROD INSERTED IN SCREEN TUBE HOLE DEPTH (inches)																		
		3 1/2	4	5	6	7	8	9	10	11	12	13	14	15	16	17	18	19	20	21
3/8	9/16	334	293	234	195	167	146	130	117											
1/2	1 1/16	173	152	121	101	87	76	67	61											
5/8	7/8	119	104	83	69	59	52	46	41	38	35	32								
3/4	1	86	76	60	50	43	38	34	30	27	25	23	22	20	19	18	17	16	15	14

Tables are estimations. Actual usage may vary depending on waste.

Note: Online adhesive cartridge quantity estimating tools are available by visiting www.strongtie.com

Acrylic Anchoring Adhesive



Simpson Strong-Tie[®] acrylic adhesive delivers consistent performance for high-strength anchor grouting in a wide range of weather conditions. Our acrylic formulations cure fast and are suitable for damp, wet or water-filled holes.

Simpson Strong-Tie also makes dispensing acrylic adhesives easier than ever by providing a variety of manual and pneumatic tools as well as accessories designed to make dispensing adhesive as efficient as possible.



AT High-Strength Anchoring Adhesive

AT is a two-component, high-solids, 10:1 ratio, acrylic-based adhesive for use as a high strength, anchor-grouting material. Formulated for use in all types of weather, AT is designed to dispense easily and cure at temperatures down to 0°F. Resin and initiator are dispensed and mixed simultaneously through the mixing nozzle. AT meets the physical requirements of ASTM C881, Type I & IV, Grade 3, Classes A, B & C, except AT is a non-epoxy product formulated for fast cure time.

- USES:**
- Threaded rod anchoring
 - Rebar doweling
 - Pick-proof sealant around doors, windows and fixtures

CODES: ICC-ES ER-5791* (CMU & URM); City of L.A. RR25459*; Florida FL 14832.1*; NSF/ANSI Standard 61 (11 in²/5000 gal); Multiple DOT listings. The load tables list values based upon results from the most recent testing and may not reflect those in current code reports. Where code jurisdictions apply, consult the current reports for applicable load values. *Applies to all AT products.

APPLICATION: Surfaces to receive adhesive must be clean and free of frost. The base material temperature must be 0°F or above at the time of installation. For information on installations below 0°F contact Simpson Strong-Tie. Mixed material in nozzle can harden in 5–7 minutes. For installations in or through standing water, see page 70 for details.

INSTALLATION: See pages 70–71.

SHELF LIFE: 12 months from date of manufacture in unopened cartridge.

STORAGE CONDITIONS: For best results store between 32°F – 80°F. Partially used cartridges can be stored for a limited time by leaving nozzle in place. To re-use, attach new nozzle.

COLOR: Resin — white, initiator — black
When properly mixed, adhesive will be a uniform gray color.

CLEAN UP: Uncured material — Wipe up with cotton cloths. If desired scrub area with abrasive, water-based cleaner and flush with water. If approved, solvents such as ketones (MEK, acetone, etc.), lacquer thinner, or adhesive remover can be used. **DO NOT USE SOLVENTS TO CLEAN ADHESIVE FROM SKIN.** Take appropriate precautions when handling flammable solvents. Solvents may damage surfaces to which they are applied. Cured material — Chip or grind off surface.

TEST CRITERIA: Anchors installed with AT adhesive have been tested in accordance with ICC-ES's *Acceptance Criteria for Adhesive Anchors (AC58)*.

In addition, anchors installed with AT adhesive have been tested in accordance with ICC-ES's *Acceptance Criteria for Unreinforced Masonry Anchors (AC60)* and *NSF/ANSI Standard 61, Drinking Water System Components - Health Effects*.

PROPERTY	TEST METHOD	RESULTS
Consistency (77°F)	ASTM C 881	Non-sag/thixotropic paste
Heat deflection	ASTM D 648	149°F (65°C)
Bond strength (moist cure)	ASTM C 882	2,900 psi (2 days) 2,970 psi (14 days)
Water absorption	ASTM D 570	0.23% (24 hours)
Compressive yield strength	ASTM D 695	10,210 psi (7 days)
Compressive modulus	ASTM D 695	571,000 psi (7 days)
Gel time (77°F)	ASTM C 881	9 min – Thin film

CHEMICAL RESISTANCE Very good to excellent against distilled water and inorganic acids. Fair to good against organic acids and alkalis, inorganic alkalis, and many organic solvents. Poor against ketones. For more detailed information, visit www.strongtie.com

The performance of this product results from its unique formulation which is proprietary to Simpson Strong-Tie. The product may also be protected by one or more of U.S. Pats. 5,643,994; 5,965,635; 6,228,207, licensed from ITW.



AT13

AT30



AMN19Q

ADT813S



When the concrete temperature is at or below freezing, ensure any holes drilled in advance are free of frost or ice.

SUGGESTED SPECIFICATIONS: Anchoring adhesive shall be a two-component acrylic based system supplied in manufacturer's standard side-by-side or coaxial cartridge and dispensed through a static-mixing nozzle supplied by the manufacturer. Adhesive shall meet the physical requirements of ASTM C-881 for Type I and IV, Grade 3, Class A, B and C and must develop a minimum 10,210 psi compressive yield strength after 7 day cure. Adhesive must have a heat deflection temperature of a minimum 149°F (65°C). Adhesive shall be AT adhesive from Simpson Strong-Tie, Pleasanton, CA. Anchors shall be installed per Simpson Strong-Tie instructions for AT adhesive.

ACCESSORIES: See pages 72–77 for information on dispensing tools, mixing nozzles and other accessories.

IMPORTANT – See Pages 70–71 for Installation Instructions

AT High-Strength Anchoring Adhesive

Acrylic Adhesive

AT Cartridge Systems

Model No.	Capacity ounces (cubic inches)	Cartridge Type	Carton Quantity	Dispensing Tool(s)	Mixing ³ Nozzle
AT13	12.5 (23.5)	side-by-side	10	ADT813S	AMN19Q
AT30	30 (54.2)	side-by-side	5	ADT30S, ADTA30P, or ADT30CKT	

1. Cartridge estimation guides are available on pages 67–69.
2. Detailed information on dispensing tools, mixing nozzles and other adhesive accessories is available on pages 72–77.
3. Use only appropriate Simpson Strong-Tie® mixing nozzle in accordance with Simpson Strong-Tie instructions. Modification or improper use of mixing nozzle may impair AT adhesive performance.

Cure Schedule

Base Material Temperature		Cure Time
°F	°C	
0	-18	24 hrs.
25	-4	8 hrs.
40	4	4 hrs.
60	16	1 hr.
70	21	30 min.
100	38	20 min.

In-Service Temperature Sensitivity

Base Material Temperature		Percent Allowable Load for T _{inst} = 0°F	Percent Allowable Load for T _{inst} ≥ 70°F
°F	°C		
0	-18	100%	100%
32	0	100%	100%
70	21	100%	100%
110	43	82%	82%
135	57	74%	82%
150	66	38%	65%
180	82	22%	28%

1. Refer to in-service temperature sensitivity chart for allowable bond strength reduction for in-service temperature. See page 225 for more information.
2. T_{inst} is the base material temperature during installation and curing of the adhesive.
3. Percent allowable load for T_{inst} = 0°F (-18°C) is to be used for T_{inst} between 0°F (-18°C) and 70°F (21°C).
4. Percent allowable load may be linearly interpolated for intermediate base material in-service temperatures.
5. °C = (°F-32) / 1.8

Tension Loads for Threaded Rod Anchors in Normal-Weight Concrete (continued on next page)

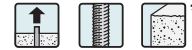

Rod Dia. in. (mm)	Drill Bit Dia. in.	Embed. Depth in. (mm)	Critical Edge Dist. in. (mm)	Critical Spacing Dist. in. (mm)	Tension Load Based on Bond Strength			Tension Load Based on Steel Strength		
					f' _c ≥ 2000 psi (13.8 MPa) Concrete			F1554 Grade 36	A193 GR B7	F593 304SS
					Ultimate lbs. (kN)	Std. Dev. lbs. (kN)	Allowable lbs. (kN)	Allowable lbs. (kN)	Allowable lbs. (kN)	Allowable lbs. (kN)
3/8 (9.5)	7/16	1 1/4 (44)	2 5/8 (67)	7 (178)	3,362 (15.0)	99 (0.4)	840 (3.7)	2,105 (9.4)	4,535 (20.2)	3,630 (16.1)
		3 1/2 (89)	5 1/4 (133)	6 1/8 (156)	8,937 (39.8)	314 (1.4)	2,235 (9.9)			
		4 1/2 (114)	6 3/4 (171)	18 (457)	10,411 (46.3)	525 (2.3)	2,605 (11.6)			
1/2 (12.7)	9/16	2 1/8 (54)	3 3/8 (81)	8 1/2 (216)	5,252 (23.4)	501 (2.2)	1,315 (5.8)	3,750 (16.7)	8,080 (35.9)	6,470 (28.8)
		4 1/4 (108)	6 3/8 (162)	7 1/2 (191)	16,668 (74.1)	822 (3.7)	4,165 (18.5)			
		6 (152)	9 (229)	24 (610)	19,182 (85.3)	331 (1.5)	4,795 (21.3)			
5/8 (15.9)	1 1/16	2 1/2 (64)	3 3/4 (95)	10 (254)	8,495 (37.8)	561 (2.5)	2,125 (9.5)	5,875 (26.1)	12,660 (56.3)	10,120 (45.0)
		4 (102)	5 5/8 (143)	16 (406)	•	•	4,315 (19.2)			
		5 1/2 (140)	7 1/2 (191)	9 5/8 (244)	26,025 (115.8)	1,866 (8.3)	6,505 (28.9)			
		7 7/8 (189)	10 3/8 (276)	29 1/4 (756)	•	•	7,215 (32.1)			
		9 3/8 (238)	14 1/4 (359)	37 1/2 (953)	31,683 (140.9)	1,571 (7.0)	7,920 (35.2)			

*See page 13 for an explanation of the load table icons

See Notes on Next Page

3/4" – 1 1/4" Diameters on next page



AT High-Strength Anchoring Adhesive

Tension Loads for Threaded Rod Anchors in Normal-Weight Concrete (continued from previous page)



Rod Dia. in. (mm)	Drill Bit Dia. in.	Embed. Depth in. (mm)	Critical Edge Dist. in. (mm)	Critical Spacing Dist. in. (mm)	Tension Load Based on Bond Strength			Tension Load Based on Steel Strength		
					f' _c ≥ 2000 psi (13.8 MPa) Concrete			F1554 Grade 36	A193 GR B7	F593 304SS
					Ultimate lbs. (kN)	Std. Dev. lbs. (kN)	Allowable lbs. (kN)	Allowable lbs. (kN)	Allowable lbs. (kN)	Allowable lbs. (kN)
3/4 (19.1)	1 3/16	3 3/8 (86)	5 1/16 (129)	13 1/2 (343)	12,991 (57.8)	725 (3.2)	3,250 (14.5)	8,460 (37.6)	18,230 (81.1)	12,400 (55.2)
		5 1/16 (129)	7 5/8 (194)	20 1/4 (514)	•	•	6,330 (28.2)			
		6 3/4 (171)	10 3/8 (257)	11 7/8 (302)	37,616 (167.3)	1,817 (8.1)	9,405 (41.8)			
		9 (229)	13 1/2 (343)	36 (914)	•	•	10,000 (44.5)			
		11 1/4 (286)	16 7/8 (429)	45 (1143)	42,381 (188.5)	683 (3.0)	10,595 (47.1)			
7/8 (22.2)	1	3 3/8 (98)	5 13/16 (148)	15 1/2 (394)	14,206 (63.2)	457 (2.0)	3,550 (15.8)	11,500 (51.2)	24,785 (110.2)	16,860 (75.0)
		5 13/16 (148)	8 3/4 (222)	23 1/4 (591)	•	•	7,130 (31.7)			
		7 3/4 (197)	11 5/8 (295)	13 5/8 (346)	42,848 (190.6)	3,155 (14.0)	10,710 (47.6)			
		10 7/16 (265)	15 5/8 (397)	41 1/4 (1060)	•	•	12,250 (54.5)			
		13 1/8 (333)	19 5/8 (498)	52 1/2 (1334)	55,148 (245.3)	5,673 (25.2)	13,785 (61.3)			
1 (25.4)	1 1/16	4 1/2 (114)	6 3/4 (171)	18 (457)	20,797 (92.5)	1,763 (7.8)	5,200 (23.1)	15,025 (66.8)	32,380 (144.0)	22,020 (97.9)
		6 3/4 (171)	10 1/8 (257)	27 (686)	•	•	10,165 (45.2)			
		9 (229)	13 1/2 (343)	15 3/4 (400)	60,504 (269.1)	2,065 (9.2)	15,125 (67.3)			
		12 (305)	18 (457)	48 (1219)	•	•	17,880 (79.5)			
		15 (381)	22 1/2 (572)	60 (1524)	82,529 (367.1)	5,146 (22.9)	20,630 (91.8)			
1 1/8 (28.6)	1 3/16	5 1/8 (130)	7 3/4 (197)	20 1/2 (521)	26,600 (118.3)	•	6,650 (29.6)	19,025 (84.6)	41,000 (182.4)	27,880 (124.0)
		7 7/8 (194)	11 1/2 (292)	30 1/2 (775)	•	•	11,780 (52.4)			
		10 1/8 (257)	15 1/4 (387)	17 3/4 (451)	67,600 (300.7)	•	16,900 (75.2)			
		13 1/2 (343)	20 1/4 (514)	54 (1372)	•	•	21,385 (95.1)			
		16 7/8 (429)	25 5/8 (645)	67 1/2 (1715)	103,460 (460.2)	•	25,865 (115.1)			
1 1/4 (31.8)	1 5/16	5 5/8 (143)	8 7/16 (214)	22 1/2 (572)	32,368 (144.0)	2,054 (9.1)	8,090 (36.0)	23,490 (104.5)	50,620 (225.2)	34,420 (153.1)
		8 7/16 (214)	12 3/4 (324)	33 3/4 (857)	•	•	13,090 (58.2)			
		11 1/4 (286)	16 7/8 (429)	19 3/4 (502)	72,363 (321.9)	7,457 (33.2)	18,090 (80.5)			
		15 (381)	22 1/2 (572)	60 (1524)	•	•	24,860 (110.6)			
		18 3/4 (476)	28 1/8 (714)	75 (1905)	126,500 (562.7)	15,813 (70.3)	31,625 (140.7)			

*See page 13 for an explanation of the load table icons

- Reference page 225 for oversize holes.
- Allowable load must be the lesser of the bond or steel strength.
- The allowable loads listed under allowable bond are based on a safety factor of 4.0.
- Refer to allowable load-adjustment factors for spacing and edge distance on pages 62, 64 and 65.
- Refer to in-service temperature sensitivity chart for allowable load adjustment for temperature.
- Anchors are permitted to be used within fire-resistive construction, provided the anchors resist wind or seismic loads only. For use in fire-resistive construction, the anchors can also be permitted to be used to resist gravity loads, provided special consideration has been given to fire-exposure conditions.
- Anchors are not permitted to resist tension forces in overhead or wall installations unless proper consideration is given to fire-exposure and elevated-temperature conditions.

AT High-Strength Anchoring Adhesive

Acrylic Adhesive

Shear Loads for Threaded Rod Anchors in Normal-Weight Concrete

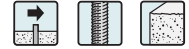

*See page 13 for an explanation of the load table icons

Rod Dia. in. (mm)	Drill Bit Dia. in.	Embed. Depth in. (mm)	Critical Edge Dist. in. (mm)	Critical Spacing Dist. in. (mm)	Shear Load Based on Concrete Edge Distance			Shear Load Based on Steel Strength		
					f' _c ≥ 2000 psi (13.8 MPa) Concrete			F1554 Grade 36	A193 GR B7	F593 304SS
					Ultimate lbs. (kN)	Std. Dev. lbs. (kN)	Allowable lbs. (kN)	Allowable lbs. (kN)	Allowable lbs. (kN)	Allowable lbs. (kN)
3/8 (9.5)	7/16	1 3/4 (44)	5 1/4 (133)	2 5/8 (67)	4,869 (21.7)	369 (1.6)	1,215 (5.4)	1,085 (4.8)	2,340 (10.4)	1,870 (8.3)
		3 1/2 (89)		5 1/4 (133)	5,540 (24.6)	620 (2.8)	1,385 (6.2)			
		4 1/2 (114)		5 1/4 (133)	•	•	1,385 (6.2)			
1/2 (12.7)	9/16	2 1/8 (54)	6 5/8 (162)	3 3/4 (83)	8,318 (37.0)	643 (2.9)	2,080 (9.3)	1,930 (8.6)	4,160 (18.5)	3,330 (14.8)
		4 1/4 (108)		6 5/8 (162)	9,998 (44.5)	522 (2.3)	2,500 (11.1)			
		6 (152)		6 5/8 (162)	•	•	2,500 (11.1)			
5/8 (15.9)	1 1/16	2 1/2 (64)	7 1/2 (191)	3 3/4 (95)	14,806 (65.9)	728 (3.2)	3,700 (16.5)	3,025 (13.5)	6,520 (29.0)	5,220 (23.2)
		5 1/2 (140)		8 3/4 (210)	15,692 (69.8)	305 (1.4)	3,925 (17.5)			
		9 5/8 (238)		8 3/4 (210)	•	•	3,925 (17.5)			
3/4 (19.1)	1 3/16	3 3/8 (86)	10 1/8 (257)	5 1/4 (130)	20,350 (90.5)	•	5,090 (22.6)	4,360 (19.4)	9,390 (41.8)	6,385 (28.4)
		6 3/4 (171)		10 1/8 (257)	20,350 (90.5)	1,521 (6.8)	5,090 (22.6)			
		11 1/4 (286)		10 1/8 (257)	•	•	5,090 (22.6)			
7/8 (22.2)	1	3 3/8 (98)	11 5/8 (295)	5 7/8 (149)	27,475 (122.2)	1,655 (7.4)	6,870 (30.6)	5,925 (26.4)	12,770 (56.8)	8,685 (38.6)
		7 3/4 (197)		11 5/8 (295)	30,876 (137.3)	1,714 (7.6)	7,720 (34.3)			
		13 1/8 (333)		11 5/8 (295)	•	•	7,720 (34.3)			
1 (25.4)	1 1/8	4 1/2 (114)	13 1/2 (343)	6 3/4 (171)	32,687 (145.4)	2,287 (10.2)	8,170 (36.3)	7,740 (34.4)	16,680 (74.2)	11,345 (50.5)
		9 (229)		13 1/2 (343)	33,858 (150.6)	2,035 (9.1)	8,465 (37.7)			
		15 (381)		13 1/2 (343)	•	•	8,465 (37.7)			
1 1/8 (28.6)	1 3/8	5 1/8 (130)	15 1/4 (387)	7 3/4 (197)	41,536 (184.8)	•	10,385 (46.2)	9,800 (43.6)	21,125 (94.0)	14,365 (63.9)
		10 1/8 (257)		15 1/4 (387)	49,812 (221.6)	•	12,455 (55.4)			
		16 7/8 (429)		15 1/4 (387)	•	•	12,455 (55.4)			
1 1/4 (31.8)	1 5/8	5 5/8 (143)	16 3/8 (429)	8 1/2 (216)	50,385 (224.1)	1,090 (4.8)	12,595 (56.0)	12,100 (53.8)	26,075 (116.0)	17,730 (78.9)
		11 1/4 (286)		16 3/8 (429)	65,765 (292.5)	4,636 (20.6)	16,440 (73.1)			
		18 3/4 (476)		16 3/8 (429)	•	•	16,440 (73.1)			

1. Allowable load must be the lesser of the load based on concrete edge distance or steel strength.
2. The allowable loads based on concrete edge distance are based on a safety factor of 4.0.
3. Refer to allowable load-adjustment factors for spacing and edge distance on pages 63 and 65.
4. Refer to in-service temperature sensitivity chart for allowable load adjustment for temperature.
5. Anchors are permitted to be used within fire-resistive construction, provided the anchors resist wind or seismic loads only. For use in fire-resistive construction, the anchors can also be permitted to be used to resist gravity loads, provided special consideration has been given to fire-exposure conditions.

Tension Loads for Rebar Dowels
in Normal-Weight Concrete

Rebar Size No. (mm)	Drill Bit Dia. in.	Embed Depth in. (mm)	Critical Edge Dist. in. (mm)	Critical Spacing Dist. in. (mm)	Tension Load Based on Bond Strength						Tension Load Based on Steel Strength
					$f'_c \geq 2000$ psi (13.8 MPa) Concrete			$f'_c \geq 4000$ psi (27.6 MPa) Concrete			ASTM A615 Grade 60 Rebar
					Ultimate lbs. (kN)	Std. Dev. lbs. (kN)	Allowable lbs. (kN)	Ultimate lbs. (kN)	Std. Dev. lbs. (kN)	Allowable lbs. (kN)	Allowable lbs. (kN)
#3 (9.5)	1/2	3 1/2 (89)	5 1/4 (133)	6 1/8 (156)	8,245 (36.7)	849 (3.8)	2,060 (9.2)	•	•	2,060 (9.2)	2,640 (11.7)
		4 1/2 (114)	5 1/4 (133)	6 1/8 (156)	•	•	2,060 (9.2)	•	•	2,060 (9.2)	
#4 (12.7)	9/16	4 1/4 (108)	6 1/8 (162)	7 1/2 (191)	12,743 (56.7)	1,760 (7.8)	3,185 (14.2)	•	•	3,185 (14.2)	4,800 (21.4)
		5 7/8 (149)	8 7/8 (225)	23 1/2 (597)	•	•	3,185 (14.2)	•	•	3,985 (17.7)	
		7 1/2 (191)	11 1/4 (286)	30 (762)	•	•	3,185 (14.2)	19,124 (85.1)	854 (3.8)	4,780 (21.3)	
#5 (15.9)	3/4	5 1/2 (140)	7 1/2 (191)	9 5/8 (244)	20,396 (90.7)	1,412 (6.3)	5,100 (22.7)	•	•	5,100 (22.7)	7,440 (33.1)
		7 1/4 (184)	10 7/8 (276)	29 (737)	•	•	5,100 (22.7)	•	•	6,095 (27.1)	
		9 3/8 (191)	14 1/8 (359)	37 1/2 (953)	•	•	5,100 (22.7)	28,115 (125.1)	1,496 (6.7)	7,030 (31.3)	
#6 (19.1)	7/8	6 3/4 (171)	10 1/8 (257)	11 7/8 (302)	31,839 (141.6)	1,454 (6.5)	7,960 (35.4)	•	•	7,960 (35.4)	10,560 (47.0)
		9 (229)	13 1/2 (343)	36 (914)	•	•	7,960 (35.4)	•	•	8,730 (38.8)	
		11 1/4 (286)	16 7/8 (429)	45 (1143)	•	•	7,960 (35.4)	37,992 (169.0)	1,999 (8.9)	9,500 (42.3)	
#7 (22.2)	1	7 3/4 (197)	11 5/8 (295)	13 3/8 (346)	35,250 (156.8)	2,693 (12.0)	8,815 (39.2)	•	•	8,815 (39.2)	14,400 (64.1)
		10 1/2 (267)	15 3/4 (400)	42 (1067)	•	•	8,815 (39.2)	•	•	10,815 (48.1)	
		13 1/8 (333)	19 5/8 (498)	52 1/2 (1334)	•	•	8,815 (39.2)	50,889 (226.4)	3,717 (16.5)	12,720 (56.6)	
#8 (25.4)	1 1/8	9 (229)	13 1/2 (343)	15 3/4 (400)	49,973 (222.3)	5,023 (22.3)	12,495 (55.6)	•	•	12,495 (55.6)	18,960 (84.3)
		12 (305)	18 (457)	48 (1219)	•	•	12,495 (55.6)	•	•	16,325 (72.6)	
		15 (381)	22 1/2 (572)	60 (1524)	•	•	12,495 (55.6)	80,598 (358.5)	2,195 (9.8)	20,150 (89.6)	
#9 (28.6)	1 1/4	16 7/8 (429)	25 3/8 (645)	67 1/2 (1715)	•	•	•	96,096 (427.5)	489 (2.2)	24,025 (106.9)	24,000 (106.8)
#10 (31.8)	1 3/8	18 3/4 (476)	28 1/8 (714)	75 (1905)	•	•	•	124,031 (551.7)	2,447 (10.9)	31,010 (137.9)	30,480 (135.6)
#11 (34.9)	1 5/8	20 5/8 (524)	31 (787)	82 1/2 (2096)	•	•	•	166,059 (738.7)	4,222 (18.8)	41,515 (184.7)	37,440 (166.5)

- Oversize holes may reduce load capacity.
- Allowable load must be the lesser of the bond or steel strength.
- The allowable loads listed under allowable bond are based on a safety factor of 4.0.
- Refer to allowable load-adjustment factors for spacing and edge distance on pages 62, 64 and 65.
- Refer to in-service temperature sensitivity chart for allowable load adjustment for temperature.
- Anchors are permitted to be used within fire-resistive construction, provided the anchors resist wind or seismic loads only. For use in fire-resistive construction, the anchors can also be permitted to be used to resist gravity loads, provided special consideration has been given to fire-exposure conditions.
- Anchors are not permitted to resist tension forces in overhead or wall installations unless proper consideration is given to fire-exposure and elevated-temperature conditions.

*See page 13 for an explanation of the load table icons

AT High-Strength Anchoring Adhesive

Acrylic Adhesive

Shear Loads for Rebar Dowels in Normal-Weight Concrete



*See page 13 for an explanation of the load table icons

Rebar Size No. (mm)	Drill Bit Dia. in.	Embed. Depth in. (mm)	Critical Edge Dist. in. (mm)	Critical Spacing Dist. in. (mm)	Shear Load Based on Concrete Edge Distance			Shear Load Based on Steel Strength
					f'c ≥ 2000 psi (13.8 MPa) Concrete			ASTM A615 Grade 60 Rebar
					Ultimate lbs. (kN)	Std. Dev. lbs. (kN)	Allowable lbs. (kN)	Allowable lbs. (kN)
#3 (9.5)	1/2	3 1/2 (89)	6 (152)	5 1/4 (133)	8,294 (36.9)	515 (2.3)	2,075 (9.2)	1,680 (7.5)
		4 1/2 (114)			•	•	2,075 (9.2)	
#4 (12.7)	9/16	4 1/4 (108)	8 (203)	6 3/8 (162)	11,012 (49.0)	383 (1.7)	2,755 (12.3)	3,060 (13.6)
		7 1/2 (191)			•	•	2,755 (12.3)	
#5 (15.9)	3/4	5 1/2 (140)	10 (254)	8 1/4 (210)	15,758 (70.1)	1,154 (5.1)	3,940 (17.5)	4,740 (21.1)
		9 3/8 (238)			•	•	3,940 (17.5)	
#6 (19.1)	7/8	6 3/4 (171)	12 (305)	10 1/8 (257)	23,314 (103.7)	1,494 (6.6)	5,830 (25.9)	6,730 (29.9)
		11 1/4 (286)			•	•	5,830 (25.9)	
#7 (22.2)	1	7 3/4 (197)	14 (356)	11 3/8 (295)	32,662 (145.3)	5,588 (24.9)	8,165 (36.3)	9,180 (40.8)
		13 3/8 (333)			•	•	8,165 (36.3)	
#8 (25.4)	1 1/8	9 (229)	16 (406)	13 1/2 (343)	33,428 (148.7)	2,319 (10.3)	8,360 (37.2)	12,085 (53.8)
		15 (381)			•	•	8,360 (37.2)	

1. Allowable load must be the lesser of the load based on concrete edge distance or steel strength.
2. The allowable loads based on concrete edge distance are based on a safety factor of 4.0.
3. Refer to allowable load-adjustment factors for spacing and edge distance on pages 63 and 65.
4. Refer to in-service temperature sensitivity chart for allowable load adjustment for temperature.
5. Anchors are permitted to be used within fire-resistive construction, provided the anchors resist wind or seismic loads only. For use in fire-resistive construction, the anchors can also be permitted to be used to resist gravity loads, provided special consideration has been given to fire-exposure conditions.

Tension Loads for Threaded Rod Anchors in Normal-Weight Concrete Stemwall



Rod Dia. in. (mm)	Drill Bit Dia. in.	Embed. Depth in. (mm)	Stemwall Width in. (mm)	Min. Edge Dist. in. (mm)	Min. End Dist. in. (mm)	Tension Load Based on Bond Strength		Tension Load Based on Steel Strength
						f'c ≥ 2500 psi (17.2 MPa) Concrete		F1554 Grade 36
						Ultimate lbs. (kN)	Allowable lbs. (kN)	Allowable lbs. (kN)
5/8 (15.9)	1 1/16	10 (254.0)	6 (152.4)	1 3/4 (44.5)	5 (127.0)	12,913 (57.4)	3,230 (14.4)	5,875 (26.1)
7/8 (22.2)	1	15 (381.0)	8 (203.2)	1 3/4 (44.5)	5 (127.0)	21,838 (97.1)	5,460 (24.3)	11,500 (51.2)

1. Allowable load must be the lesser of the bond or steel strength.
2. The allowable loads listed under allowable bond are based on a safety factor of 4.0.
3. Refer to in-service temperature sensitivity chart for allowable load adjustment for temperature.
4. Anchors are permitted to be used within fire-resistive construction, provided the anchors resist wind or seismic loads only. For use in fire-resistive construction, the anchors can also be permitted to be used to resist gravity loads, provided special consideration has been given to fire-exposure conditions.

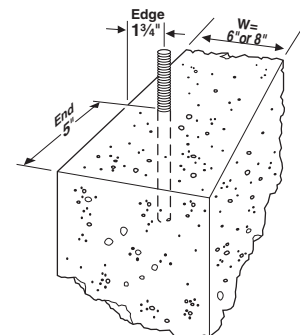

Edge and end distances for threaded rod in concrete foundation stemwall corner installation

AT High-Strength Anchoring Adhesive

Tension Loads for Threaded Rod Anchors in Sand-Lightweight Concrete



Rod Dia. in. (mm)	Drill Bit Dia. in.	Embed. Depth in. (mm)	Critical Edge Dist. in. (mm)	Critical Spacing Dist. in. (mm)	Tension Load Based on Bond Strength			Tension Load Based on Steel Strength		
					f'c ≥ 3000 psi (20.7 MPa) Lightweight Concrete			F1554 Grade 36	A193 GR B7	F593 304SS
					Ultimate lbs. (kN)	Std. Dev. lbs. (kN)	Allowable lbs. (kN)	Allowable lbs. (kN)	Allowable lbs. (kN)	Allowable lbs. (kN)
3/8 (9.5)	7/16	1 3/4 (44)	2 5/8 (67)	3 1/2 (89)	2,842 (12.6)	226 (1.0)	710 (3.2)	2,105 (9.4)	4,535 (20.2)	3,630 (16.1)
		3 1/2 (89)	5 1/4 (133)	7 (178)	5,132 (22.8)	762 (3.4)	1,280 (5.7)			
1/2 (12.7)	9/16	2 1/8 (54)	3 1/8 (79)	4 1/4 (108)	4,415 (19.6)	454 (2.0)	1,100 (4.9)	3,750 (16.7)	8,080 (35.9)	6,470 (28.8)
		4 1/4 (108)	6 3/8 (162)	8 1/2 (216)	6,709 (29.8)	1,002 (4.5)	1,675 (7.5)			
5/8 (15.9)	1 1/16	2 1/2 (64)	3 3/4 (95)	5 (127)	5,568 (24.8)	498 (2.2)	1,390 (6.2)	5,875 (26.1)	12,660 (56.3)	10,120 (45.0)
		5 (127)	7 1/2 (191)	10 (254)	6,298 (28.0)	1,155 (5.1)	1,575 (7.0)			

*See page 13 for an explanation of the load table icons

1. Oversize holes may reduce load capacity.
2. Allowable load must be the lesser of the bond or steel strength.
3. 100% of the allowable load is permitted at critical spacing. No reduction in spacing is allowed.
4. Refer to allowable load-adjustment factors for edge distance on page 66.
5. Refer to in-service temperature sensitivity chart for allowable load adjustment for temperature.
6. Anchors are permitted to be used within fire-resistive construction, provided the anchors resist wind or seismic loads only. For use in fire-resistive construction, the anchors can also be permitted to be used to resist gravity loads, provided special consideration has been given to fire-exposure conditions.
7. Anchors are not permitted to resist tension forces in overhead or wall installations unless proper consideration is given to fire-exposure and elevated-temperature conditions.
8. The allowable loads listed under allowable bond are based on a safety factor of 4.0.

Shear Loads for Threaded Rod Anchors in Sand-Lightweight Concrete



Rod Dia. in. (mm)	Drill Bit Dia. in.	Embed. Depth in. (mm)	Critical Edge Dist. in. (mm)	Critical Spacing Dist. in. (mm)	Shear Load Based on Concrete Edge Distance			Shear Load Based on Steel Strength		
					f'c ≥ 3000 psi (20.7 MPa) Lightweight Concrete			F1554 Grade 36	A193 GR B7	F593 304SS
					Ultimate lbs. (kN)	Std. Dev. lbs. (kN)	Allowable lbs. (kN)	Allowable lbs. (kN)	Allowable lbs. (kN)	Allowable lbs. (kN)
3/8 (9.5)	7/16	1 3/4 (44)	2 5/8 (67)	3 1/2 (89)	3,042 (13.5)	249 (1.1)	760 (3.4)	1,085 (4.8)	2,340 (10.4)	1,870 (8.3)
		3 1/2 (89)	5 1/4 (133)	7 (178)	5,320 (23.7)	187 (0.8)	1,330 (5.9)			
1/2 (12.7)	9/16	2 1/8 (54)	3 1/8 (79)	4 1/4 (108)	4,076 (18.1)	458 (2.0)	1,020 (4.5)	1,930 (8.6)	4,160 (18.5)	3,330 (14.8)
		4 1/4 (108)	6 3/8 (162)	8 1/2 (216)	9,838 (43.8)	625 (2.8)	2,460 (10.9)			
5/8 (15.9)	1 1/16	2 1/2 (64)	3 3/4 (95)	5 (127)	5,360 (23.8)	351 (1.6)	1,340 (6.0)	3,025 (13.5)	6,520 (29.0)	5,220 (23.2)
		5 (127)	7 1/2 (191)	10 (254)	12,430 (55.3)	518 (2.3)	3,105 (13.8)			

*See page 13 for an explanation of the load table icons

1. Allowable load must be the lesser of the load based on concrete edge distance or steel strength.
2. The allowable loads based on concrete edge distance are based on a safety factor of 4.0.
3. Refer to allowable load-adjustment factors for edge distance on page 66.
4. Refer to in-service temperature sensitivity chart for allowable load adjustment for temperature.
5. Anchors are permitted to be used within fire-resistive construction, provided the anchors resist wind or seismic loads only. For use in fire-resistive construction, the anchors can also be permitted to be used to resist gravity loads, provided special consideration has been given to fire-exposure conditions.
6. 100% of the allowable load is permitted at critical spacing. No reduction in spacing is allowed.

AT High-Strength Anchoring Adhesive

Acrylic Adhesive

Tension and Shear Loads for Threaded Rod Anchors in 6 and 8-Inch Normal-Weight Grout-Filled CMU

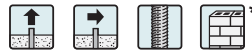

Rod Dia. in. (mm)	Drill Bit Dia. in.	Embed. Depth in. (mm)	Min. Edge Dist. in. (mm)	Min. End Dist. in. (mm)	Min. Spacing Dist. in. (mm)	6-Inch Grout-Filled CMU Allowable Loads Based on CMU Strength		8-Inch Grout-Filled CMU Allowable Loads Based on CMU Strength	
						Tension	Shear	Tension	Shear
						Allowable lbs. (kN)	Allowable lbs. (kN)	Allowable lbs. (kN)	Allowable lbs. (kN)
Anchor Installed in Face Shell (See Figure 1)									
1/2 (12.7)	9/16	4 1/4 (108)	12 (305)	12 (305)	17 (432)	770 (3.4)	1,325 (5.9)	770 (3.4)	1,325 (5.9)
3/4 (19.1)	13/16	6 3/4 (171)	12 (305)	4 (102)	27 (686)	•	•	1,375 (6.1)	•
				12 (305)	27 (686)	•	•	•	2,670 (11.9)
Anchor Installed in Mortar "T" Joint (See Figure 2)									
3/4 (19.1)	13/16	6 3/4 (171)	16 (406)	8 (203)	27 (686)	•	•	•	1,030 (4.6)

See Notes 1-7 Below

*See page 13 for an explanation of the load table icons

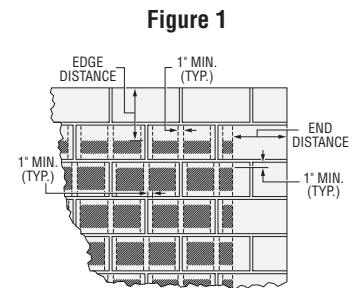
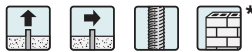

Figure 1
Allowable anchor placement in grouted CMU face shell

Tension and Shear Loads for Threaded Rod Anchors in 6 and 8-Inch Normal-Weight Grout-Filled CMU



Rod Dia. in. (mm)	Drill Bit Dia. in.	Embed. Depth in. (mm)	Min. Edge Dist. in. (mm)	Min. End Dist. in. (mm)	Min. Spacing Dist. in. (mm)	6 and 8-Inch Grout-Filled CMU Allowable Loads Based on CMU Strength		
						Tension	Shear Perpendicular ⁸	Shear Parallel ⁹
						Allowable lbs. (kN)	Allowable lbs. (kN)	Allowable lbs. (kN)
Anchor Installed in Cell Opening (Top-of-Wall) (See Figure 3)								
1/2 (12.7)	9/16	4 1/4 (108)	1 3/4 (44)	11 (279)	17 (432)	650 (2.9)	285 (1.3)	705 (3.1)
5/8 (15.9)	1 1/16	5 (127)	1 3/4 (44)	11 (279)	20 (508)	815 (3.6)	330 (1.5)	755 (3.4)
						12 (305)	11 (279)	48 (1219)
7/8 (22.2)	1	12 (305)	1 3/4 (44)	11 (279)	48 (1219)	1,385 (6.2)	290 (1.3)	1,030 (4.6)

1. Threaded rods must comply with ASTM F1554 Grade 36 minimum.
2. Values for 6- and 8-inch wide concrete masonry units (CMU) with a minimum specified compressive strength of masonry, f'_m , at 28 days is 1500 psi.
3. Embedment depth is measured from the outside face of the concrete masonry unit for installations through a face shell.
4. Allowable loads may be increased 33 1/3% for short-term loading due to wind or seismic forces where permitted by code.
5. Refer to in-service temperature sensitivity chart for allowable load adjustment for temperature.
6. The tabulated allowable loads are based on a safety factor of 5.0 for installations under the IBC and IRC.
7. Anchors must be spaced a minimum distance of four times the anchor embedment.
8. Shear load applied perpendicular to edge of CMU wall.
9. Shear load applied parallel to edge of CMU wall.

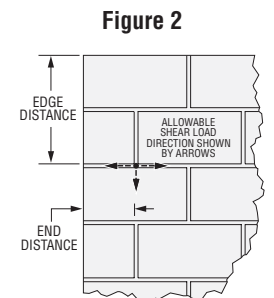
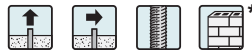

Figure 2
Anchor placement in grouted CMU mortar "T" joint

Tension and Shear Loads for Threaded Rod Anchors in Lightweight, Medium-Weight and Normal-Weight Hollow CMU



Rod Dia. in. (mm)	Drill Bit Dia. in.	Embed. Depth in. (mm)	Min. Edge Dist. in. (mm)	Min. End Dist. in. (mm)	6 and 8-Inch Hollow CMU Allowable Loads Based on CMU Strength			
					Tension		Shear	
					Ultimate lbs. (kN)	Allowable lbs. (kN)	Ultimate lbs. (kN)	Allowable lbs. (kN)
Anchor Installed in Face Shell with Simpson Strong-Tie® Stainless-Steel Screen Tube (See Figure 4)								
3/8 (9.5)	9/16	3 (76.2)	4 (101.6)	4 5/8 (117.5)	1,400 (6.2)	280 (1.2)	1,326 (5.9)	265 (1.2)
1/2 (12.7)	1 1/16	3 (76.2)	4 (101.6)	4 5/8 (117.5)	•	280 (1.2)	•	265 (1.2)
5/8 (15.9)	7/8	3 (76.2)	4 (101.6)	4 5/8 (117.5)	•	280 (1.2)	•	265 (1.2)

See Notes 1, 2, 3, 5, 6, 7 Above

1. Set drill to rotation only mode when drilling into hollow CMU.
2. Allowable loads may not be increased for short-term loading due to wind or seismic forces.

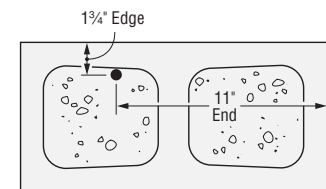

Figure 3
Anchor installed in cell opening (top of wall)

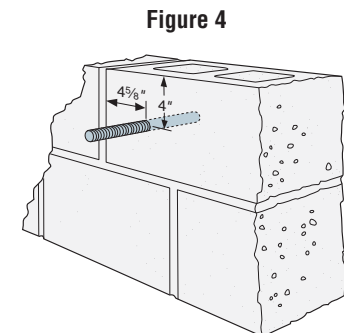
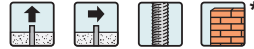

Figure 4
Anchor installed in face shell w/ screen tube in hollow cell

AT High-Strength Anchoring Adhesive

Tension and Shear Loads for Installations in Unreinforced Brick Masonry Walls Minimum URM Wall Thickness is 13" (3 wythes thick)



Rod/Rebar Dia./Size in. (mm)	Drill Bit Dia. in.	Embed. Depth in. (mm)	Min. Edge/End Dist. in. (mm)	Min. Vertical Spacing Dist. in. (mm)	Min. Horiz. Spacing Dist. in. (mm)	Tension Load Based on URM Strength		Shear Load Based on URM Strength	
						Minimum Net Mortar Strength = 50 psi		Minimum Net Mortar Strength = 50 psi	
						Allowable lbs. (kN)	Allowable lbs. (kN)	Allowable lbs. (kN)	Allowable lbs. (kN)
Configuration A (Simpson Strong-Tie® ATS or ATSP Screen Tube Required)									
3/4 (19.1)	1	8 (203)	24 (610)	18 (457)	18 (457)	•	•	1,000 (4.4)	750 (3.3)
#5 (15.9)	1	8 (203)	24 (610)	18 (457)	18 (457)	•	•	1,000 (4.4)	750 (3.3)
#6 (19.1)	1	8 (203)	24 (610)	18 (457)	18 (457)	•	•	1,000 (4.4)	750 (3.3)
Configuration B (Simpson Strong-Tie ATS or ATSP Screen Tube Required)									
3/4 (19.1)	1	13 (330)	16 (406)	18 (457)	24 (610)	1,200 (5.3)	1,200 (5.3)	1,000 (4.4)	750 (3.3)
Configuration C (Simpson Strong-Tie ATS Screen Tube and AST Steel Sleeve Required)									
5/8 (15.9)	1	**	24 (610)	18 (457)	18 (457)	1,200 (5.3)	1,200 (5.3)	1,000 (4.4)	750 (3.3)

1. Threaded rods must comply with ASTM F1554 Grade 36 minimum.
2. All holes are drilled with a 1" diameter carbide-tipped drill bit with the drill set in the rotation-only mode.
3. The unreinforced brick walls must have a minimum thickness of 13 inches (three wythes of brick).
4. The allowable load is applicable only where in-place shear tests indicate minimum net mortar strength of 50 psi.
5. The allowable load for Configuration B and C anchors subjected to a combined tension and shear load is determined by assuming a straight-line relationship between allowable tension and shear.
6. The anchors installed in unreinforced brick walls are limited to resisting seismic or wind forces only.
7. Configuration A has a straight threaded rod or rebar embedded 8 inches into the wall with a 3/8" diameter by 8-inch long screen tube (part # ATS758 or ATS758P). This configuration is designed to resist shear loads only.
8. Configuration B has a 3/4" threaded rod bent and installed at a 22.5-degree angle and installed 13 inches into the wall, to within 1-inch (maximum) of the exterior wall surface. This configuration is designed to resist tension and shear loads. The pre-bent threaded rod is installed with a 3/8" diameter by 13-inch long screen tube (part # ATS7513 or ATS7513P).
9. Configuration C is designed to resist tension and shear forces. It consists of a 5/8" diameter, ASTM F1554 Grade 36 threaded rod and an 8" long steel sleeve (part # AST800) and a 3/8" diameter by 8-inch long screen tube (part # ATS758). The steel sleeve has a plastic plug in one end. A 6" by 6" by 3/8" thick ASTM A 36 steel plate is located on the back face of the wall.
10. Special inspection requirements are determined by local jurisdiction and must be confirmed by the local building official.
11. Refer to in-service temperature sensitivity chart for allowable load adjustment for temperature.

*See page 13 for explanation of the load table icons

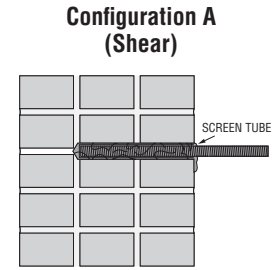

Configuration A (Shear)

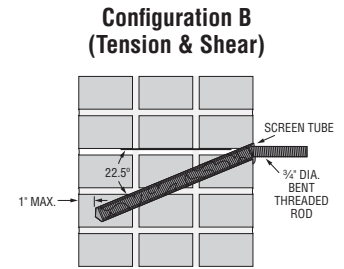

Configuration B (Tension & Shear)

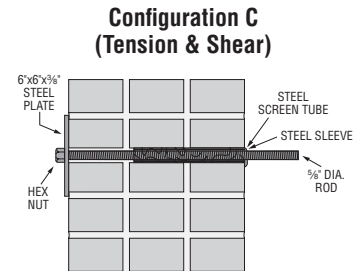

Configuration C (Tension & Shear)

Acrylic Adhesive

C-SAS-2012 © 2012 Simpson Strong-Tie Company Inc.

Tension and Shear Loads for Threaded Rod Anchors in Lightweight, Medium-Weight and Normal-Weight Hollow CMU

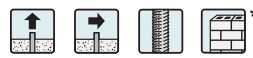

Rod Dia. in. (mm)	Drill Bit Dia. in.	Embed. Depth in. (mm)	Critical Edge Dist. in. (mm)	Critical Spacing Dist. in. (mm)	8-inch Hollow CMU Allowable Loads Based on CMU Strength			
					Tension		Shear	
					Ultimate lbs. (kN)	Allowable lbs. (kN)	Ultimate lbs. (kN)	Allowable lbs. (kN)
Anchor Installed in Face Shell w/Simpson Strong-Tie ATSP (Plastic) Screen Tube								
3/8 (9.5)	9/16	3 (76.2)	12 (305)	8 (203)	1,545 (6.9)	310 (1.4)	1,385 (6.2)	275 (1.2)
1/2 (12.7)	3/4	3 (76.2)	12 (305)	8 (203)	1,510 (6.7)	300 (1.3)	1,305 (5.8)	260 (1.2)
5/8 (15.9)	7/8	3 (76.2)	12 (305)	8 (203)	1,590 (7.1)	320 (1.4)	1,345 (6.0)	270 (1.2)

1. Threaded rods must comply with ASTM F1554 Grade 36 minimum.
2. The tabulated allowable loads are based on a safety factor of 5.0 for installations under the IBC and IRC.
3. Edge distances may be reduced to 4" with a corresponding 37% reduction in tension capacity. Shear capacity is unaffected.
4. Values for 8-inch wide, lightweight, medium-weight and normal-weight concrete masonry units with min. compressive strength of 1,900 psi and 1 1/4" thick face shell.
5. Embedment depth is measured from the outside face of the concrete masonry unit.
6. Refer to in-service temperature sensitivity chart for allowable load adjustment for temperature.
7. Allowable loads may not be increased for short-term loading due to wind or seismic forces. Wall design must satisfy applicable design standards and be capable of withstanding applied loads.
8. Set drill to rotation only mode when drilling into hollow CMU.

*See page 13 for explanation of the load table icons

- Installation Instructions for Configuration C:**
1. Drill hole perpendicular to the wall to a depth of 8" with a 1" diameter carbide-tipped drill bit (rotation only mode).
 2. Clean hole with oil-free compressed air and a nylon brush.
 3. Fill 8" steel screen tube with mixed adhesive and insert into hole.
 4. Insert steel sleeve slowly into screen tube (adhesive will displace).
 5. Allow adhesive to cure (see cure schedule).
 6. Drill through plastic plug in (inside) end of steel sleeve with 5/8" bit.
 7. Drill completely through the wall with 5/8" carbide tipped concrete drill bit (rotation mode only).
 8. Insert 5/8" rod through hole and attach metal plate and nut.

AT Technical Information

Acrylic Adhesive

**Load Adjustment Factors for AT Adhesive in Normal-Weight Concrete:
Edge Distance, Tension Load**

How to use these charts:

1. The following tables are for reduced edge distance.
2. Locate the anchor size to be used for either a tension and/or shear load application.
3. Locate the embedment (E) at which the anchor is to be installed.
4. Locate the edge distance (C_{act}) at which the anchor is to be installed.
5. The load-adjustment factor (f_c) is the intersection of the row and column.
6. Multiply the allowable load by the applicable load-adjustment factor.
7. Reduction factors for multiple edges are multiplied together.
8. Adjustment factors do not apply to allowable steel strength values.
9. Adjustment factors are to be applied to allowable tension load based on bond strength values only.

Edge Distance Tension (f_c)



Edge Dist. C_{act} (in.)	Dia.	3/8			1/2			5/8			3/4			
	Rebar	#3			#4			#5			#6			
	E	1 3/4	3 1/2	4 1/2	2 1/8	4 1/4	6	7 1/2	2 1/2	5 1/2	9 3/8	3 3/8	6 3/4	11 1/4
	C_{cr}	2 1/8	5 1/4	6 3/8	3 3/16	6 3/8	9	11 1/4	3 3/8	7 1/2	14 1/8	5 1/8	10 1/8	16 3/8
	C_{min}	1 3/4	1 3/4	1 3/4	1 3/4	1 3/4	1 3/4	1 3/4	1 3/4	1 3/4	1 3/4	1 3/4	1 3/4	1 3/4
	f_{cmin}	0.59	0.59	0.65	0.50	0.50	0.65	0.65	0.50	0.50	0.61	0.50	0.50	0.56
1 3/4		0.59	0.59	0.65	0.50	0.50	0.65	0.65	0.50	0.50	0.61	0.50	0.50	0.56
2		0.71	0.62	0.67	0.59	0.53	0.66	0.66	0.56	0.52	0.62	0.54	0.51	0.57
3		1.00	0.74	0.74	0.93	0.64	0.71	0.70	0.81	0.61	0.65	0.69	0.57	0.60
4			0.85	0.81	1.00	0.74	0.76	0.73	1.00	0.70	0.68	0.84	0.63	0.63
5			0.97	0.88		0.85	0.81	0.77		0.78	0.71	0.99	0.69	0.65
6			1.00	0.95		0.96	0.86	0.81		0.87	0.74	1.00	0.75	0.68
7				1.00		1.00	0.90	0.84		0.96	0.78		0.81	0.71
8							0.95	0.88		1.00	0.81		0.87	0.74
9							1.00	0.92			0.84		0.93	0.77
10								0.95			0.87		0.99	0.80
11								0.99			0.90		1.00	0.83
12								1.00			0.93			0.86
13											0.96			0.89
14											1.00			0.92
15														0.95
16														0.97
17														1.00

See Notes Below

Edge Distance Tension (f_c) (cont'd)



Edge Dist. C_{act} (in.)	Dia.	7/8			1			1 1/8			1 1/4			
	Rebar	#7			#8			#9			#10			
	E	3 3/8	7 3/4	13 1/8	4 1/2	9	15	5 1/8	10 1/8	16 3/8	5 3/8	11 1/4	18 3/4	20 3/8
	C_{cr}	5 13/16	11 1/8	19 3/8	6 3/8	13 1/2	22 1/2	7 3/4	15 1/4	25 3/8	8 3/8	16 3/8	28 1/8	31
	C_{min}	1 3/4	1 3/4	1 3/4	1 3/4	1 3/4	1 3/4	2 3/4	2 3/4	2 3/4	2 3/4	2 3/4	2 3/4	2 3/4
	f_{cmin}	0.49	0.49	0.52	0.44	0.44	0.39	0.47	0.47	0.43	0.47	0.47	0.43	0.43
1 3/4		0.49	0.49	0.52	0.44	0.44	0.39							
2 3/4		0.62	0.54	0.55	0.55	0.49	0.42	0.47	0.47	0.43	0.47	0.47	0.43	0.43
4		0.77	0.61	0.58	0.69	0.55	0.46	0.60	0.52	0.46	0.59	0.52	0.46	0.46
6		1.00	0.71	0.63	0.92	0.64	0.51	0.81	0.61	0.51	0.77	0.59	0.50	0.50
8			0.81	0.69	1.00	0.74	0.57	1.00	0.69	0.56	0.96	0.67	0.55	0.54
10			0.92	0.74		0.83	0.63		0.78	0.61	1.00	0.74	0.59	0.58
12			1.00	0.80		0.93	0.69		0.86	0.66		0.82	0.64	0.62
14				0.85		1.00	0.75		0.95	0.71		0.89	0.68	0.66
16				0.90			0.81		1.00	0.76		0.97	0.73	0.70
18				0.96			0.87			0.81		1.00	0.77	0.74
20				1.00			0.93			0.86			0.82	0.78
22							0.99			0.91			0.86	0.82
24							1.00			0.97			0.91	0.86
26										1.00			0.95	0.90
28													1.00	0.94
30														0.98
32														1.00

1. E = Embedment depth (inches).
2. C_{act} = actual edge distance at which anchor is installed (inches).
3. C_{cr} = critical edge distance for 100% load (inches).
4. C_{min} = minimum edge distance for reduced load (inches).
5. f_c = adjustment factor for allowable load at actual edge distance.
6. f_{ccr} = adjustment factor for allowable load at critical edge distance. f_{ccr} is always = 1.00.
7. f_{cmin} = adjustment factor for allowable load at minimum edge distance.
8. $f_c = f_{cmin} + [(1 - f_{cmin}) (C_{act} - C_{min}) / (C_{cr} - C_{min})]$.

*See page 13 for an explanation of the load table icons

*See page 13 for an explanation of the load table icons

AT Technical Information

Acrylic Adhesive

**Load Adjustment Factors for AT Adhesive in Normal-Weight Concrete:
Edge Distance, Shear Load**

How to use these charts:

- The following tables are for reduced edge distance.
- Locate the anchor size to be used for either a tension and/or shear load application.
- Locate the embedment (E) at which the anchor is to be installed.
- Locate the edge distance (C_{act}) at which the anchor is to be installed.
- The load-adjustment factor (f_c) is the intersection of the row and column.
- Multiply the allowable load by the applicable load-adjustment factor.
- Reduction factors for multiple edges are multiplied together.
- Adjustment factors do not apply to allowable steel strength values.
- Adjustment factors are to be applied to allowable shear load based on concrete edge distance values only.

Edge Distance Shear (f_c)

Edge Dist. C_{act} (in.)	Dia.	$\frac{3}{8}$				$\frac{1}{2}$				$\frac{5}{8}$				$\frac{3}{4}$				#6			
	Rebar	#3				#4				#5				#6							
	E	1 ¼	3 ½	4 ½	3 ½	4 ½	2 ½	4 ¼	6	4 ¼	7 ½	2 ½	5 ½	9 ½	5 ½	9 ½	3 ¾	6 ¾	11 ¼	6 ¾	11 ¼
	C_{cr}	5 ¼	5 ¼	5 ¼	6	6	6 ½	6 ½	6 ½	8	8	7 ½	7 ½	7 ½	10	10	10 ½	10 ½	10 ½	12	12
C_{min}	1 ¼	1 ¼	1 ¼	1 ¼	1 ¼	1 ¼	1 ¼	1 ¼	1 ¼	1 ¼	1 ¼	1 ¼	1 ¼	1 ¼	1 ¼	1 ¼	1 ¼	1 ¼	1 ¼	1 ¼	
f_{cmin}	0.40	0.35	0.39	0.19	0.39	0.18	0.15	0.25	0.16	0.25	0.12	0.11	0.14	0.10	0.14	0.10	0.11	0.14	0.10	0.14	
1 ¼		0.40	0.35	0.39	0.19	0.39	0.18	0.15	0.25	0.16	0.25	0.12	0.11	0.14	0.10	0.14	0.10	0.11	0.14	0.10	0.14
2 ¼		0.57	0.54	0.56	0.38	0.53	0.36	0.33	0.41	0.29	0.37	0.27	0.26	0.29	0.21	0.24	0.21	0.22	0.24	0.19	0.22
3		0.61	0.58	0.61	0.43	0.57	0.40	0.38	0.45	0.33	0.40	0.31	0.30	0.33	0.24	0.27	0.23	0.24	0.27	0.21	0.24
3 ½		0.70	0.68	0.70	0.52	0.64	0.49	0.47	0.53	0.40	0.46	0.39	0.38	0.40	0.29	0.32	0.29	0.30	0.32	0.25	0.29
4		0.79	0.77	0.78	0.62	0.71	0.58	0.56	0.61	0.46	0.52	0.46	0.46	0.48	0.35	0.37	0.34	0.35	0.37	0.30	0.33
4 ½		0.87	0.86	0.87	0.71	0.78	0.67	0.66	0.70	0.53	0.58	0.54	0.54	0.55	0.40	0.43	0.40	0.40	0.42	0.34	0.37
5		0.96	0.95	0.96	0.81	0.86	0.76	0.75	0.78	0.60	0.64	0.62	0.61	0.63	0.45	0.48	0.45	0.46	0.47	0.39	0.41
5 ½		1.00	1.00	1.00	0.90	0.93	0.84	0.84	0.86	0.66	0.70	0.69	0.69	0.70	0.51	0.53	0.50	0.51	0.53	0.43	0.45
6					1.00	1.00	0.93	0.93	0.94	0.73	0.76	0.77	0.77	0.78	0.56	0.58	0.56	0.56	0.58	0.47	0.50
6 ½							1.00	1.00	1.00	0.80	0.82	0.85	0.85	0.85	0.62	0.64	0.61	0.61	0.63	0.52	0.54
7										0.87	0.88	0.92	0.92	0.93	0.67	0.69	0.66	0.67	0.68	0.56	0.58
7 ½										0.93	0.94	1.00	1.00	1.00	0.73	0.74	0.72	0.72	0.73	0.60	0.62
8										1.00	1.00				0.78	0.79	0.77	0.77	0.78	0.65	0.66
8 ½															0.84	0.84	0.83	0.83	0.83	0.69	0.71
9															0.89	0.90	0.88	0.88	0.88	0.74	0.75
9 ½															0.95	0.95	0.93	0.93	0.94	0.78	0.79
10															1.00	1.00	0.99	0.99	0.99	0.82	0.83
10 ½																	1.00	1.00	1.00	0.87	0.87
11																				0.91	0.92
11 ½																				0.96	0.96
12																				1.00	1.00



*See page 13 for an explanation of the load table icons

See Notes Below

Edge Distance Shear (f_c) (cont'd)

Edge Dist. C_{act} (in.)	Dia.	$\frac{7}{8}$				1				1 ½				1 ¾			
	Rebar	#7				#8				#9				#10			
	E	3 ¾	7 ¾	13 ¾	7 ¾	13 ¾	4 ½	9	15	9	15	5 ½	10 ½	16 ½	5 ½	11 ¼	18 ¼
	C_{cr}	11 ¾	11 ¾	11 ¾	14	14	13 ½	13 ½	13 ½	16	16	15 ¼	15 ¼	15 ¼	16 ¾	16 ¾	16 ¾
C_{min}	1 ¼	1 ¼	1 ¼	1 ¼	1 ¼	1 ¼	1 ¼	1 ¼	1 ¼	1 ¼	2 ¼	2 ¼	2 ¼	2 ¼	2 ¼	2 ¼	
f_{cmin}	0.09	0.08	0.09	0.09	0.09	0.08	0.08	0.09	0.08	0.09	0.14	0.12	0.12	0.14	0.12	0.12	
1 ¼		0.09	0.08	0.09	0.09	0.09	0.08	0.08	0.09	0.08	0.09	0.14	0.12	0.12	0.14	0.12	0.12
2 ¼		0.18	0.17	0.18	0.16	0.16	0.16	0.17	0.14	0.15	0.14	0.12	0.12	0.14	0.12	0.12	
3		0.21	0.20	0.21	0.18	0.18	0.18	0.19	0.16	0.17	0.16	0.14	0.14	0.16	0.14	0.14	
4		0.30	0.29	0.30	0.26	0.26	0.26	0.26	0.23	0.23	0.23	0.21	0.21	0.22	0.20	0.20	
5		0.39	0.38	0.39	0.33	0.33	0.33	0.33	0.34	0.29	0.30	0.29	0.28	0.28	0.26	0.26	
6		0.48	0.48	0.48	0.41	0.41	0.41	0.41	0.42	0.35	0.36	0.36	0.35	0.35	0.34	0.32	
7		0.57	0.57	0.57	0.48	0.48	0.49	0.49	0.50	0.42	0.43	0.43	0.42	0.42	0.40	0.38	
8		0.67	0.66	0.67	0.55	0.55	0.57	0.57	0.57	0.48	0.49	0.50	0.49	0.49	0.46	0.45	
9		0.76	0.76	0.76	0.63	0.63	0.65	0.65	0.65	0.55	0.55	0.57	0.56	0.56	0.52	0.51	
10		0.85	0.85	0.85	0.70	0.70	0.73	0.73	0.73	0.61	0.62	0.64	0.63	0.63	0.58	0.57	
11		0.94	0.94	0.94	0.78	0.78	0.80	0.80	0.81	0.68	0.68	0.71	0.70	0.70	0.64	0.63	
12		1.00	1.00	1.00	0.85	0.85	0.88	0.88	0.88	0.74	0.74	0.78	0.77	0.77	0.70	0.70	
13					0.93	0.93	0.96	0.96	0.96	0.81	0.81	0.85	0.84	0.84	0.76	0.76	
14					1.00	1.00	1.00	1.00	1.00	0.87	0.87	0.91	0.91	0.91	0.82	0.82	
15										0.94	0.94	0.98	0.98	0.98	0.89	0.88	
16										1.00	1.00	1.00	1.00	1.00	0.95	0.95	
17															1.00	1.00	



*See page 13 for an explanation of the load table icons

- E = Embedment depth (inches).
- C_{act} = actual edge distance at which anchor is installed (inches).
- C_{cr} = critical edge distance for 100% load (inches).
- C_{min} = minimum edge distance for reduced load (inches).
- f_c = adjustment factor for allowable load at actual edge distance.
- f_{ccr} = adjustment factor for allowable load at critical edge distance. f_{ccr} is always = 1.00.
- f_{cmin} = adjustment factor for allowable load at minimum edge distance.
- $f_c = f_{cmin} + [(1 - f_{cmin}) (C_{act} - C_{min}) / (C_{cr} - C_{min})]$.

AT Technical Information

Acrylic Adhesive

Load Adjustment Factors for AT Adhesive in Normal-Weight Concrete: Spacing, Tension Load

How to use these charts:

1. The following tables are for reduced spacing.
2. Locate the anchor size to be used for either a tension and/or shear load application.
3. Locate the embedment (E) at which the anchor is to be installed.
4. Locate the spacing (S_{act}) at which the anchor is to be installed.
5. The load-adjustment factor (f_s) is the intersection of the row and column.
6. Multiply the allowable load by the applicable load-adjustment factor.
7. Reduction factors for multiple spacings are multiplied together.
8. Adjustment factors do not apply to allowable steel strength values.
9. Adjustment factors are to be applied to allowable tension load based on bond strength values only.

Spacing Tension (f_s)

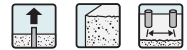

S_{act} (in.)	Dia. Rebar	3/8"			1/2"			5/8"			3/4"			
		#3			#4			#5			#6			
	E	1 3/4	3 1/2	4 1/2	2 1/8	4 1/4	6	7 1/2	2 1/2	5 1/2	9 3/8	3 3/8	6 3/4	11 1/4
S_{cr}	7	6 1/8	18	8 1/2	7 1/2	24	30	10	9 5/8	37 1/2	13 1/2	11 7/8	45	
S_{min}	7 7/8	1 3/4	2 1/4	1 1/8	2 1/8	3	3 3/4	1 1/4	2 3/4	4 3/4	1 3/4	3 3/8	5 5/8	
f_{smin}	0.57	0.58	0.80	0.57	0.58	0.80	0.80	0.57	0.58	0.80	0.57	0.58	0.80	
7/8		0.57												
1		0.58												
1 1/2		0.61			0.59			0.58						
2		0.65	0.60		0.62			0.61			0.58			
2 1/2		0.68	0.64	0.80	0.65	0.61		0.63			0.60			
3		0.72	0.68	0.81	0.67	0.64	0.80		0.66	0.59		0.61		
3 1/2		0.75	0.72	0.82	0.70	0.68	0.80		0.68	0.62		0.63	0.59	
4		0.79	0.76	0.82	0.73	0.71	0.81	0.80	0.71	0.65		0.65	0.61	
5		0.86	0.84	0.83	0.78	0.79	0.82	0.81	0.75	0.71	0.80	0.68	0.66	
6		0.93	0.92	0.85	0.84	0.86	0.83	0.82	0.80	0.77	0.81	0.72	0.71	0.80
7		1.00	1.00	0.86	0.89	0.93	0.84	0.82	0.85	0.83	0.81	0.75	0.76	0.81
8				0.87	0.95	1.00	0.85	0.83	0.90	0.88	0.82	0.79	0.81	0.81
9				0.89	1.00		0.86	0.84	0.95	0.94	0.82	0.82	0.85	0.82
10				0.90			0.87	0.84	1.00	1.00	0.83	0.86	0.90	0.82
12				0.92			0.89	0.86			0.84	0.93	1.00	0.83
14				0.95			0.90	0.87			0.85	1.00		0.84
16				0.97			0.92	0.89			0.86			0.85
18				1.00			0.94	0.90			0.88			0.86
20							0.96	0.92			0.89			0.87
24							1.00	0.94			0.91			0.89
28								0.97			0.93			0.91
32								1.00			0.95			0.93
36											0.98			0.95
40											1.00			0.97
45														1.00

*See page 13 for an explanation of the load table icons

7/8" - 1 1/4"
Diameters
on next
page



1. E = Embedment depth (inches).
2. S_{act} = actual spacing distance at which anchors are installed (inches).
3. S_{cr} = critical spacing distance for 100% load (inches).
4. S_{min} = minimum spacing distance for reduced load (inches).
5. f_s = adjustment factor for allowable load at actual spacing distance.
6. f_{scr} = adjustment factor for allowable load at critical spacing distance. f_{scr} is always = 1.00.
7. f_{smin} = adjustment factor for allowable load at minimum spacing distance.
8. $f_s = f_{smin} + [(1 - f_{smin}) (S_{act} - S_{min}) / (S_{cr} - S_{min})]$.

AT Technical Information



Spacing Tension (f_s) (cont'd)

S_{act} (in.)	Di.	¾			1			1½			1¾			
	Rebar	#7			#8			#9			#10			
	E	3¾	7¾	13¾	4½	9	15	5½	10½	16½	5¾	11¾	18¾	
	S_{cr}	15½	13¾	52½	18	15¾	60	20½	17¾	67½	22½	19¾	75	
	S_{min}	2	3¾	6¾	2¼	4½	7½	2¾	5¾	8½	2¾	5¾	9¾	
f_{smin}	0.57	0.58	0.80	0.57	0.58	0.80	0.57	0.58	0.80	0.57	0.58	0.80		
2		0.57												
3		0.60			0.59			0.58			0.57			
4		0.63	0.59		0.62			0.60			0.59			
5		0.67	0.63		0.65	0.60		0.63			0.62			
6		0.70	0.67		0.67	0.64		0.65	0.61		0.64	0.59		
8		0.76	0.76	0.81	0.73	0.71	0.80	0.70	0.68		0.68	0.65		
10		0.82	0.84	0.81	0.78	0.79	0.81	0.75	0.74	0.81	0.73	0.71	0.80	
12		0.89	0.93	0.82	0.84	0.86	0.82	0.80	0.81	0.81	0.77	0.77	0.81	0.80
14		0.95	1.00	0.83	0.89	0.93	0.82	0.84	0.88	0.82	0.81	0.83	0.81	0.81
16		1.00		0.84	0.95	1.00	0.83	0.89	0.94	0.83	0.86	0.89	0.82	0.82
20				0.86	1.00		0.85	0.99	1.00	0.84	0.95	1.00	0.83	0.83
24				0.88			0.86	1.00		0.85	1.00		0.84	0.84
28				0.89			0.88			0.87			0.86	0.85
32				0.91			0.89			0.88			0.87	0.86
36				0.93			0.91			0.89			0.88	0.87
40				0.95			0.92			0.91			0.89	0.88
50				0.99			0.96			0.94			0.92	0.91
60				1.00			1.00			0.97			0.95	0.94
70										1.00			0.98	0.97
80													1.00	0.99
83														1.00

*See page 13 for an explanation of the load table icons

See notes on previous page

Acrylic Adhesive

Load Adjustment Factors for AT Adhesive in Normal-Weight Concrete: Spacing, Shear Load

How to use these charts:

1. The following tables are for reduced spacing.
2. Locate the anchor size to be used for either a tension and/or shear load application.
3. Locate the embedment (E) at which the anchor is to be installed.
4. Locate the spacing (S_{act}) at which the anchor is to be installed.
5. The load-adjustment factor (f_s) is the intersection of the row and column.
6. Multiply the allowable load by the applicable load-adjustment factor.
7. Reduction factors for multiple spacings are multiplied together.
8. Adjustment factors do not apply to allowable steel strength values.
9. Adjustment factors are to be applied to allowable shear load based on concrete edge distance values only.

Spacing Shear (f_s)



S_{act} (in.)	Di.	¾		½		5/8		¾		7/8		1		1½		1¾	
	Rebar	#3		#4		#5		#6		#7		#8		#9		#10	
	E	1¾	3½	2¾	4¼	2½	5½	3¾	6¼	3¾	7¼	4½	9	5¾	10½	5¾	11¼
	S_{cr}	2¾	5¼	3¼	6¾	3¼	8¼	5¾	10½	5¾	11¾	6¼	13½	7¼	15¼	8½	16¾
	S_{min}	7/8	1¾	1¾	2¾	1¾	2¾	1¾	3¾	2	3¾	2¼	4½	2¾	5¾	2¾	5¾
f_{smin}	0.90	0.83	0.90	0.83	0.90	0.83	0.90	0.83	0.90	0.83	0.90	0.83	0.90	0.83	0.90	0.83	
7/8		0.90															
1		0.91															
1½		0.94		0.92		0.91											
2		0.96	0.84	0.94		0.93		0.91		0.90							
2½		0.99	0.87	0.96	0.85	0.95		0.92		0.91		0.91					
3		1.00	0.89	0.99	0.87	0.97	0.84	0.94		0.93		0.92		0.91		0.90	
3½			0.92	1.00	0.89	0.99	0.85	0.95	0.83	0.94		0.93		0.92		0.91	
4			0.94		0.91	1.00	0.87	0.97	0.85	0.95	0.83	0.94		0.93		0.92	
5			0.99		0.95		0.90	1.00	0.87	0.98	0.85	0.96	0.84	0.95		0.94	
6			1.00		0.99		0.93		0.90	1.00	0.88	0.98	0.86	0.97	0.84	0.96	0.84
7					1.00		0.96		0.92		0.90	1.00	0.88	0.99	0.86	0.97	0.85
8							0.99		0.95		0.92		0.90	1.00	0.88	0.99	0.87
9							1.00		0.97		0.94		0.92		0.90	1.00	0.88
10									1.00		0.96		0.93		0.91		0.90
12											1.00		0.97		0.95		0.93
14													1.00		0.98		0.96
16															1.00		0.99
17																	1.00

1. E = Embedment depth (inches).
2. S_{act} = actual spacing distance at which anchors are installed (inches).
3. S_{cr} = critical spacing distance for 100% load (inches).
4. S_{min} = minimum spacing distance for reduced load (inches).
5. f_s = adjustment factor for allowable load at actual spacing distance.
6. f_{scr} = adjustment factor for allowable load at critical spacing distance. f_{scr} is always = 1.00.
7. f_{smin} = adjustment factor for allowable load at minimum spacing distance.
8. $f_s = f_{smin} + [(1 - f_{smin})(S_{act} - S_{min}) / (S_{cr} - S_{min})]$.

AT Technical Information

Acrylic Adhesive

Load Adjustment Factors for AT Adhesive in Sand-Lightweight Concrete: Edge Distance, Tension and Shear Loads

How to use these charts:

1. The following tables are for reduced edge distance only.
2. Locate the anchor size to be used for either a tension and/or shear load application.
3. Locate the embedment (E) at which the anchor is to be installed.
4. Locate the edge distance (C_{act}) at which the anchor is to be installed.
5. The load-adjustment factor (f_c) is the intersection of the row and column.
6. Multiply the allowable load by the applicable load-adjustment factor.
7. Reduction factors for multiple edges are multiplied together.
8. Adjustment factors do not apply to allowable steel strength values.
9. Adjustment factors are to be applied to allowable tension load based on bond strength values or allowable shear load based on concrete edge distance values only.

Edge Distance Tension (f_c)   

Edge Dist. C_{act} (in.)	Dia.	3/8		1/2		5/8	
	E	1 1/4	3 1/2	2 1/8	4 1/4	2 1/2	5
C_{cr}		2 5/8	5 1/4	3 3/8	6 3/8	3 3/4	7 1/2
C_{min}		1 1/4	1 3/4	1 1/4	1 3/4	1 1/4	1 3/4
f_{cmin}		0.59	0.59	0.50	0.50	0.50	0.50
1 3/4		0.59	0.59	0.50	0.50	0.50	0.50
2		0.71	0.62	0.59	0.53	0.56	0.52
2 1/4		0.82	0.65	0.68	0.55	0.63	0.54
2 1/2		0.94	0.68	0.77	0.58	0.69	0.57
2 3/4		1.00	0.71	0.86	0.61	0.75	0.59
3			0.74	0.95	0.64	0.81	0.61
3 1/4			0.77	1.00	0.66	0.88	0.63
3 1/2			0.80		0.69	0.94	0.65
3 3/4			0.82		0.72	1.00	0.67
4			0.85		0.74		0.70
4 1/4			0.88		0.77		0.72
4 1/2			0.91		0.80		0.74
4 3/4			0.94		0.82		0.76
5			0.97		0.85		0.78
5 1/4			1.00		0.88		0.80
5 1/2					0.91		0.83
5 3/4					0.93		0.85
6					0.96		0.87
6 1/4					0.99		0.89
6 1/2					1.00		0.91
6 3/4							0.93
7							0.96
7 1/4							0.98
7 1/2							1.00

Edge Distance Shear (f_c)   

Edge Dist. C_{act} (in.)	Dia.	3/8		1/2		5/8	
	E	1 1/4	3 1/2	2 1/8	4 1/4	2 1/2	5
C_{cr}		2 5/8	5 1/4	3 3/8	6 3/8	3 3/4	7 1/2
C_{min}		1 1/4	1 3/4	1 1/4	1 3/4	1 1/4	1 3/4
f_{cmin}		0.40	0.35	0.18	0.15	0.12	0.11
1 3/4		0.40	0.35	0.18	0.15	0.12	0.11
2		0.57	0.40	0.33	0.20	0.23	0.15
2 1/4		0.74	0.44	0.48	0.24	0.34	0.19
2 1/2		0.91	0.49	0.63	0.29	0.45	0.23
2 3/4		1.00	0.54	0.78	0.33	0.56	0.26
3			0.58	0.93	0.38	0.67	0.30
3 1/4			0.63	1.00	0.43	0.78	0.34
3 1/2			0.68		0.47	0.89	0.38
3 3/4			0.72		0.52	1.00	0.42
4			0.77		0.56		0.46
4 1/4			0.81		0.61		0.50
4 1/2			0.86		0.66		0.54
4 3/4			0.91		0.70		0.57
5			0.95		0.75		0.61
5 1/4			1.00		0.79		0.65
5 1/2					0.84		0.69
5 3/4					0.89		0.73
6					0.93		0.77
6 1/4					0.98		0.81
6 1/2					1.00		0.85
6 3/4							0.88
7							0.92
7 1/4							0.96
7 1/2							1.00

1. E = Embedment depth (inches).
2. C_{act} = actual edge distance at which anchor is installed (inches).
3. C_{cr} = critical edge distance for 100% load (inches).
4. C_{min} = minimum edge distance for reduced load (inches).
5. f_c = adjustment factor for allowable load at actual edge distance.
6. $f_{c_{cr}}$ = adjustment factor for allowable load at critical edge distance. $f_{c_{cr}}$ is always = 1.00.
7. $f_{c_{min}}$ = adjustment factor for allowable load at minimum edge distance.
8. $f_c = f_{c_{min}} + [(1 - f_{c_{min}}) (C_{act} - C_{min}) / (C_{cr} - C_{min})]$.

*See page 13 for an explanation of the load table icons

Estimating Guide for 9.6 oz Cartridge using Threaded Rod - Installations per Cartridge

Rod Dia. (in.)	Drill Bit Dia. (in.)	THREADED ROD IN SOLID BASE MATERIAL HOLE DEPTH (inches)																		
		2	3	4	5	6	7	8	9	10	11	12	13	14	15	16	17	18	19	20
3/8	7/16	73	49	36	29	24	21	18	16	15	13	12	11	10	10	9	9	8	8	7
3/8	1/2	46	31	23	18	15	13	12	10	9	8	8	7	7	6	6	5	5	5	5
1/2	9/16	53	35	27	21	18	15	13	12	11	10	9	8	8	7	7	6	6	6	5
1/2	5/8	33	22	17	13	11	10	8	7	7	6	6	5	5	4	4	4	4	4	3
5/8	11/16	39	26	19	16	13	11	10	9	8	7	6	6	6	5	5	5	4	4	4
5/8	3/4	26	17	13	10	9	7	7	6	5	5	4	4	4	3	3	3	3	3	3
3/4	13/16	31	21	16	12	10	9	8	7	6	6	5	5	4	4	4	4	3	3	3
3/4	7/8	21	14	11	8	7	6	5	5	4	4	4	3	3	3	3	2	2	2	2
7/8	15/16	25	17	12	10	8	7	6	6	5	5	4	4	4	3	3	3	3	3	2
7/8	1	18	12	9	7	6	5	4	4	4	3	3	3	3	2	2	2	2	2	2
1	1 1/16	20	14	10	8	7	6	5	5	4	4	3	3	3	3	3	2	2	2	2
1	1 1/8	15	10	7	6	5	4	4	3	3	3	2	2	2	2	2	2	2	2	1
1 1/8	1 3/16	17	11	8	7	6	5	4	4	3	3	3	3	2	2	2	2	2	2	2
1 1/8	1 1/4	13	8	6	5	4	4	3	3	3	2	2	2	2	2	2	1	1	1	1
1 1/4	1 5/16	15	10	7	6	5	4	4	3	3	3	2	2	2	2	2	2	2	2	1
1 1/4	1 3/8	11	8	6	5	4	3	3	3	3	2	2	2	2	2	1	1	1	1	1

Estimating Guide for 9.6 oz Cartridge using Rebar - Installations per Cartridge

Rebar Size (no.)	Drill Bit Dia. (in.)	REBAR IN SOLID BASE MATERIAL HOLE DEPTH (inches)																		
		2	3	4	5	6	7	8	9	10	11	12	13	14	15	16	17	18	19	20
3	1/2	55	37	27	22	18	16	14	12	11	10	9	8	8	7	7	6	6	6	5
4	9/16	81	54	40	32	27	23	20	18	16	15	13	12	12	11	10	9	9	8	8
4	5/8	43	28	21	17	14	12	11	9	9	8	7	7	6	6	5	5	5	4	4
5	3/4	34	23	17	14	11	10	9	8	7	6	6	5	5	5	4	4	4	4	3
6	7/8	27	18	14	11	9	8	7	6	5	5	5	4	4	4	3	3	3	3	3
7	1	24	16	12	10	8	7	6	5	5	4	4	4	3	3	3	3	3	3	2
8	1 1/8	21	14	10	8	7	6	5	5	4	4	3	3	3	3	2	2	2	2	2
9	1 1/4	19	12	9	7	6	5	5	4	4	3	3	3	3	2	2	2	2	2	2
10	1 3/8	19	12	9	7	6	5	5	4	4	3	3	3	3	2	2	2	2	2	2
11	1 5/8	9	6	5	4	3	3	2	2	2	2	2	1	1	1	1	1	1	1	1

Estimating Guide for 9.6 oz Cartridge and Steel Screen Tubes - Installations per Cartridge

Rod Dia. (in.)	Drill Bit Dia. (in.)	THREADED ROD INSERTED IN SCREEN TUBE HOLE DEPTH (inches)																		
		3 1/2	4	4 1/2	5	5 1/2	6	6 1/2	7	7 1/2	8	9	10	11	12	13	14	15	16	17
3/8	9/16	20	18	16	14	13	12	11	10	9	9	8	7							
1/2	1 1/16	13	11	10	9	8	7	7	6	6	5	5	4							
5/8	7/8	7	6	5	5	4	4	3	3	3	3	2	2	2						
3/4	1	5	4	4	3	3	3	2	2	2	2	2	1	1	1	1	1	1	1	1

Estimating Guide for 9.6 oz Cartridge and Opti-Mesh Screen Tubes - Installations per Cartridge

Rod Dia. (in.)	Drill Bit Dia. (in.)	THREADED ROD INSERTED IN OPTI-MESH SCREEN TUBE HOLE DEPTH (inches)																						
		3 1/2	4	4 1/2	5	5 1/2	6	6 1/2	7	7 1/2	8	9	10	11	12	13	14	15	16	17	18	19	20	21
3/8	9/16	20	17	15	14	12	11	10	10	9	8	7	7											
1/2	1 1/16	11	9	8	7	7	6	5	5	5	4	4	3											
5/8	7/8	7	6	5	5	4	4	4	3	3	3	2	2	2	2									
3/4	1	5	4	4	3	3	3	3	2	2	2	2	1	2	1	1	1	1	1	1	1	1	1	1

Tables are estimations. Actual usage may vary depending on waste.

Note: Online adhesive cartridge quantity estimating tools are available by visiting www.strongtie.com

Estimating Guides for AT Anchoring Adhesive

Acrylic Adhesive

Estimating Guide for 12.5 oz. Cartridge using Threaded Rod – Installations per Cartridge

Rod Dia. (in.)	Drill Bit Dia. (in.)	THREADED ROD IN SOLID BASE MATERIAL HOLE DEPTH (inches)																		
		2	3	4	5	6	7	8	9	10	11	12	13	14	15	16	17	18	19	20
3/8	7/16	103	69	51	41	34	29	26	23	21	19	17	16	15	14	13	12	11	11	10
3/8	1/2	65	43	32	26	22	19	16	14	13	12	11	10	9	9	8	8	7	7	6
1/2	9/16	75	50	37	30	25	21	19	17	15	14	12	12	11	10	9	9	8	8	7
1/2	5/8	47	31	24	19	16	13	12	10	9	9	8	7	7	6	6	6	5	5	5
5/8	11/16	55	37	27	22	18	16	14	12	11	10	9	8	8	7	7	6	6	6	5
5/8	3/4	37	25	18	15	12	11	9	8	7	7	6	6	5	5	5	4	4	4	4
3/4	13/16	44	29	22	18	15	13	11	10	9	8	7	7	6	6	6	5	5	5	4
3/4	7/8	30	20	15	12	10	8	7	7	6	5	5	5	4	4	4	3	3	3	3
7/8	15/16	35	23	17	14	12	10	9	8	7	6	6	5	5	5	4	4	4	4	3
7/8	1	25	17	12	10	8	7	6	6	5	5	4	4	4	3	3	3	3	3	2
1	1 1/16	29	19	14	12	10	8	7	6	6	5	5	4	4	4	4	3	3	3	3
1	1 1/8	21	14	10	8	7	6	5	5	4	4	3	3	3	3	3	2	2	2	2
1 1/8	1 3/16	24	16	12	10	8	7	6	5	5	4	4	4	3	3	3	3	3	3	2
1 1/8	1 1/4	18	12	9	7	6	5	4	4	4	3	3	3	3	2	2	2	2	2	2
1 1/4	1 5/16	21	14	10	8	7	6	5	5	4	4	3	3	3	3	3	2	2	2	2
1 1/4	1 3/8	16	11	8	6	5	5	4	4	3	3	3	2	2	2	2	2	2	2	2

Estimating Guide for 12.5 oz. Cartridge using Rebar – Installations per Cartridge

Rebar Size (no.)	Drill Bit Dia. (in.)	REBAR IN SOLID BASE MATERIAL HOLE DEPTH (inches)																		
		2	3	4	5	6	7	8	9	10	11	12	13	14	15	16	17	18	19	20
3	1/2	77	52	39	31	26	22	19	17	15	14	13	12	11	10	10	9	9	8	8
4	9/16	114	76	57	45	38	32	28	25	23	21	19	17	16	15	14	13	13	12	11
4	5/8	60	40	30	24	20	17	15	13	12	11	10	9	9	8	8	7	7	6	6
5	3/4	48	32	24	19	16	14	12	11	10	9	8	7	7	6	6	6	5	5	5
6	7/8	39	26	19	16	13	11	10	9	8	7	6	6	6	5	5	5	4	4	4
7	1	34	23	17	14	11	10	8	8	7	6	6	5	5	5	4	4	4	4	3
8	1 1/8	29	19	15	12	10	8	7	6	6	5	5	4	4	4	4	3	3	3	3
9	1 1/4	26	17	13	10	9	7	7	6	5	5	4	4	4	3	3	3	3	3	3
10	1 3/8	26	18	13	11	9	8	7	6	5	5	4	4	4	4	3	3	3	3	3
11	1 5/8	13	9	7	5	4	4	3	3	3	2	2	2	2	2	2	2	1	1	1

Estimating Guide for 12.5 oz. Cartridge and Steel Screen Tubes – Installations per Cartridge

Rod Dia. (in.)	Drill Bit Dia. (in.)	THREADED ROD INSERTED IN SCREEN TUBE HOLE DEPTH (inches)																		
		3 1/2	4	4 1/2	5	5 1/2	6	6 1/2	7	7 1/2	8	9	10	11	12	13	14	15	16	17
3/8	9/16	29	25	23	20	18	17	16	15	14	13	11	10							
1/2	1 1/16	18	16	14	13	12	11	10	9	9	8	7	6							
5/8	7/8	10	9	8	7	7	6	6	5	5	4	4	3	3	3					
3/4	1	8	7	6	5	5	4	4	4	4	3	3	3	2	2	2	2	2	2	2

Estimating Guide for 12.5 oz. Cartridge and Plastic Screen Tubes – Installations per Cartridge

Rod Dia. (in.)	Drill Bit Dia. (in.)	THREADED ROD INSERTED IN SCREEN TUBE HOLE DEPTH (inches)																						
		3 1/2	4	4 1/2	5	5 1/2	6	6 1/2	7	7 1/2	8	9	10	11	12	13	14	15	16	17	18	19	20	21
3/8	9/16	34	30	26	24	22	20	18	17	16	15	13	12											
1/2	1 1/16	18	15	14	12	11	10	9	9	8	8	7	6											
5/8	7/8	12	11	9	8	8	7	6	6	6	5	5	4	4	4	3								
3/4	1	9	8	7	6	6	5	5	4	4	4	3	3	3	3	2	2	2	2	2	2	2	2	2

Tables are estimations. Actual usage may vary depending on waste.
Note: Online adhesive cartridge quantity estimating tools are available by visiting www.strongtie.com

Estimating Guides for AT Anchoring Adhesive

Acrylic Adhesive

Estimating Guide for 30 oz. Cartridge using Threaded Rod – Installations per Cartridge

Rod Dia. (in.)	Drill Bit Dia. (in.)	THREADED ROD IN SOLID BASE MATERIAL HOLE DEPTH (inches)																		
		2	3	4	5	6	7	8	9	10	11	12	13	14	15	16	17	18	19	20
3/8	7/16	237	158	119	95	79	68	59	53	47	43	40	37	34	32	30	28	26	25	24
3/8	1/2	150	100	75	60	50	43	37	33	30	27	25	23	21	20	19	18	17	16	15
1/2	9/16	173	115	86	69	58	49	43	38	35	31	29	27	25	23	22	20	19	18	17
1/2	5/8	109	73	54	44	36	31	27	24	22	20	18	17	16	15	14	13	12	11	11
5/8	11/16	127	84	63	51	42	36	32	28	25	23	21	19	18	17	16	15	14	13	13
5/8	3/4	85	57	43	34	28	24	21	19	17	15	14	13	12	11	11	10	9	9	9
3/4	13/16	102	68	51	41	34	29	25	23	20	18	17	16	15	14	13	12	11	11	10
3/4	7/8	68	46	34	27	23	20	17	15	14	12	11	11	10	9	9	8	8	7	7
7/8	15/16	81	54	40	32	27	23	20	18	16	15	13	12	12	11	10	9	9	8	8
7/8	1	58	38	29	23	19	16	14	13	12	10	10	9	8	8	7	7	6	6	6
1	1 1/16	66	44	33	27	22	19	17	15	13	12	11	10	9	9	8	8	7	7	7
1	1 1/8	47	32	24	19	16	14	12	11	9	9	8	7	7	6	6	6	5	5	5
1 1/8	1 3/16	55	37	27	22	18	16	14	12	11	10	9	8	8	7	7	6	6	6	5
1 1/8	1 1/4	41	27	20	16	14	12	10	9	8	7	7	6	6	5	5	5	5	4	4
1 1/4	1 5/16	48	32	24	19	16	14	12	11	10	9	8	7	7	6	6	6	5	5	5
1 1/4	1 3/8	37	25	18	15	12	11	9	8	7	7	6	6	5	5	5	4	4	4	4

Estimating Guide for 30 oz. Cartridge using Rebar – Installations per Cartridge

Rebar Size (no.)	Drill Bit Dia. (in.)	REBAR IN SOLID BASE MATERIAL HOLE DEPTH (inches)																		
		2	3	4	5	6	7	8	9	10	11	12	13	14	15	16	17	18	19	20
3	1/2	178	119	89	71	59	51	45	40	36	32	30	27	25	24	22	21	20	19	18
4	9/16	262	175	131	105	87	75	65	58	52	48	44	40	37	35	33	31	29	28	26
4	5/8	139	92	69	55	46	40	35	31	28	25	23	21	20	18	17	16	15	15	14
5	3/4	112	74	56	45	37	32	28	25	22	20	19	17	16	15	14	13	12	12	11
6	7/8	89	60	45	36	30	26	22	20	18	16	15	14	13	12	11	11	10	9	9
7	1	78	52	39	31	26	22	19	17	16	14	13	12	11	10	10	9	9	8	8
8	1 1/8	67	45	33	27	22	19	17	15	13	12	11	10	10	9	8	8	7	7	7
9	1 1/4	60	40	30	24	20	17	15	13	12	11	10	9	9	8	8	7	7	6	6
10	1 3/8	61	40	30	24	20	17	15	13	12	11	10	9	9	8	8	7	7	6	6
11	1 5/8	31	20	15	12	10	9	8	7	6	6	5	5	4	4	4	4	3	3	3

Estimating Guide for 30 oz. Cartridge and Steel Screen Tubes – Installations per Cartridge

Rod Dia. (in.)	Drill Bit Dia. (in.)	THREADED ROD INSERTED IN SCREEN TUBE HOLE DEPTH (inches)																		
		3 1/2	4	4 1/2	5	5 1/2	6	6 1/2	7	7 1/2	8	9	10	11	12	13	14	15	16	17
3/8	9/16	67	59	52	47	43	39	36	33	31	29	26	23							
1/2	1 1/16	42	37	33	30	27	25	23	21	20	19	16	15							
5/8	7/8	24	21	19	17	15	14	13	12	11	10	9	8	8	7	6				
3/4	1	18	16	14	12	11	10	10	9	8	8	7	6	6	5	5	4	4	4	4

Estimating Guide for 30 oz. Cartridge and Plastic Screen Tubes – Installations per Cartridge

Rod Dia. (in.)	Drill Bit Dia. (in.)	THREADED ROD INSERTED IN SCREEN TUBE HOLE DEPTH (inches)																						
		3 1/2	4	4 1/2	5	5 1/2	6	6 1/2	7	7 1/2	8	9	10	11	12	13	14	15	16	17	18	19	20	21
3/8	9/16	78	69	61	55	50	46	42	39	37	34	31	27											
1/2	1 1/16	41	36	32	28	26	24	22	20	19	18	16	14											
5/8	7/8	28	24	22	19	18	16	15	14	13	12	11	10	9	8	7								
3/4	1	20	18	16	14	13	12	11	10	9	9	8	7	6	6	5	5	4	4	4	4	4	4	3

Tables are estimations. Actual usage may vary depending on waste.
Note: Online adhesive cartridge quantity estimating tools are available by visiting www.strongtie.com

Adhesive Anchoring Installation Instructions

Anchoring Adhesives



NOTE: Always check expiration date on product label. Do not use expired product.



WARNING: When drilling and cleaning hole, use eye and lung protection. When installing adhesive, use eye and skin protection.

1 HOLE PREPARATION: Horizontal, Vertical and Overhead Applications

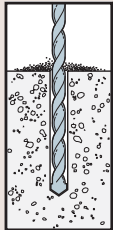

1. Drill—Drill hole to specified diameter and depth.

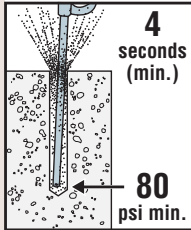

2. Blow—Remove dust from hole with oil-free compressed air for a minimum of 4 seconds. Compressed air nozzle **must** reach the bottom of the hole.

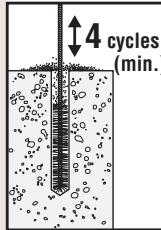

3. Brush—Clean with a nylon brush for a minimum of 4 cycles. Brush should provide resistance to insertion. If no resistance is felt, the brush is worn and must be replaced.

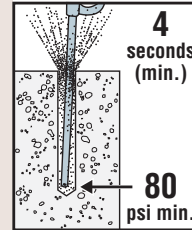

4. Blow—Remove dust from hole with oil-free compressed air for a minimum of 4 seconds. Compressed air nozzle **must** reach the bottom of the hole.

Refer to page 77 or visit www.strongtie.com for proper brush part number.

2 CARTRIDGE PREPARATION:

1. Check—Check expiration date on product label. Do not use expired product. Product is usable until end of printed expiration month.

2. Open—Open cartridge per package instructions.

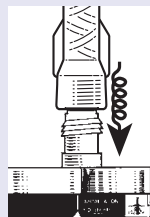

Refer to www.strongtie.com for proper mixing nozzle and dispensing tool part number.

3. Attach—Attach proper Simpson Strong-Tie® nozzle and extension to cartridge. Do not modify nozzle.



4. Insert—Insert cartridge into dispensing tool.

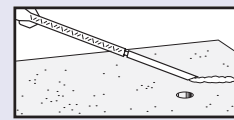

5. Dispense—Dispense adhesive to the side until properly mixed (uniform color).

3 FILLING THE HOLE: Vertical Anchorage

Prepare the hole per instructions “Hole Preparation” on product label.

Dry and Damp Holes:

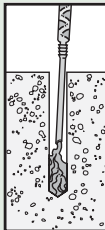

1. Fill—Fill hole $\frac{1}{2}$ – $\frac{2}{3}$ full, starting from bottom of hole to prevent air pockets. Withdraw nozzle as hole fills up.

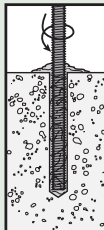

Threaded rod or rebar

2. Insert—Insert clean, oil free anchor, turning slowly until the anchor contacts the bottom of the hole.

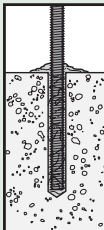

3. Do not disturb—Do not disturb anchor until fully cured. (See cure schedule for specific adhesive.)

Water-Filled Holes:

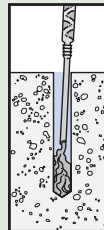

1. Fill—Fill hole completely full, starting from bottom of hole to prevent water pockets. Withdraw nozzle as hole fills up.

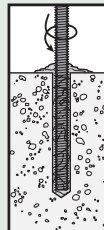

Threaded rod or rebar

2. Insert—Insert clean, oil-free anchor, turning slowly until the anchor contacts the bottom of the hole.

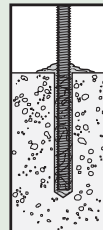

3. Do not disturb—Do not disturb anchor until fully cured. (See cure schedule.)

Note: Nozzle extensions may be needed for deep holes.

FILLING THE HOLE: Horizontal and Overhead Anchorage

Prepare the hole per instructions “Hole Preparation” on product label.

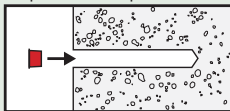

1. Install—Install Simpson Strong-Tie® ARC adhesive retaining cap. Refer to page 74 or visit www.strongtie.com for proper ARC size.

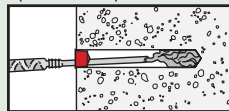

2. Fill—Fill hole $\frac{1}{2}$ – $\frac{2}{3}$ full, starting from bottom of hole to prevent air pockets. Withdraw nozzle as hole fills up.

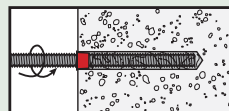

3. Insert—Insert clean, oil-free anchor, turning slowly until the anchor contacts the bottom of the hole.

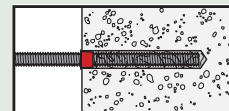

4. Do not disturb—Do not disturb anchor until fully cured (see cure schedule).

Note: Nozzle extensions may be needed for deep holes.

Adhesive Anchoring Installation Instructions

Continued from page 70.

FILLING THE HOLE: When Anchoring with Screens: For AT, ET-HP, and SET Adhesives (except SET1.7KTA)

Prepare the hole per instructions "Hole Preparation".

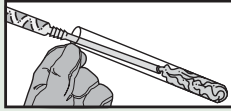

1. Fill—Fill screen completely. Fill from the bottom of the screen and withdraw the nozzle as the screen fills to prevent air pockets. (Opti-Mesh® screens: Close integral cap after filling.)



2. Insert—Insert adhesive filled screen into hole.

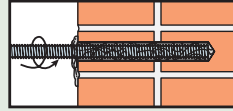

3. Insert—Insert clean, oil-free anchor, turning slowly until the anchor contacts the bottom of the screen.

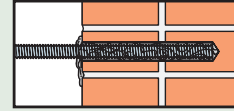

4. Do not disturb—Do not disturb anchor until fully cured. (See cure schedule for specific adhesive.)

FILLING THE HOLE: VGC Vinylester Glass Capsule (Hammer Capsule)

Prepare the hole per instructions "Hole Preparation".

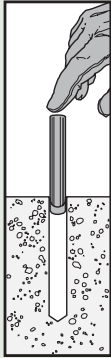

1. Insert—Insert the VGC capsule(s) to the bottom of the hole (either end first).

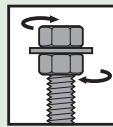

2. Install—Install double nut to protect thread.

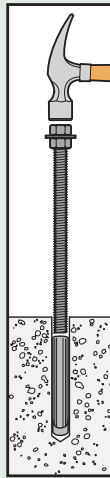

3. Drive—Drive stud or rod to the bottom of the hole. Spinning of the stud or rod is not required.

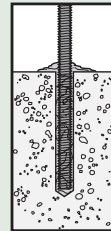

4. Do not disturb—Do not disturb anchor until fully cured. (See cure schedule for VGC.) **VGC is not recommended for overhead applications.**

Adhesive Accessories

Adhesive Dispensing Tools

Our heavy-duty tools are designed to work with our cartridges for trouble-free dispensing. Each manual tool provides a 26:1 drive mechanism for easier dispensing of high-viscosity adhesive.

Epoxy Adhesive Dispensing Tools

NEW

CDT10S

Manual Dispensing Tool for SET-XP®10 Adhesive and other Single Cartridge Adhesives

The CDT10S features a steel carriage for ultimate durability and is engineered for continuous, high-volume use. The CDT10S also features double-gripping plates that help extend tool life.



CDT10S

NEW

EDT22S

Manual Dispensing Tool for 22 oz. Adhesive Cartridges

The EDT22S epoxy adhesive tool features a steel carriage and is engineered for high-volume, continuous use. The tool can be easily convert from dispensing a 22 oz. 1:1 ratio cartridge to a 16.5 oz. 2:1 ratio cartridge.



EDT22S

EDT22CKT

Battery-Powered Dispensing Tool for 22 oz. Cartridges

The EDT22CKT offers power dispensing without the need for a hose or compressor. The tool features dosage and rate control for maximum efficiency. Each battery charge dispenses approximately 25 cartridges and recharging takes 1 hour. Tool comes complete with two 14.4V batteries and a charger.



EDT22CKT Tool and Charger

NEW

EDTA22P

Pneumatic Dispensing Tool for 22 oz. Cartridges

The EDTA22P tool features an optional suitcase handle adapter for the ultimate in tool configuration and dispensing convenience. The suitcase option enables easier and time-saving ground-level doweling. The heavy-duty tool comes with a custom, blow-molded plastic carrying case.



EDTA22P

NEW

EDTA56P

Pneumatic Dispensing Tool for 56 oz. Cartridges

The EDTA56P tool features an optional suitcase handle adapter for the ultimate in tool configuration and dispensing convenience. The suitcase option enables easier and time-saving ground-level doweling. The heavy-duty tool comes with a custom, blow-molded plastic carrying case.



EDTA56P

Description	Model No.
Premium tool for single-tube cartridges	CDT10S
Manual tool for 22 oz. cartridges	EDT22S
Battery-powered tool for 22 oz. cartridges	EDT22CKT
Pneumatic tool for 22 oz. cartridges ^{1, 2}	EDTA22P
Pneumatic tool for 56 oz. cartridges ^{1, 2}	EDTA56P

1. Air supply attachment is 1/4-18 NPT (male) thread.
2. Recommended operating air pressure is between 80-100 psi.

Maintenance tips, troubleshooting and repair parts schematics available at www.strongtie.com.

Adhesive Accessories

Adhesive Accessories

Acrylic Adhesive Dispensing Tools

NEW **ADT813S**

Manual Dispensing Tool for 12.5 oz. Cartridges

The ADT813S features a steel carriage for ultimate durability. The ADT813S also features double-gripping plates that help extend tool life.



ADT813S

NEW **ADT30S**

Manual Dispensing Tool for 30 oz. Adhesive Cartridges

The ADT30S features a steel carriage for ultimate durability and is engineered for continuous, high-volume use. The ADT30S also features double-gripping plates that help extend tool life.



ADT30S

ADT30CKT

Battery Powered Dispensing Tool for 30 oz. Cartridges

The ADT30CKT offers power dispensing without the need for a hose or compressor. The tool features dosage and rate control for maximum efficiency. Each battery charge dispenses approximately 25 cartridges and recharging takes 1 hour. The tool comes complete with two 14.4V batteries and a charger.



ADT30CKT

EDT14VCH

NEW **ADTA30P**

Pneumatic Dispensing Tool for 30 oz. Cartridges

The ADTA30P tool features an optional suitcase handle adapter for flexible tool configuration and dispensing convenience. The suitcase option enables easier and time-saving ground-level doweling. The heavy-duty tool comes with a custom, blow-molded plastic carrying case.



ADTA30P

Description	Model No.
Manual tool for 12.5 oz. cartridges	ADT813S
Manual tool for 30 oz. cartridges	ADT30S
Battery-powered tool for 30 oz. cartridges	ADT30CKT
Pneumatic tool for 30 oz. cartridges ^{1, 2}	ADTA30P
ADT30CKT battery	EDT14B
ADT30CKT charger	EDT14VCH

1. Air supply attachment is 1/4-18 NPT (male) thread.
2. Recommended operating air pressure is between 80–120 psi.

C-SAS-2012 © 2012 Simpson Strong-Tie Company Inc.

Maintenance tips, troubleshooting and repair parts schematics available at www.strongtie.com.

Adhesive Accessories

Adhesive Accessories

Mixing Nozzles and Retaining Nuts

Mixing nozzles are designed for the proper proportioning and mixing of the different adhesive formulations. Use only appropriate Simpson Strong-Tie mixing nozzle in accordance with Simpson Strong-Tie instructions. Modification or improper use of the mixing nozzle may impair epoxy or acrylic performance.

EMN22i – An 18-element mixing nozzle for use with 22 oz. and 56 oz. epoxy adhesives cartridges. This is a one-piece nozzle with integrated nut (separate retaining nut not required).

AMN19Q – An 19-element, high-efficiency static mixing nozzle for use with all acrylic adhesive products.

EMN37A – An 18-element, high-strength, mixing nozzle for dispensing epoxy adhesive through bulk metering equipment.



EMN22i



EMN37A



AMN19Q

Description	Model No.	Pkg Qty	Ctn Qty
Mixing nozzle for 1.7 oz. cartridge (separate retaining nut not required).	EMN1.7-R	2	24 Packs (2 nozzles per pack)
18-element nozzle for 22 oz. and epoxy adhesive. Features an integrated threaded nut for attachment to cartridges.	EMN22i	1	12 Nozzles
	EMN22i-RP5	5	6 Packs (5 nozzles per pack)
	EMN22i-RP10	10	3 Packs (10 nozzles per pack)
	EMN22iB	—	500
18-element nozzle for dispensing epoxy through metering equipment	EMN37A-RP5	5	6 Packs (5 nozzles per pack)
Hi-volume nozzle for 22 oz., and 56 oz. cartridges (separate retaining nut not required), 17" long, major diameter 7/8"	EMN50	—	10
Five mixing nozzles for all AT products	AMN19Q-RP5	5	10 Packs (5 nozzles per pack)

Adhesive Retaining Caps

Adhesive retaining caps make overhead and horizontal installation easier by preventing the adhesive from running out of the hole. They also center the rod in the hole, making them ideal for applications where precise anchor placement is required. It may be necessary to provide support for the insert during cure time. Adhesive retaining caps are not designed to support the weight of the insert in overhead installations.

MATERIAL: Plastic



Adhesive Retaining Caps

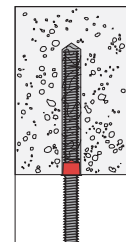
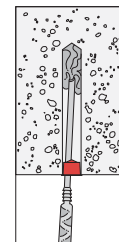

The "X" cut in the cap allows the mixing nozzle and insert to pass through, while containing the adhesive in the hole.

Epoxy Adhesive Retaining Caps

Model No.	For Rod Dia. (in)	Required Hole Diameter (in)	Cap Depth (in)	Pkg Qty	Ctn Qty* (ea)
ARC37-RP25	3/8	1/2	7/16	25	200
ARC50-RP25	1/2	5/8	1/2	25	200
ARC62-RP25	5/8	3/4	9/16	25	200
ARC75-RP25	3/4	7/8	9/16	25	200
ARC87-RP25	7/8	1	11/16	25	200
ARC100-RP25	1	1 1/8	11/16	25	200
ARC125-RP25	1 1/4	1 3/8	7/8	25	200

Acrylic Adhesive Retaining Caps

Model No.	For Rod Dia. (in)	Required Hole Diameter (in)	Cap Depth (in)	Pkg Qty	Ctn Qty* (ea)
ARC37A-RP25	3/8	7/16	7/16	25	200
ARC50A-RP25	1/2	9/16	1/2	25	200
ARC62A-RP25	5/8	11/16	9/16	25	200
ARC75A-RP25	3/4	13/16	9/16	25	200
ARC87-RP25	7/8	1	11/16	25	200
ARC100A-RP25	1	1 1/16	11/16	25	200
ARC125-RP25	1 1/4	1 3/8	7/8	25	200

*8 packages of 25.

Adhesive Accessories

Steel Adhesive-Anchoring Screen Tubes

Screen tubes are used in hollow base material applications to contain adhesive around the anchor and prevent it from running into voids. Simpson Strong-Tie® screen tubes are specifically designed to work with AT, SET and ET-HP adhesives in order to precisely control the amount of adhesive that passes through the mesh. This results in thorough coating and bonding of the rod to the screen tube and base material. Order screen tubes based upon rod diameter and adhesive type. The actual outside diameter of the screen tube is larger than the rod diameter.

MATERIAL: Acrylic screen tubes: 50 mesh stainless steel;
Epoxy screen tubes: 60 mesh carbon steel.



Caution: Screen tubes are designed for a specific adhesive type. epoxy screen tubes must be used with SET or ET-HP formulations and acrylic screen tubes must be used with AT adhesive. Do not use SET1.7KTA with screen tubes.



Epoxy Adhesive Screen Tube
(Acrylic Screen Tubes Similar)

Screen tubes are for use in hollow CMU, hollow brick and unreinforced masonry applications.

Contact Simpson Strong-Tie for information on special order sizes.

Adhesive Accessories

Acrylic (AT) Screen Tubes – Stainless Steel

For Rod Dia. (in.)	Hole Size (in.)	Actual Screen Size O.D./Length (in.)	Model No.	Carton Qty.
3/8	9/16	15/32 x 3 1/2	ATS373	150
		15/32 x 6	ATS376	150
1/2	11/16	19/32 x 3 1/2	ATS503	100
		19/32 x 6	ATS506	100
		19/32 x 10	ATS5010	50
5/8	7/8	25/32 x 3	ATS623	50
		25/32 x 6	ATS626	50
		25/32 x 10	ATS6210	25
		25/32 x 13	ATS6213	25
3/4	1	29/32 x 8	ATS758	25
		29/32 x 13	ATS7513	25
		29/32 x 17	ATS7517	25

Epoxy (SET & ET-HP) Screen Tubes – Carbon Steel

For Rod Dia. (in.)	Hole Size (in.)	Actual Screen Size O.D./Length (in.)	Model No.	Carton Qty.
3/8	9/16	15/32 x 6	ETS376	150
		15/32 x 10	ETS3710	100
1/2	11/16	19/32 x 6	ETS506	100
		19/32 x 10	ETS5010	50
5/8	7/8	25/32 x 6	ETS626	50
		25/32 x 10	ETS6210	25
		25/32 x 13	ETS6213	25
3/4	1	29/32 x 8	ETS758	25
		29/32 x 13	ETS7513	25
		29/32 x 17	ETS7517	25
		29/32 x 21	ETS7521	25

Note: Not for use with SET1.7KTA.

Adhesive Accessories

Opti-Mesh® Adhesive-Anchoring Screen Tubes

Screen tubes are vital to the performance of adhesive anchors in base materials that are hollow or contain voids, such as hollow block and brick. The Simpson Strong-Tie® Opti-Mesh® screen tube provides the economical advantage of a plastic screen tube while providing performance comparable to steel screen tubes and better than competitive plastic screen tubes.

MATERIAL: Plastic

Caution: Screen tubes are designed for a specific adhesive type. Epoxy screen tubes must be used with SET or ET-HP formulations and acrylic screen tubes must be used with AT adhesive. Do not use SET1.7KTA with screen tubes.

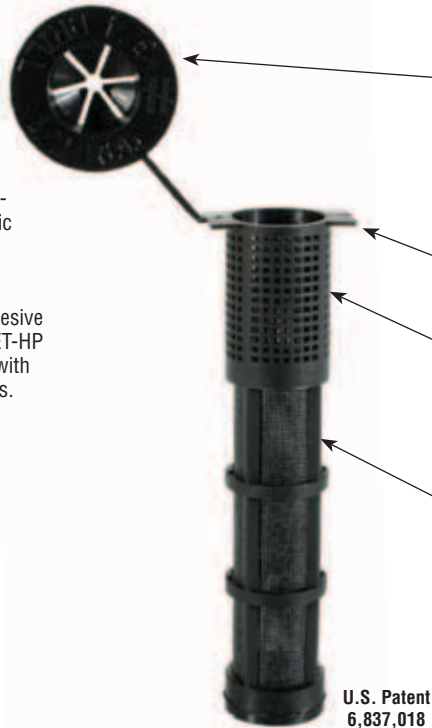

Integral Cap: Serves to center and secure the rod in the screen tube, while displaying important information such as rod diameter, drill bit diameter and the Simpson Strong-Tie® "S" sign for easy inspection after installation. The cap also prevents adhesive from running out of the front of the screen tube.

Flanges: Prevents the screen tube from slipping into over-drilled holes. Allows screen tube to function in holes that are drilled too deep.

Open-Mesh Collar: This section of larger mesh allows extra adhesive to flow out of the screen tube behind the face shell of hollow block applications. The extra "collar" of adhesive increases bearing area and results in higher load capacities in hollow concrete block.

Color-Coded, Formula-Specific Mesh: The screen tube mesh is sized to allow only the right amount of adhesive to flow through the screen tube to bond with the base material while the balance remains in the screen to bond the rod. The acrylic screen tube mesh is white while the epoxy screen tube mesh is black.

U.S. Patent
6,837,018

Epoxy Screen Tube
(mesh is black)



The integral cap centers the rod and displays drill bit and rod diameter.

Acrylic Screen Tube
(mesh is white)

Epoxy (SET and ET-HP) Screen Tubes - Plastic

For Rod Dia. (in)	Hole Size (in)	Length (in)	Model No.	Carton Qty.
3/8	9/16	3 1/2	ETS373P	150
		6	ETS376P	150
		10	ETS3710P	100
1/2	3/4	3 1/2	ETS503P	100
		6	ETS506P	100
		10	ETS5010P	50
5/8	7/8	3 1/2	ETS623P	50
		6	ETS626P	50
		10	ETS6210P	25
3/4	1	13	ETS6213P	25
		8	ETS758P	25
		13	ETS7513P	25
3/4	1	17	ETS7517P	25
		21	ETS7521P	25

Load values for installations with SET are on page 30. Load values for installations with ET-HP in unreinforced masonry are on page 44. Not for use with SET1.7KTA.

Acrylic Screen Tubes - Plastic

For Rod Dia. (in)	Hole Size (in)	Length (in)	Model No.	Carton Qty.
3/8	9/16	3 1/2	ATS373P	150
		6	ATS376P	150
		10	ATS3710P	100
1/2	3/4	3 1/2	ATS503P	100
		6	ATS506P	100
		10	ATS5010P	50
5/8	7/8	3 1/2	ATS623P	50
		6	ATS626P	50
		10	ATS6210P	25
3/4	1	13	ATS6213P	25
		8	ATS758P	25
		13	ATS7513P	25
3/4	1	17	ATS7517P	25
		21	ATS7521P	25

Load values for installations with AT adhesive are on page 61.

Screen tubes are for use in hollow CMU, hollow brick and unreinforced masonry applications.



The photo on the left shows the Opti-Mesh® screen tube installed in a hollow CMU block. The extra collar of adhesive created by the open-mesh collar results in increased bearing area and higher load values. The typical screen tube shown on the right relies on the bond between the relatively small amount of adhesive in contact with the face shell of the block for its holding power.

Adhesive Accessories

Adhesive Accessories

Hole Cleaning Brushes

Brushes are used for cleaning drilled holes prior to adhesive anchor installation. Brushes have a twisted wire handle with nylon bristles.

Description	Model No.	For Anchor/Rebar Diameter (in.)	For Hole Diameter (in.)	Ctn Qty
½" dia x 3" brush (8" total length)	ETB4	¼" – ⅝"	⅜" – 7⁄16"	24
¾" x 4" brush (16" total length)	ETB6	⅜" – ⅝"	½" – ¾"	24
1" x 4" brush (16" total length)	ETB8	¾"	1⅜" – 7⁄8"	24
1" x 4" brush (24" total length)	ETB8L	¾"	1⅜" – 7⁄8"	24
1¼" x 4" brush (29" total length)	ETB10	7⁄8" – 1"	1" – 1 1⁄8"	24
1 5⁄8" x 6" brush (34" total length)	ETB12	1 ¼"	1 3⁄16" – 1 3⁄8"	24

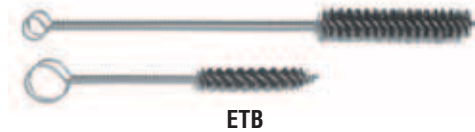

ETB

Adhesive Shear Tubes

Used in conjunction with anchoring adhesive and screen tubes, adhesive shear tubes transfer anchor shear loads over a larger area, reducing localized crushing in unreinforced masonry installations. Required for thru bolt applications per ICC-ES's unreinforced masonry anchorage "Configuration C" detail. For detailed installation instructions refer to the appropriate adhesive anchor ICC-ES report.

MATERIAL: Steel

FINISH: Zinc-plated

Description (in.)	Model No.	For use with Simpson Screen Model No. ¹	Drill Bit Dia. (in.)	Threaded Rod Diameter (in.)	Carton Qty.
1⅜ x 8	AST800	ETS758, ATS758	1	5⁄8	1

1. Screens sold separately. Not for use with Simpson Strong-Tie screen #ETS758P or ATS758P plastic Opti-Mesh screen tubes.



Adhesive Shear Tube

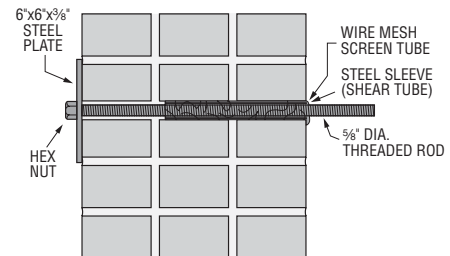

Configuration C

Retrofit Bolts

RFBs are pre-cut threaded rod, supplied with nut and washer. For use with Simpson Strong-Tie® adhesives. May be ordered in bulk without the nut and washer. Use with Simpson Strong-Tie adhesives to anchor into existing concrete and masonry. Offers a complete engineered anchoring system when used with Simpson Strong-Tie anchoring adhesives. Each end of the threaded rod is stamped with rod length in inches and our "No-Equal" symbol for easy identification after installation.

MATERIAL: ASTM F1554 Grade 36

FINISH: Zinc-plated, hot-dip galvanized

Description Dia. Length	Zinc Plated Model No.	Hot-Dip Galvanized Model No.	Ctn Qty	Bulk ¹ Qty	Retail ² Pack
½" x 4"	RFB#4x4	RFB#4x4HDG	50	50	–
½" x 5"	RFB#4x5	RFB#4x5HDG	50	50	10
½" x 6"	RFB#4x6	RFB#4x6HDG	50	50	10
½" x 7"	RFB#4x7	RFB#4x7HDG	50	50	10
½" x 8"	–	RFB#4x8HDG	–	–	10
½" x 10"	RFB#4x10	RFB#4x10HDG	25	–	10
5⁄8" x 5"	RFB#5x5	RFB#5x5HDG	50	50	10
5⁄8" x 8"	RFB#5x8	RFB#5x8HDG	50	–	10
5⁄8" x 10"	RFB#5x10	RFB#5x10HDG	50	–	10
5⁄8" x 12"	–	RFB#5x12HDG	–	–	10
5⁄8" x 16"	RFB#5x16	RFB#5x16HDG	25	25	10
¾" x 10 ½"	RFB#6x10.5	RFB#6x10.5HDG	25	25	–



RFB Retrofit Bolts

1. Bulk quantities do not include the nut and washer and must be ordered with a "-B" suffix (example: RFB#4x5-B). Hot-dip galvanized RFB's not available in bulk.
2. Retail packs must be ordered with a "-R" suffix (example: RFB#5x12HDG-R).

Adhesive Troubleshooting Guide

PROBLEM	CAUSE	SOLUTION
1) Material not flowing through nozzle.	Gelled or hardened adhesive in nozzle. Adhesive can harden in the nozzle at 70°F in about 5–7 minutes. As the air temperature increases, gel time is shorter.	Replace mixing nozzle.
	Too cold for adhesive to flow.	Keep Material in heated storage area: Store epoxy at 45°–90°F; Store Acrylic at 32°–80°F.
	Surface is crusting.	Remove nozzle, dispense small amount of material, then replace nozzle.
	Obstruction in nozzle or on outlet of cartridge.	Change to new nozzle or remove obstruction from cartridge outlet.
	Insufficient air pressure to the pneumatic tool.	Set air pressure at 80 - 100 psi.
2) Leakage from front of threaded section of cartridge.	Nozzle coupling nut is cross-threaded.	Remove coupling nut and reattach, taking care not to cross-thread.
	Cracked or punctured cartridge.	Do not attempt to dispense damaged cartridge.
3) Material leaking from back of cartridge during dispensing.	Excessive pressure resulting in swelling of cartridge or misalignment of retaining wiper.	Regulate air pressure on pneumatic tool.
		Do not overdrive manual tool.
		See problem 1 to find out why material is not flowing.
	Misalignment of tool push rods and cartridge.	Adjust/repair dispensing tool.
	Misalignment of cartridge.	Make sure cartridge is inserted correctly.
4) Resin (white) getting into hardener (black) chamber or vice versa.	Excessive pressure.	Regulate air pressure on pneumatic tool.
		Do not overdrive manual tool.
		Check to see mixing nozzle is not filled with gelled or hardened epoxy.
		Make sure one of the cartridges is not leaking out of the bottom (refer to problem 3).
5) Hardener (black) only being dispensed or mixture is too dark.	Adhesive too cold to flow and mix properly.	Keep material in heated storage area: Store epoxy at 45°– 90°F; Store acrylic at 32°– 80°F.
6) Adhesive won't harden in hole.	Adhesive not mixed thoroughly.	Abandon hole and drill new hole. If not possible, call Simpson Strong-Tie.
		Make sure wipers on cartridge are equalized prior to dispensing and adhesive being dispensed is a uniform color before filling holes. Attach nozzle and dispense adhesive to the side until properly mixed (uniform color).
	Base material too cold for epoxy being used.	Allow more time for epoxy to cure.
		Use AT acrylic adhesive when base material temperature is below 40°F.

VGC Vinylester Glass Capsule Anchoring Adhesive

The VGC system is a two-component, high solids, vinylester-based adhesive contained within a glass capsule. The capsule is placed in the hole and the resin and initiator components are combined when the rod or rebar is driven to the bottom of the hole through the capsule.

- USES:**
- Anchoring threaded rod or rebar in solid base materials
 - Not for overhead installations

SPECIAL FEATURES:

- Fast cure
- No special tools required for use
- Hammer-in or spin-in (if desired)
- Pre-measured amounts for listed embedment and load - no waste
- Capsules are bi-directional — either end can be inserted into the hole first

APPLICATION: Holes to receive adhesive must be clean and free of concrete dust and/or dirt, oil or grease. For dependable results, adhesive should be applied in dry conditions. Do not install in or through standing water. The base material must be 25°F (-4°C) or above at the time of installation. ALWAYS WEAR EYE PROTECTION!

INSTALLATION: See pages 70–71

SHELF LIFE: 12 months from date of manufacture in original packaging.

STORAGE CONDITIONS: For maximum shelf life, keep cool (60°F - 90°F) and in closed packaging. Exposing capsules to UV light sources will shorten shelf life. Capsules are fragile. Do not use capsules if they change color, become cloudy or are cracked.

CLEAN UP: If broken – Allow material to cure
Cured material – Chip or grind off surface

TEST CRITERIA: Anchors installed with the VGC adhesive have been tested in accordance with ICC-ES's *Acceptance Criteria for Adhesive Anchors (AC58)*.

SUGGESTED SPECIFICATION: Anchoring adhesive shall be a two-component vinylester based adhesive capsule-within-a-capsule system supplied in manufacturer's standard packaging. Adhesive shall be the VGC adhesive system from Simpson Strong-Tie Company Inc., Pleasanton, CA. Anchors shall be installed per Simpson Strong-Tie instructions for the VGC adhesive system.



VGC50

VGC Product Data

Rod Dia. or Rebar Size	VGC Capsule	Act. Capsule Size in. (mm)	Package Quantity
3/8" or #3	VGC37	7/16 x 3 1/2 (11.1 x 88.9)	10
1/2" or #4	VGC50	1/2 x 3 7/8 (12.7 x 98.4)	10
5/8" or #5	VGC62	5/8 x 3 7/8 (15.9 x 98.4)	10
3/4" or #6	VGC75	5/8 x 7 (15.9 x 177.8)	5
7/8" or #7 1" or #8	VGC100	7/8 x 8 (22.2 x 203.2)	5

Cure Schedule

Base Material Temperature		Cure Time
°F	°C	
25	-4	5 hrs.
32	0	1 hr.
50	10	30 min.
68	20	20 min.

IMPORTANT – See Pages 71 for Installation Instructions

Vinylester Adhesive

C-SAS-2012 © 2012 Simpson Strong-Tie Company Inc.

Tension Loads for Threaded Rod Anchors in Normal-Weight Concrete – One (1) VGC Capsule Per Hole



Rod Dia. in. (mm)	VGC Capsule	Drill Bit Dia. in.	Embed. Depth in. (mm)	Critical Edge Dist. in. (mm)	Critical Spacing Dist. in. (mm)	Tension Load Based on Bond Strength						Tension Load Based on Steel Strength
						f'c ≥ 2000 psi (13.8 MPa) Concrete			f'c ≥ 4000 psi (27.6 MPa) Concrete			F1554 Grade 36
						Ultimate lbs. (kN)	Std. Dev. lbs. (kN)	Allowable lbs. (kN)	Ultimate lbs. (kN)	Std. Dev. lbs. (kN)	Allowable lbs. (kN)	Allowable lbs. (kN)
3/8 (9.5)	VGC37	7/16	3 1/2 (88.9)	5 1/4 (133)	14 (356)	5,585 (24.8)	504 (2.2)	1,395 (6.2)	6,875 (30.6)	692 (3.1)	1,720 (7.7)	2,105 (9.4)
1/2 (12.7)	VGC50	9/16	4 1/4 (108)	6 3/8 (162)	17 (432)	9,653 (42.9)	546 (2.4)	2,410 (10.7)	10,800 (48.0)	1,494 (6.6)	2,700 (12.0)	3,750 (16.7)
5/8 (15.9)	VGC62	1 1/16	5 (127)	7 1/2 (191)	20 (508)	•	•	4,265 (19.0)	17,048 (75.8)	1,345 (6.0)	4,265 (19.0)	5,875 (26.1)
3/4 (19.1)	VGC75	7/8	7 (178)	10 1/2 (267)	28 (711)	21,605 (96.1)	2,643 (11.8)	5,400 (24.0)	26,598 (118.3)	2,087 (9.3)	6,650 (29.6)	8,460 (37.6)
7/8 (22.2)	VGC100	1	8 (203)	11 3/8 (295)	32 (813)	•	•	7,310 (32.5)	30,837 (137.2)	1,174 (5.2)	7,709 (34.3)	11,500 (51.2)
1 (25.4)	VGC100	1 1/8	8 (203)	13 1/2 (343)	32 (813)	29,236 (130.0)	3,263 (14.5)	7,310 (32.5)	38,205 (169.9)	3,166 (14.1)	9,550 (42.5)	15,025 (66.8)

1. Allowable load must be the lesser of the bond or steel strength.
2. The allowable loads listed under allowable bond are based on a safety factor of 4.0.
3. Allowable loads may not be increased for short-term loading due to wind or seismic forces.
4. Refer to allowable load-adjustment factors for spacing and edge distance on pages 82–83.
5. Anchors are permitted to be used within fire-resistive construction, provided the anchors resist wind or seismic loads only. For use in fire-resistive construction, the anchors can also be permitted to be used to resist gravity loads, provided special consideration has been given to fire-exposure conditions.
6. Anchors are not permitted to resist tension forces in overhead or wall installations unless proper consideration is given to fire-exposure conditions.

*See page 13 for an explanation of the load table icons

VGC Vinyl Ester Glass Capsule Anchoring Adhesive

Vinylester Adhesive

**Shear Loads for Threaded Rod Anchors
in Normal-Weight Concrete – One (1) VGC Capsule Per Hole**

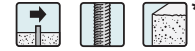

Rod Dia. in. (mm)	VGC Capsule	Drill Bit Dia. in.	Embed. Depth in. (mm)	Critical Edge Dist. in. (mm)	Critical Spacing Dist. in. (mm)	Shear Load Based on Concrete Edge Distance			Shear Load Based on Steel Strength		
						$f'_c \geq 2000$ psi (13.8 MPa) Concrete			F1554 Grade 36	A193 GR B7	F593 304SS
						Ultimate lbs. (kN)	Std. Dev. lbs. (kN)	Allowable lbs. (kN)	Allowable lbs. (kN)	Allowable lbs. (kN)	Allowable lbs. (kN)
3/8 (9.5)	VGC37	7/16	3 1/2 (88.9)	5 1/4 (133)	5 1/4 (133)	5,581 (24.8)	311 (1.4)	1,395 (6.2)	1,085 (4.8)	2,340 (10.4)	1,870 (8.3)
1/2 (12.7)	VGC50	9/16	4 1/4 (108)	6 3/8 (162)	6 3/8 (162)	12,877 (57.3)	398 (1.8)	3,220 (14.3)	1,930 (8.6)	4,160 (18.5)	3,330 (14.8)
5/8 (15.9)	VGC62	1 1/16	5 (127)	7 1/2 (191)	7 1/2 (191)	18,702 (83.2)	675 (3.0)	4,675 (20.8)	3,025 (13.5)	6,520 (29.0)	5,220 (23.2)
3/4 (19.1)	VGC75	7/8	7 (178)	10 1/2 (267)	10 1/2 (267)	29,537 (131.4)	1,102 (4.9)	7,385 (32.9)	4,360 (19.4)	9,390 (41.8)	6,385 (28.4)
7/8 (22.2)	VGC100	1	8 (203)	11 5/8 (295)	11 5/8 (295)	33,676 (149.8)	1,274 (5.7)	8,420 (37.5)	5,925 (26.4)	12,770 (56.8)	8,685 (38.6)
1 (25.4)	VGC100	1 1/8	8 (203)	13 1/2 (343)	13 1/2 (343)	44,486 (197.9)	4,143 (18.4)	11,120 (49.5)	7,740 (34.4)	16,680 (74.2)	11,345 (50.5)

*See page 13 for an explanation of the load table icons

1. Allowable load must be the lesser of the load based on concrete edge distance or steel strength.
2. The allowable loads based on concrete edge distance are based on a safety factor of 4.0.
3. Allowable loads may not be increased for short-term loading due to wind or seismic forces.
4. Refer to allowable load-adjustment factors for spacing and edge distance on pages 82–83.
5. Anchors are permitted to be used within fire-resistive construction, provided the anchors resist wind or seismic loads only. For use in fire-resistive construction, the anchors can also be permitted to be used to resist gravity loads, provided special consideration has been given to fire-exposure conditions.

**Tension Loads for Threaded Rod Anchors
in Normal-Weight Concrete – Two (2) VGC Capsules Per Hole**



Rod Dia. in. (mm)	VGC Capsule Two (2) Per Hole	Drill Bit Dia. in.	Embed. Depth in. (mm)	Critical Edge Dist. in. (mm)	Critical Spacing Dist. in. (mm)	Tension Load Based on Bond Strength			Tension Load Based on Steel Strength		
						$f'_c \geq 2000$ psi (13.8 MPa) Concrete			F1554 Grade 36	A193 GR B7	F593 304SS
						Ultimate lbs. (kN)	Std. Dev. lbs. (kN)	Allowable lbs. (kN)	Allowable lbs. (kN)	Allowable lbs. (kN)	Allowable lbs. (kN)
3/8 (9.5)	VGC37	7/16	7 (178)	10 1/2 (267)	28 (711)	10,298 (45.8)	333 (1.5)	2,575 (11.5)	2,105 (9.4)	4,535 (20.2)	3,630 (16.1)
1/2 (12.7)	VGC50	9/16	8 1/2 (216)	12 3/4 (324)	34 (864)	18,530 (82.4)	134 (0.6)	4,635 (20.6)	3,750 (16.7)	8,080 (35.9)	6,470 (28.8)
5/8 (15.9)	VGC62	1 1/16	10 (254)	15 (381)	40 (1016)	26,931 (119.8)	1,696 (7.5)	6,735 (30.0)	5,875 (26.1)	12,660 (56.3)	10,120 (45.0)
3/4 (19.1)	VGC75	7/8	14 (356)	21 (533)	56 (1422)	47,469 (211.2)	1,731 (7.7)	11,865 (52.8)	8,460 (37.6)	18,230 (81.1)	12,400 (55.2)
7/8 (22.2)	VGC100	1	16 (406)	24 (610)	64 (1626)	50,728 (225.6)	1,565 (7.0)	12,680 (56.4)	11,500 (51.2)	24,785 (110.2)	16,860 (75.0)
1 (25.4)	VGC100	1 1/8	16 (406)	24 (610)	64 (1626)	72,128 (320.8)	3,089 (13.7)	18,030 (80.2)	15,025 (66.8)	32,380 (144.0)	22,020 (97.9)

*See page 13 for an explanation of the load table icons

1. Allowable load must be the lesser of the bond or steel strength.
2. The allowable loads listed under allowable bond are based on a safety factor of 4.0.
3. Allowable loads may not be increased for short-term loading due to wind or seismic forces.
4. Refer to allowable load-adjustment factors for spacing and edge distance on pages 82–83.
5. Anchors are permitted to be used within fire-resistive construction, provided the anchors resist wind or seismic loads only. For use in fire-resistive construction, the anchors can also be permitted to be used to resist gravity loads, provided special consideration has been given to fire-exposure conditions.
6. Anchors are not permitted to resist tension forces in wall installations unless proper consideration is given to fire-exposure conditions.

VGC Vinylster Glass Capsule Anchoring Adhesive

Tension Loads for Threaded Rod Anchors in Normal-Weight Concrete Stemwall
See Footnotes for Number of Capsules Per Hole



Rod Dia. in. (mm)	VGC Capsule	Drill Bit Dia. in.	Embed. Depth in. (mm)	Stemwall Width in. (mm)	Min. Edge Dist. in. (mm)	Min. End Dist. in. (mm)	Tension Load Based on Bond Strength			Tension Load Based on Steel Strength
							$f'_c \geq 2000$ psi (13.8 MPa) Concrete			F1554 Grade 36
							Ultimate lbs. (kN)	Std. Dev. lbs. (kN)	Allowable lbs. (kN)	Allowable lbs. (kN)
5/8 (15.9)	VGC62 ¹	1 1/16	12 (305)	6 (152)	1 3/4 (44)	5 (127)	13,250 (58.9)	1,590 (7.1)	3,310 (14.7)	5,875 (26.1)
7/8 (22.2)	VGC100 ²	1	15 (381)	8 (203)	1 3/4 (44)	5 (127)	20,843 (92.7)	1,883 (8.4)	5,210 (23.2)	11,500 (51.2)

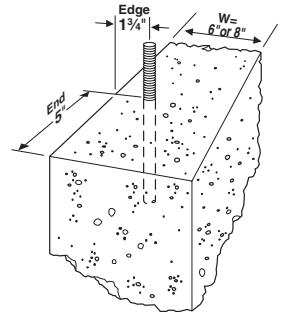

Edge and end distances for threaded rod in concrete foundation stemwall corner installation

- Requires 3 capsules per hole.
- Requires 2 capsules per hole.
- Allowable load must be the lesser of the bond or steel strength.
- The allowable loads listed under allowable bond are based on a safety factor of 4.0.
- Allowable loads may not be increased for short-term loading due to wind or seismic forces.
- Anchors are permitted to be used within fire-resistive construction, provided the anchors resist wind or seismic loads only. For use in fire-resistive construction, the anchors can also be permitted to be used to resist gravity loads, provided special consideration has been given to fire-exposure conditions.

Tension Loads for Rebar Dowels in Normal-Weight Concrete
One (1) VGC Capsule Per Hole



Rebar Size No. (mm)	VGC Capsule	Drill Bit Dia. in.	Embed. Depth in. (mm)	Critical Edge Dist. in. (mm)	Critical Spacing Dist. in. (mm)	Tension Load Based on Bond Strength			Tension Load Based on Steel Strength
						$f'_c \geq 2000$ psi (13.8 MPa) Concrete			ASTM A615 Grade 60 Rebar
						Ultimate lbs. (kN)	Std. Dev. lbs. (kN)	Allowable lbs. (kN)	Allowable lbs. (kN)
#3 (9.5)	VGC37	7/16	3 1/2 (89)	5 1/4 (133)	14 (356)	6,211 (27.6)	480 (1.8)	1,555 (6.9)	2,640 (11.7)
#4 (12.7)	VGC50	5/8	4 1/4 (108)	6 3/8 (162)	17 (432)	14,579 (64.9)	1,365 (6.1)	3,645 (16.2)	4,800 (21.4)
#5 (15.9)	VGC62	3/4	5 (127)	7 1/2 (191)	20 (508)	12,066 (53.7)	3,904 (17.4)	3,015 (13.4)	7,440 (33.1)
#6 (19.1)	VGC75	7/8	7 (178)	10 1/2 (267)	28 (711)	18,692 (83.1)	2,225 (9.9)	4,675 (20.8)	10,560 (47.0)
#7 (22.2)	VGC100	1	8 (203)	11 3/8 (295)	32 (813)	33,182 (147.6)	548 (2.4)	8,295 (36.9)	14,400 (64.1)
#8 (25.4)	VGC100	1 1/8	8 (203)	13 1/2 (343)	32 (813)	34,517 (153.5)	5,163 (23.0)	8,630 (38.4)	18,960 (84.3)

- Allowable load must be the lesser of the bond or steel strength.
- The allowable loads listed under allowable bond are based on a safety factor of 4.0.
- Allowable loads may not be increased for short-term loading due to wind or seismic forces.
- Refer to allowable load-adjustment factors for spacing and edge distance on pages 82–83.
- Anchors are permitted to be used within fire-resistive construction, provided the anchors resist wind or seismic loads only. For use in fire-resistive construction, the anchors can also be permitted to be used to resist gravity loads, provided special consideration has been given to fire-exposure conditions.
- Anchors are not permitted to resist tension forces in overhead or wall installations unless proper consideration is given to fire-exposure conditions.

Shear Loads for Rebar Dowels in Normal-Weight Concrete
One (1) VGC Capsule Per Hole



Rebar Size No. (mm)	VGC Capsule	Drill Bit Dia. in.	Embed. Depth in. (mm)	Critical Edge Dist. in. (mm)	Critical Spacing Dist. in. (mm)	Shear Load Based on Concrete Edge Distance			Shear Load Based on Steel Strength
						$f'_c \geq 2000$ psi (13.8 MPa) Concrete			ASTM A615 Grade 60 Rebar
						Ultimate lbs. (kN)	Std. Dev. lbs. (kN)	Allowable lbs. (kN)	Allowable lbs. (kN)
#3 (9.5)	VGC37	7/16	3 1/2 (89)	6 (152)	5 1/4 (133)	8,294 (36.9)	515 (2.3)	2,075 (9.2)	1,680 (7.5)
#4 (12.7)	VGC50	5/8	4 1/4 (108)	8 (203)	6 3/8 (162)	11,012 (49.0)	383 (1.7)	2,755 (12.3)	3,060 (13.6)
#5 (15.9)	VGC62	3/4	5 (127)	10 (254)	7 1/2 (191)	15,758 (70.1)	1,154 (5.1)	3,940 (17.5)	4,740 (21.1)
#6 (19.1)	VGC75	7/8	7 (178)	12 (305)	10 1/2 (267)	23,314 (103.7)	1,494 (6.6)	5,830 (25.9)	6,730 (29.9)
#7 (22.2)	VGC100	1	8 (203)	14 (356)	11 3/8 (295)	32,662 (145.3)	5,588 (24.9)	8,165 (36.3)	9,180 (40.8)
#8 (25.4)	VGC100	1 1/8	8 (203)	16 (406)	13 1/2 (343)	•	•	8,165 (36.3)	12,085 (53.8)

*See page 13 for an explanation of the load table icons

- Allowable load must be the lesser of the load based on concrete edge distance or steel strength.
- The allowable loads based on concrete edge distance are based on a safety factor of 4.0.
- Allowable loads may not be increased for short-term loading due to wind or seismic forces.
- Refer to allowable load-adjustment factors for spacing and edge distance on pages 82–83.
- Anchors are permitted to be used within fire-resistive construction, provided the anchors resist wind or seismic loads only. For use in fire-resistive construction, the anchors can also be permitted to be used to resist gravity loads, provided special consideration has been given to fire-exposure conditions.

VGC Technical Information

**Load-Adjustment Factors for VGC Glass Capsule Adhesive in Normal-Weight Concrete:
Edge Distance, Tension and Shear Loads**

How to use these charts:

1. The following tables are for reduced edge distance.
2. Locate the anchor size to be used for either a tension and/or shear load application.
3. Locate the embedment (E) at which the anchor is to be installed.
4. Locate the edge distance (C_{act}) at which the anchor is to be installed.
5. The load-adjustment factor (f_c) is the intersection of the row and column.
6. Multiply the allowable load by the applicable load-adjustment factor.
7. Reduction factors for multiple edges are multiplied together.
8. Adjustment factors do not apply to allowable steel strength values.
9. Adjustment factors are to be applied to allowable Tension Load Based on Bond Strength values or allowable Shear Load Based on Concrete Edge Distance values only.

Vinylester Adhesive

Edge Distance Tension (f_c)



Edge Dist. C_{act} (in.)	Dia.	$\frac{3}{8}$		$\frac{1}{2}$		$\frac{5}{8}$		$\frac{3}{4}$		$\frac{7}{8}$		1	
	Rebar	#3	#4	#4	#5	#5	#6	#6	#7	#7	#8	#8	#8
E		3½	7	4¼	8½	5	10	7	14	8	16	8	16
C_{cr}		5¼	10½	6¾	12¾	7½	15	10½	21	11½	24	13½	24
C_{min}		1¾	1¾	1¾	1¾	1¾	1¾	1¾	1¾	1¾	1¾	1¾	1¾
f_{cmin}		0.65	0.65	0.65	0.65	0.57	0.61	0.54	0.56	0.54	0.52	0.54	0.39
1¾		0.65	0.65	0.65	0.65	0.57	0.61	0.54	0.56	0.54	0.52	0.54	0.39
2		0.68	0.66	0.67	0.66	0.59	0.62	0.55	0.57	0.55	0.53	0.55	0.40
3		0.78	0.70	0.74	0.69	0.66	0.65	0.61	0.59	0.60	0.55	0.59	0.42
4		0.88	0.74	0.82	0.72	0.74	0.68	0.66	0.61	0.64	0.57	0.63	0.45
5		0.98	0.78	0.90	0.75	0.81	0.71	0.71	0.63	0.69	0.59	0.67	0.48
6		1.00	0.82	0.97	0.79	0.89	0.74	0.76	0.66	0.74	0.61	0.71	0.51
7			0.86	1.00	0.82	0.96	0.76	0.82	0.68	0.78	0.63	0.75	0.53
8			0.90		0.85	1.00	0.79	0.87	0.70	0.83	0.65	0.78	0.56
9			0.94		0.88		0.82	0.92	0.73	0.88	0.68	0.82	0.59
10			0.98		0.91		0.85	0.97	0.75	0.92	0.70	0.86	0.62
12			1.00		0.98		0.91	1.00	0.79	1.00	0.74	0.94	0.67
14					1.00		0.97		0.84		0.78	1.00	0.73
16							1.00		0.89		0.83		0.78
18									0.93		0.87		0.84
20									0.98		0.91		0.89
22									1.00		0.96		0.95
24											1.00		1.00

*See page 13 for an explanation of the load table icons

See Notes Below

Edge Distance Shear (f_c)

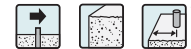

Edge Dist. C_{act} (in.)	Dia.	$\frac{3}{8}$		$\frac{1}{2}$		$\frac{5}{8}$		$\frac{3}{4}$		$\frac{7}{8}$		1	
	Rebar	#3	#4	#4	#5	#5	#6	#6	#7	#7	#8	#8	#8
E		3½	3½	4¼	4¼	5	5	7	7	8	8	8	8
C_{cr}		5¼	6	6¾	8	7½	10	10½	12	11½	14	13½	16
C_{min}		1¾	1¾	1¾	1¾	1¾	1¾	1¾	1¾	1¾	1¾	1¾	1¾
f_{cmin}		0.35	0.19	0.15	0.16	0.11	0.10	0.11	0.10	0.08	0.09	0.08	0.08
1¾		0.35	0.19	0.15	0.16	0.11	0.10	0.11	0.10	0.08	0.09	0.08	0.08
2		0.40	0.24	0.20	0.19	0.15	0.13	0.14	0.12	0.10	0.11	0.10	0.10
3		0.58	0.43	0.38	0.33	0.30	0.24	0.24	0.21	0.20	0.18	0.18	0.16
4		0.77	0.62	0.56	0.46	0.46	0.35	0.34	0.30	0.29	0.26	0.26	0.23
5		0.95	0.81	0.75	0.60	0.61	0.45	0.44	0.39	0.38	0.33	0.33	0.29
6		1.00	1.00	0.93	0.73	0.77	0.56	0.54	0.47	0.48	0.41	0.41	0.35
7				1.00	0.87	0.92	0.67	0.64	0.56	0.57	0.48	0.49	0.42
8					1.00	1.00	0.78	0.75	0.65	0.66	0.55	0.57	0.48
9							0.89	0.85	0.74	0.76	0.63	0.65	0.55
10							1.00	0.95	0.82	0.85	0.70	0.73	0.61
12								1.00	1.00	1.00	0.85	0.88	0.74
14											1.00	1.00	0.87
16													1.00

*See page 13 for an explanation of the load table icons

1. E = Embedment depth (inches).
2. C_{act} = actual edge distance at which anchor is installed (inches).
3. C_{cr} = critical edge distance for 100% load (inches).
4. C_{min} = minimum edge distance for reduced load (inches).
5. f_c = adjustment factor for allowable load at actual edge distance.
6. f_{ccr} = adjustment factor for allowable load at critical edge distance. f_{ccr} is always = 1.00.
7. f_{cmin} = adjustment factor for allowable load at minimum edge distance.
8. $f_c = f_{cmin} + [(1 - f_{cmin}) (C_{act} - C_{min}) / (C_{cr} - C_{min})]$.

VGC Technical Information

Load-Adjustment Factors for VGC Glass Capsule Adhesive in Normal-Weight Concrete: Spacing, Tension and Shear Loads

How to use these charts:

1. The following tables are for reduced spacing.
2. Locate the anchor size to be used for either a tension and/or shear load application.
3. Locate the embedment (E) at which the anchor is to be installed.
4. Locate the spacing (S_{act}) at which the anchor is to be installed.
5. The load-adjustment factor (f_s) is the intersection of the row and column.
6. Multiply the allowable load by the applicable load-adjustment factor.
7. Reduction factors for multiple spacings are multiplied together.
8. Adjustment factors do not apply to allowable steel strength values.
9. Adjustment factors are to be applied to allowable Tension Load Based on Bond Strength values or allowable Shear Load Based on Concrete Edge Distance values only.

Spacing Tension (f_s)

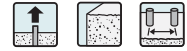

S_{act} (in.)	Dia.	$\frac{3}{8}$		$\frac{1}{2}$		$\frac{5}{8}$		$\frac{3}{4}$		$\frac{7}{8}$		1	
	Rebar	#3	#4	#5	#6	#7	#8	#8	#8	#8	#8	#8	#8
E		3½	7	4¼	8½	5	10	7	14	8	16	8	16
S_{cr}		14	28	17	34	20	40	28	56	32	64	32	64
S_{int}		6⅞	12¼	7½	14⅞	8¾	17½	12¼	24½	14	28	14	28
S_{min}		1¾	3½	2⅞	4¼	2½	5	3½	7	4	8	4	8
f_{smin}		0.58	0.58	0.58	0.58	0.58	0.58	0.58	0.58	0.58	0.58	0.58	0.58
1¼		0.58											
2		0.60											
3		0.68		0.64		0.61							
4		0.76	0.60	0.70		0.66		0.60		0.58		0.58	
6		0.92	0.68	0.83	0.64	0.78	0.61	0.68		0.65		0.65	
8		0.95	0.76	0.93	0.70	0.89	0.66	0.76	0.60	0.72	0.58	0.72	0.58
10		0.96	0.84	0.95	0.77	0.94	0.72	0.84	0.64	0.79	0.62	0.79	0.62
14		1.00	0.94	0.98	0.90	0.96	0.83	0.94	0.72	0.93	0.69	0.93	0.69
18			0.96	1.00	0.94	0.99	0.93	0.96	0.80	0.95	0.76	0.95	0.76
22			0.97		0.96	1.00	0.94	0.97	0.88	0.96	0.83	0.96	0.83
26			0.99		0.97		0.96	0.99	0.93	0.98	0.90	0.98	0.90
30			1.00		0.99		0.97	1.00	0.94	0.99	0.93	0.99	0.93
35					1.00		0.98		0.95	1.00	0.94	1.00	0.94
40							1.00		0.96		0.95		0.95
45									0.98		0.96		0.96
50									0.99		0.97		0.97
55									1.00		0.98		0.98
60											0.99		0.99
65											1.00		1.00

*See page 13 for an explanation of the load table icons

See Notes Below

Spacing Shear (f_s)



S_{act} (in.)	Dia.	$\frac{3}{8}$	$\frac{1}{2}$	$\frac{5}{8}$	$\frac{3}{4}$	$\frac{7}{8}$	1
	Rebar	#3	#4	#5	#6	#7	#8
E		3½	4¼	5	7	8	8
S_{cr}		5¼	6⅞	7½	10½	11⅞	13½
S_{min}		1¾	2⅞	2½	3½	4	4
f_{smin}		0.83	0.83	0.83	0.83	0.83	0.83
1¼		0.83					
2		0.84					
3		0.89	0.87	0.85			
4		0.94	0.91	0.88	0.84	0.83	0.83
5		0.99	0.95	0.92	0.87	0.85	0.85
6		1.00	0.99	0.95	0.89	0.87	0.87
7			1.00	0.98	0.92	0.90	0.88
8				1.00	0.94	0.92	0.90
9					0.96	0.94	0.92
10					0.99	0.96	0.94
12					1.00	1.00	0.97
14							1.00

*See page 13 for an explanation of the load table icons

1. E = Embedment depth (inches).
2. S_{act} = actual spacing distance at which anchors are installed (inches).
3. S_{cr} = critical spacing distance for 100% load (inches).
4. S_{min} = minimum spacing distance for reduced load (inches).
5. S_{int} = intermediate spacing distance at which anchors are installed (inches).
6. f_s = adjustment factor for allowable load at actual spacing distance.
7. f_{scr} = adjustment factor for allowable load at critical spacing distance. f_{scr} is always = 1.00.
8. f_{smin} = adjustment factor for allowable load at minimum spacing distance.
9. $f_s = f_{smin} + [(1 - f_{smin}) (S_{act} - S_{min}) / (S_{cr} - S_{min})]$.

Crack-Repair Adhesive Systems



A proud, old hospital was crumbling. Since its construction in the early 1900s, the ravages of time and seismic activity had left hundreds of cracks that threatened to undermine the structural health of the facility. Utilizing crack repair adhesive systems from Simpson Strong-Tie helped to repair and contribute to the structural integrity of the building – ultimately extending the life of the hospital.

Simpson Strong-Tie offers reliable, easy-to-dispense products for a variety of restoration applications, including structural restoration, pick-proof sealing and water-intrusion prevention.



ETI Injection Epoxy

ETI injection epoxies are specially designed formulations for the injection of cracks in concrete. ETI epoxies are two-component, high-solids formulations. They are available in side-by-side cartridges and are dispensed through a static mixing nozzle using a standard dispensing tool. ETI is available in three viscosities: ETI-LV (low viscosity), ETI-GV (gel viscosity) and ETI-SLV (super-low viscosity) to handle a wide range of crack widths. Properly installed, they provide a repair that is both waterproof and high strength (structural).

FEATURES:

- Chemically bonds with the concrete to provide a structural repair (meets the requirements of ASTM C-881 as a structural repair epoxy)
- Seals the crack from moisture, protecting rebar in the concrete from corrosion and flooring from moisture damage
- All viscosities formulated for maximum penetration under pressure
- Side-by-side cartridge dispensing provides reliable mixing and ratio control when used with the Opti-Mix® static mixing nozzle
- Eliminates the need for expensive bulk dispensing equipment
- Suitable for pressure injection or gravity-feed applications
- Non-shrink material resistant to oils, salts and mild chemicals

ETI-SLV Super-Low Viscosity Injection Epoxy

- Super-low viscosity (350cps) for repair of hairline cracks and cracks up to 1/4"
- Penetrates the smallest cracks
- Suitable for structural repairs

ETI-LV Low Viscosity Injection Epoxy

- Low viscosity epoxy (1790 cps) for repair of fine to medium width cracks 1/64"-1/4" in width
- Low surface tension allows the material to effectively penetrate narrow cracks
- Suitable for structural repairs

ETI-GV Gel Viscosity Injection Epoxy

- Gel viscosity epoxy for repair of medium cracks 3/32"-1/4" in width.
- Decreases in viscosity under pressure for increased flowability.
- Suitable for structural repairs.

APPLICATION: Injection epoxies are suitable for repairing non-moving cracks in concrete walls, floors, slabs, columns and beams. They can be used to inject cracks in damp or wet conditions (water cannot be flowing out of crack) with excellent results. Apply to concrete 40°F or above. For best results, warm material to 60°F or above prior to application.

SHELF LIFE: 24 months in unopened cartridge

STORAGE CONDITIONS: For best results, store between 45°-90°F

CURED: ETI-SLV, ETI-LV: Black, ETI-GV: Gray

CLEAN UP: Removal of cured adhesive – Chip or grind off surface. Uncured Adhesive – Wipe up with cotton cloths. If desired, scrub area with abrasive, waterbased cleaner and flush with water. If approved, solvents such as ketones (MEK, acetone, etc.), lacquer thinner, or adhesive remover can be used. **DO NOT USE SOLVENTS TO CLEAN ADHESIVE FROM SKIN.** Take appropriate precautions when handling flammable solvents. Solvents may damage surface to which they are applied.

TECHNICAL SPECIFICATIONS:

- **ETI-SLV:** Meets the requirements of ASTM C-881 Type I, and IV, Grade 1, Classes B & C.
- **ETI-LV:** Meets the requirements of ASTM C-881 Type I, II, IV and V, Grade 1, Classes B & C. Approved under NSF/ANSI Standard 61 (22 in²/1000 gal).
- **ETI-GV:** Meets the requirements of ASTM C-881 Type I, II, IV and V, Grade 3, Classes B & C.

CHEMICAL RESISTANCE: Very good to excellent against distilled water, inorganic acids and alkalis. Fair to good against organic acids and alkalis, and many organic solvents. Poor against ketones.

ACCESSORIES: See page 94 for information on mixing nozzles, parts, fittings and paste over material.



Caution – The ETI-LV must be used with the Opti-Mix® nozzle (EMN022) for proper mixing. ETI-GV may also be used with the EMN22i mixing nozzle for gravity feed applications in large cracks.

ETI Cartridge System

Model No.	Capacity ounces (cubic inches)	Cartridge Type	Carton Quantity	Dispensing Tool	Mixing ¹ Nozzle
ETISLV	16.5 29.8	side-by-side	10	EDT22S ³	EMN022 (included)
ETILV22	22 (39.7)	side-by-side	10	EDT22S	
ETIGV22					

1. Bulk containers also available, call Simpson Strong-Tie for details.
2. Use only appropriate Simpson Strong-Tie® mixing nozzle in accordance with Simpson Strong-Tie instructions. Modification or improper use of mixing nozzle may impair epoxy performance.
3. EDT22S tool needs to be configured for 2:1 cartridge ratio.

IMPORTANT – See Pages 88–89 for Installation Instructions

PROPERTY	TEST METHOD	ETI-SLV RESULTS	ETI-LV RESULTS	ETI-GV RESULTS
Viscosity (75°F)	ASTM D 2393	350 cps	1,790 cps	Non-sag gel
Bond strength (moist cure)	ASTM C 882	3,100 psi (2 days)	2,500 psi (2 days)	1,109 psi (2 days)
		3,900 psi (14 days)	2,530 psi (14 days)	3,994 psi (14 days)
Tensile strength	ASTM D 638	10,200 psi	7,470 psi (7 days)	—
Tensile elongation at break	ASTM D 638	2.10%	9.4%	—
Compressive yield strength	ASTM D 695	16,500 psi	12,480 psi (7 days)	11,564 psi (7 days)
Compressive modulus	ASTM D 695	569,000 psi	342,000 psi	403,200 psi
Deflection temperature	ASTM D 648	140°F	130°F	131°F
Water absorption (24 hrs)	ASTM D 570	0.25%	0.76%	0.58%
Linear coefficient of shrinkage	ASTM D 2566	0.0035	0.004	0.000
Gel time (60 gram mass)	ASTM D 881	16 min.	100 min.	135 min.
Initial cure (72°F)	—	24 hours	24 hours	24 hours

CRACK-PAC® Injection Epoxy

The Crack-Pac® two-part, high solids, low-viscosity crack injection epoxy is designed to repair cracks in concrete. The mixed adhesive has the viscosity of a light oil and a low surface tension that enables it to penetrate fine to medium width cracks. Resin is contained in the cartridge and hardener is contained in the nozzle. Once the nozzle is threaded onto the cartridge, the hardener is released into the resin-filled cartridge by turning the knob at the base of the nozzle. The two components are mixed by shaking the cartridge.

FEATURES:

- Dispenses with a standard caulking tool, no dedicated dispensing tool needed
- Low viscosity
- Clean and easy mixing; no additional tools required
- Chemically bonds with the concrete to restore strength
- Resistant to oils, salts and mild chemicals
- Non-shrink
- Conforms to of ASTM C-881 Type I & II, Grade 1, Classes B & C

APPLICATION: Suitable for repair of cracks ranging from 1/64" to 1/4" wide in concrete walls, floors, slabs, columns and beams. Can be used to inject cracks in dry, damp or wet conditions with excellent results. Not for use in actively leaking cracks. Apply to concrete 40°F or above.

SHELF LIFE: 24 months from date of manufacture, unopened

USAGE TEMPERATURE: In order for components to mix properly, the resin and hardener must be conditioned to 60°-80°F before mixing.

STORAGE CONDITIONS: For best results, store between 45°F - 95°F

COLOR: Resin - blue, hardener - clear, mixed: light amber. The color of epoxy will change from amber to blue during the cure process and then fade back to light amber within a few weeks of installation.

CLEAN UP: Wipe up with cotton cloths. If desired scrub area with abrasive, waterbased cleaner and flush with water. If approved, solvents such as ketones (MEK, acetone, etc.), laquer thinner, or adhesive remover can be used. **DO NOT USE SOLVENTS TO CLEAN ADHESIVE FROM SKIN.** Take appropriate precautions when handling flammable solvents. Solvents may damage surfaces to which they are applied. Cured material – Chip or grind off surface.

PROPERTY	TEST METHOD	RESULTS
Viscosity (mixed, 72°F)	ASTM D 2393	1,400 cps
Bond strength (moist cure)	ASTM C 882	2,010 psi (2 days) 3,830 psi (14 days)
Water absorption	ASTM D 570	0.082% (24 hrs)
Tensile strength	ASTM D 638	5,860 psi (7 days)
Elongation at ultimate	ASTM D 638	14.1%
Compressive yield strength	ASTM D 695	11,270 psi (7 days)
Compressive modulus	ASTM D 695	318,600 psi
Linear coefficient of shrinkage	ASTM D 2566	0.002
Gel time (72°F)	ASTM C 881	2 hours - 60 g mass
Initial cure (72°F)		24 hours
Mixing ratio		8:1

CHEMICAL RESISTANCE: Very good to excellent against distilled water, inorganic acids and alkalis. Fair to good against organic acids and alkalis, and many organic solvents. Poor against ketones.

Crack-Pac® Cartridge System

Model No.	Capacity ounces (cubic inches)	Cartridge Type	Carton Quantity	Dispensing Tool(s)
ETIPAC10	9 (16.2)	single	12	CDT10S or standard caulking tool
ETIPAC10KT	18 (32.4)	single	2 (kits)	

ACCESSORIES: See page 94 for information on mixing nozzles, parts, fittings and paste over material.



Crack-Pac® Injection Epoxy (ETIPAC10)
Dispensing Systems: U.S. Patents 6,737,000 and 6,896,001 B2



Crack-Pac® Kit (ETIPAC10KT)



Crack-Pac® Kit Components

Crack-Pac® injection epoxy is also available in the Crack-Pac Injection Kit. The kit includes everything needed to pressure inject approximately 8 lineal feet of cracks:

- 2 Crack-Pac cartridge/nozzle sets
- 12 E-Z-Click™ injection ports
- 2 E-Z-Click™ injection fittings with 12" tubing
- 1 pint of paste-over epoxy (8 oz. of resin + 8 oz. of hardener)
- 4 disposable wood paste-over applicators
- 1 pair latex gloves
- Installation video



Crack-Pac® injection epoxy using the E-Z-Click Port System

IMPORTANT – See Pages 87–89 for Installation Instructions



Wear gloves when handling the Crack-Pac® cartridge once the resin and hardener are mixed, as material may become hot. Eye protection is recommended.

CARTRIDGE PREPARATION AND MIXING INSTRUCTIONS:

Usage tip: After the product is mixed, a small volume of air will remain in the cartridge. Keeping this cushion of air at the back of the cartridge during dispensing will allow the dispensing of the final bit of epoxy from the nozzle once the cartridge is empty.

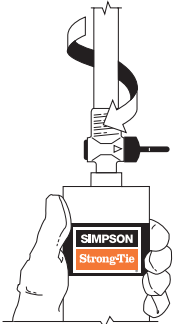
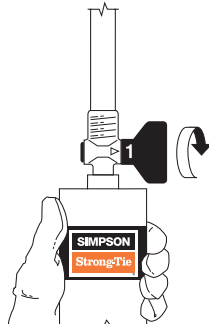
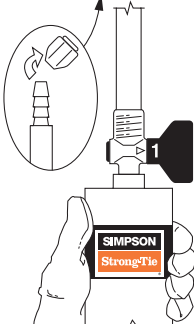
1. Remove the red cap from the top of the cartridge. 
2. Screw the threaded portion of the nozzle into the cartridge. 
3. Turn the black valve so that the #1 on the valve aligns with the arrow on the neck of the nozzle. 
4. Twist off the tip of the nozzle and allow the material contained within to drain into the cartridge. 

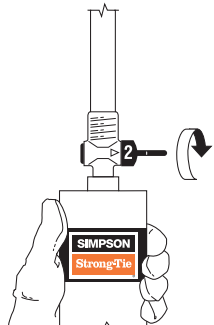
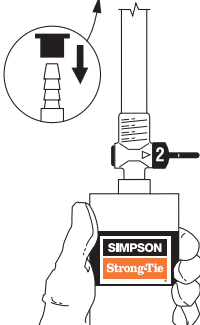
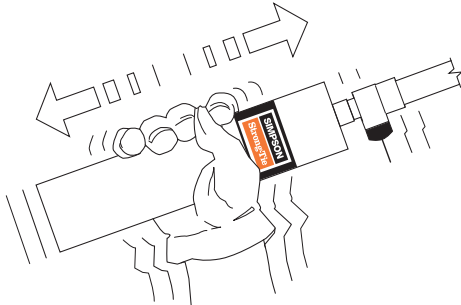
5. Turn the black valve to the #2 position. 
6. Attach the clear cap securely to the end of the nozzle. 
7. Shake the cartridge at a rate of 2 shakes per second for 2 minutes or until the mixed material is a uniform color. 

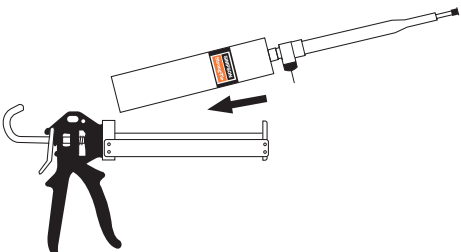
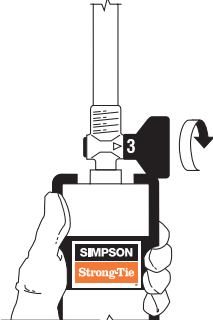
8. Insert the cartridge into the caulking tool. 
9. Turn the black valve to the #3 position and remove the black cap from the end of the nozzle. If performing gravity feed, the material is ready to dispense. If performing pressure injection, attach the E-Z-Click™ injection fitting to the end of the nozzle. 



Warning: Do not mix product until ready to use within 30 minutes. A full cartridge of mixed epoxy will harden in 65–75 minutes and will reach a peak temperature of 350°F (177°C) within two hours. To prevent pressure build up possibly resulting in cartridge breach and injury, remove cartridge from the caulking tool when not dispensing. Use caution handling or disposing of cartridge until cool.

EPOXY Injection Guide



Important: These instructions are intended as recommended guidelines. Due to the variability of field conditions, selection of the proper material for the intended application and installation are the sole responsibility of the applicator.

Epoxy injection is an economical method of repairing non-moving cracks in concrete walls, slabs, columns and piers and is capable of restoring the concrete to its pre-cracked strength. Prior to doing any injection it is necessary to determine the cause of the crack. If the source of cracking has not been determined and remedied, the concrete may crack again.

Materials

- ETI-SLV for repair of hairline cracks and cracks up to 1/4"
- ETI-LV for repair of fine to medium-width cracks (Suggested width range: 1/6"–1/4")
- ETI-GV for repair of medium-width cracks (Suggested width range: 3/32"–1/4")
- Crack-Pac® injection epoxy for repair of fine to medium non-structural cracks (Suggested width range: 1/6"–1/4")
- CIP, CIP-F and ETR are recommended for paste-over of crack surface and installation of injection ports. ET, EDOT, ETR or SET adhesives may also be used as a substitute. (SET is the only paste-over epoxy approved for NSF/ANSI Standard 61.)
- E-Z-Click™ injection ports, fittings and other suitable accessories

Preparation of the Crack for Injection

Clean the crack and the surface surrounding it to allow the epoxy to bond to sound concrete. At a minimum, the surface to receive paste-over should be brushed with a wire brush. Oil, grease or other surface contaminants must be removed in order to allow the paste-over to bond properly. Take care not to impact any debris into the crack during cleaning. Using clean, oil free compressed air, blow out the crack to remove any dust, debris or standing water. Best results will be obtained if the crack is dry at the time of injection. If water is continually seeping from the crack, the flow must be stopped in order for epoxy injection to yield a suitable repair. Other materials such as polyurethane resins may be required to repair an actively leaking crack.

For many applications, additional preparation is necessary in order to seal the crack. Where a surfacing material has been removed using an acid or chemical solvent, prepare the crack as follows:

1. Using clean, compressed air, blow out any remaining debris and liquid.
2. Remove residue by high-pressure washing or steam cleaning.
3. Blow any remaining water from the crack with clean compressed air.

If a coating, sealant or paint has been applied to the concrete it must be removed before placing the paste-over epoxy. Under the pressure of injection these materials may lift and cause a leak. If the surface coating is covering the crack, it may be necessary to route out the opening of the crack in a "V" shape using a grinder in order to get past the surface contamination.

Sealing of the Crack and Attachment of E-Z-Click™ injection ports

1. To adhere the port to the concrete, apply a small amount of epoxy around the bottom of the port base. Place the port at one end of the crack and repeat until the entire crack is ported. As a rule of thumb, injection ports should be placed 8" apart along the length of the crack. *Important: Do not allow epoxy to block the port or the crack under it, this is where epoxy must enter the crack.*



2. Using a putty knife or other paste-over tool, generously work epoxy along the entire length of the crack. Take care to mound the epoxy around the base of the port to approximately 1/4" thick extending 1" out from the base of the port and to work out any holes in the material. It is recommended that the paste-over should be a minimum of 3/16" thick and 1" wide along the crack. Insufficient paste-over will result in leaks under the pressure of injection. If the crack passes completely through the concrete element, seal the back of the crack, if possible. If not, epoxy may be able to run out the back side of the crack, resulting in an ineffective repair.



3. Allow the paste-over to harden before beginning injection.

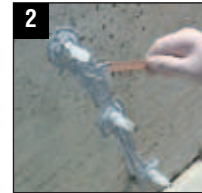

Note: CIP, CIP-F and ETR epoxies are fast cure, manually mixed materials and may harden prematurely if left in a mixed mass on the mixing surface while installing ports. Spreading paste-over into a thin film (approximately 1/8") on the mixing surface will slow curing by allowing the heat from the reaction to dissipate.

Injection Procedure for ETI-SLV, ETI-LV, ETI-GV and Crack-Pac® Injection Epoxy

1. Follow cartridge preparation instructions on the cartridge label. Verify that the material flowing from the Opti-Mix® mixing nozzle is a uniform black color for ETI-SLV, ETI-LV and a uniform gray color for ETI-GV. For Crack-Pac® injection epoxy verify that the mixed material in the cartridge is a light amber color.
2. Attach the E-Z-Click™ fitting to the end of the nozzle by pushing the tubing over the barbs at the end of the nozzle. Make sure that all ports are pushed in to the open position.
3. Attach the E-Z-Click™ injection fitting to the first E-Z-Click™ port until it clicks into place. Make sure that the heads of all the ports are pushed in to the open position. In vertical applications, begin injection at the lowest port and work your way up. In a horizontal application start at one end of the crack and work your way to the other end.



4. Inject epoxy into the first port until it will no longer flow into the crack. If epoxy shows at the next port and the first port still accepts material, close the second port and continue to inject into the first port until it accepts no more epoxy. Continue closing ports where epoxy appears until the first port refuses epoxy. When the first port reaches the point of refusal, brace the base of the port and pull

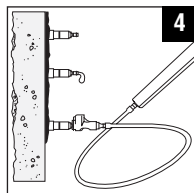

gently on the head of the port to close it. Pulling too hard may dislodge the port from the surface of the concrete, causing a leak. Depress the metal tab on the head of the E-Z-Click fitting and remove it from the port.

5. Go to the last port where epoxy appeared while injecting the first port, open it, and continue injection at this port. If the epoxy has set up and the port is bonded closed, move to the next clean port and repeat the process until every portion of the crack has refused epoxy.

While this method may appear to leave some ports uninjected, it provides maximum pressure to force the epoxy into the smaller areas of the crack. Moving to the next port as soon as epoxy appears will allow the epoxy to travel along the wider parts of the crack to the next ports rather than force it into the crack before it travels to the next ports.

Injection Tips

- If using a pneumatic dispensing tool, set the tool at a low setting when beginning injection and increase pressure if necessary to get the epoxy to flow.
- For narrow cracks it may be necessary to increase the pressure gradually until the epoxy begins to flow. It may also be necessary to wait a few minutes for the epoxy to fill the crack and travel to the next port.
- If desired, once the injection epoxy has cured, remove the injection ports and paste-over epoxy. The epoxy can be removed with a chisel, scraper, or grinder. The paste-over can be simply peeled off if CIP-F is used. Using a heat gun to soften the epoxy is recommended when using a chisel or scraper.
- Mixing nozzles can be used for multiple cartridges as long as the epoxy does not harden in the nozzle.

EPOXY Injection Guide

Troubleshooting

Epoxy is flowing into the crack, but not showing up at the next port.

This can indicate that either the crack expands and/or branches off under the surface of the concrete. Continue to inject and fill these voids. In situations where the crack penetrates completely through the concrete element and the backside of the concrete element cannot be sealed (e.g. basement walls, or footings with backfill) longer injection time may not force the epoxy to the next port. This most likely indicates that epoxy is running out of the unsealed back side of the crack. In this case the application may not be suitable for epoxy injection repair without excavation and sealing of the back side of the crack.

Back pressure is preventing epoxy from flowing.

This can indicate several situations:

- The crack is not continuous and the portion being injected is full (see above instructions about injection after the port has reached refusal).
- The port is not aligned over the crack properly.
- The crack is blocked by debris.
- If the mixing nozzle has been allowed to sit for a few minutes full of epoxy, the material may have hardened in the nozzle. Attach the E-Z-Click™ fitting to a port at another uninjected location on the crack and attempt to inject. If the epoxy still won't flow, chances are the epoxy has hardened in the nozzle.

Epoxy is leaking from the pasted-over crack or around injection ports.

Stop injecting. If using a fast cure paste-over material (ETR or CIP), wipe off the leaking injection epoxy with a cotton cloth and re-apply the paste over material. Wait approximately 10–15 minutes to allow the epoxy to begin to harden. If the leak is large (e.g. the port broke off of the concrete surface) it is a good idea to wait approximately 30 minutes, or longer as necessary, to allow the paste over to cure more completely. Check to see that the epoxy is hard before reinjecting or the paste-over or ports may leak. Another option for small leaks is to clean off the injection epoxy and use paraffin or crayon to seal the holes.

More epoxy is being used than estimated.

This may indicate that the crack either expands or branches off below the surface. Continue to inject and fill these voids. This may also indicate that epoxy is running out of the back side of the crack. If the crack penetrates completely through the concrete element and cannot be sealed, the application may not be suitable for injection repair.

Less epoxy is being used than estimated.

This may indicate that the crack is shallower than originally thought, or the epoxy is not penetrating the crack sufficiently before moving to the next port. Reinject some ports with a lower viscosity epoxy to see if the crack will take more epoxy. Another option is to heat the epoxy to a temperature of 80–100°F which will reduce its viscosity and allow it to penetrate into small cracks easier. The epoxy should be heated uniformly, do not overheat cartridge.

Gravity-Feed Procedure

Some horizontal applications where complete penetration is not a requirement can be repaired using the gravity feed method.

1. Follow cartridge preparation instructions on the cartridge label. Verify that the material flowing from the Opti-Mix® mixing nozzle is a uniform black color for ETI-SLV and ETI-LV and a uniform gray color for ETI-GV. For Crack-Pac® injection epoxy verify that the mixed material in the cartridge is a clear amber color.
2. Starting at one end of the crack, slowly dispense epoxy into the crack, moving along the crack as it fills. It will probably be necessary to do multiple passes in order to fill the crack. It is possible that the epoxy will take some time to run into the crack, and the crack may appear empty several hours after the initial application. Reapply the epoxy until the crack is filled. In situations where the crack completely penetrates the member (e.g. concrete slab) the material may continue to run through the crack into the subgrade. In these cases epoxy repair may not provide an effective repair.

Estimating Guide for Epoxy Crack Injection

Width of Crack (in.)	Concrete Thickness (in.)	Approx. Coverage per 22 oz. Cartridge (linear ft.)	Approx. Coverage per 16.5 oz. Cartridge (linear ft.)	Approx. Coverage per 9 oz. Crack-Pac Cartridge (linear ft.)
1/64	4	47.7	35.7	18.4
	6	31.8	23.8	12.3
	8	23.8	17.9	9.2
	10	19.1	14.3	7.4
1/32	4	23.8	17.9	9.2
	6	15.9	11.9	6.1
	8	11.9	8.9	4.6
	10	9.5	7.1	3.7
1/16	4	11.9	8.9	4.6
	6	7.9	6.0	3.1
	8	6.0	4.5	2.3
	10	4.8	3.6	1.8
1/8	4	6.0	4.5	2.3
	6	4.0	3.0	1.5
	8	3.0	2.2	1.2
	10	2.4	1.8	0.9
3/16	4	4.0	3.0	1.5
	6	2.6	2.0	1.0
	8	2.0	1.5	0.8
	10	1.6	1.2	0.6
1/4	4	3.0	2.2	1.2
	6	2.0	1.5	0.8
	8	1.5	1.1	0.6
	10	1.2	0.9	0.5

Coverage listed is approximate and will vary depending on waste and condition of concrete.

Tip: For narrow cracks, run a bead of caulk along each side of the crack approximately 1/8" from the edge of the crack. This will form a reservoir into which epoxy can be dispensed. Alternatively, use a grinder to route the crack opening into a "V" shape. Take care to clean the crack with compressed air afterwards as grinding can impact dust and debris into the crack and prevent proper flow of the epoxy.

Simpson Strong-Tie does not recommend repair of cracks larger than 1/4" wide without consulting a qualified engineer.

CRACK-PAC® FLEX-H₂O™ Polyurethane Crack Sealer

Crack-Pac® Flex-H₂O™ is a high solids hydrophobic polyurethane injection resin designed to seal leaking cracks, voids or fractures in concrete or solid masonry. The polyurethane is packaged in the cartridge and an accelerator is packaged in the nozzle. When the two are combined in the cartridge and mixed, the result is a low viscosity, water activated polyurethane. When the resin encounters water as it is injected into the crack, it becomes an expanding foam that provides a flexible seal in leaking and non-leaking cracks.

FEATURES:

- Seals seeping or mildly leaking cracks
- 400% elongation provides a flexible seal for moving cracks
- Can be dispensed with a standard caulking tool
- Can also be used on dry cracks
- Can be used with a reduced amount or without accelerator to slow down reaction time
- Expands to fill voids and seal the affected crack
- Expanding nature makes it suitable for sealing cracks in solid masonry
- Fast reacting - reaction begins within 1 minute after exposure to moisture; expansion may be completed within 3 minutes (depending on the amount of moisture and the ambient temperature).
- Non-shrinking hydrophobic formula with the elongation and flexibility of a hydrophilic resin
- 20:1 expansion ratio (unrestricted rise) means less material needed

APPLICATION: Suitable for sealing cracks ranging from 1/32" to 1/4" wide in concrete and solid masonry. Can be used to repair cracks in dry, damp and wet conditions with excellent results. Designed to perform in applications where water is seeping or mildly leaking from the crack. Apply to concrete 40°F or above.

SHELF LIFE: 12 months from the date of manufacture, unopened.

USAGE TEMPERATURE: In order for components to mix properly, condition to 60°F – 90°F before mixing.

STORAGE CONDITIONS: For best results store in a dry area between 45°- 95°F. Product is very moisture sensitive.

COLOR: Polyurethane - clear, accelerator - green, cured - green

CLEAN UP: Uncured material – Wipe up with cotton cloths. If desired scrub area with abrasive, waterbased cleaner and flush with water. If approved, solvents such as ketones (MEK, acetone, etc.), lacquer thinner, or adhesive remover can be used. **DO NOT USE SOLVENTS TO CLEAN ADHESIVE FROM SKIN.** Take appropriate precautions when handling flammable solvents. Solvents may damage surfaces to which they are applied. Cured material – scrape or brush off surface with a putty knife or wire brush. Tip: wetting the concrete or masonry surface immediately prior to injection will make cured resin easier to remove.

PROPERTY	TEST METHOD	RESULTS
Viscosity (77°F)	ASTM D 1638	600 cps (liquid state)
Density	ASTM D 1622	Highly restricted rise - 65 lbs./ft ³ Lightly restricted rise - 10 lbs./ft ³
Elongation	ASTM D 638	Highly restricted rise - 400% Lightly restricted rise - 400%
Tensile strength	ASTM D 638	Highly restricted rise - 2200 psi Lightly restricted rise - 300 psi
Tear strength	ASTM D 624	Highly restricted rise - 400 psi Lightly restricted rise - 55 psi

CHEMICAL RESISTANCE

Very good to excellent against water, most hydrocarbons and alkalis. Poor to fair against ketones, chlorinated solvents and concentrated acids.

Additional Components Needed for Crack Repair

Condition	Paste-Over Material	Ports
Dry Crack	ETR, CIP or CIP-F*	EIP-EZA
Wet Crack		
Seeping Crack	Hydraulic Cement	EIPX-EZ Drill-In
Mildly Leaking Crack		

*CIP-F requires EIP-EZA port.
See page 94 for information on Crack Repair Accessories.

DEFINITIONS:

- Dry Crack:** A crack containing no moisture.
Wet Crack: A crack containing moisture (damp or containing standing water). The surface can be dried and will remain dry during the paste-over operation.
Seeping Crack: A wet crack that slowly oozes water. After being dried, the surface slowly becomes wet again.
Mildly Leaking Crack: A crack with a slow trickle of water emitting from its face.



Crack-Pac® Flex-H₂O™ Crack Sealer

Dispensing System: U.S. Patents 6,737,000 and 6,896,001 B2



For Leaking Cracks



Crack-Pac® Flex-H₂O™ Kit (CPFH09KT)



Crack-Pac® Flex-H₂O™ Kit Components

Crack-Pac® Flex-H₂O™ crack sealer is also available in the Crack-Pac Flex-H₂O Injection Kit. The kit includes everything needed to pressure inject approximately 8 lineal feet of cracks:

- 2 Crack-Pac Flex-H₂O cartridge/nozzle sets
- 1 pint of paste-over epoxy (8 oz. of resin + 8 oz. of hardener)
- 2 E-Z-Click™ injection ports
- 4 disposable wood paste-over applicators
- 1 pair latex gloves

Crack-Pac® Flex-H₂O™ Cartridge System

Model No.	Capacity ounces (cubic inches)	Cartridge Type	Carton Quantity	Dispensing Tool(s)
CPFH09	9 (16.2)	single	12	CDT10S or Standard Caulking Tool
CPFH09KT	18 (32.4)	single	2 (kits)	

Crack-Pac® Flex-H₂O™ Bulk Packaging

Model No.	Description	Capacity	Dispensing Tool/Equipment
FH05*	Flex-H ₂ O Resin	5 Gallons	Bulk Pump/Meter Mix Machine or Grease Gun
	Flex-H ₂ O Catalyst	16 Ounces	

*For standard reaction time, use a 30:1 resin: catalyst ratio. For a faster reaction time, add more catalyst, for a slower reaction time, use less.

ACCESSORIES: See pages 94 for information on mixing nozzles, parts, fittings and paste over material.

IMPORTANT – See Pages 91–93 for Installation Instructions



Wear gloves when handling the Crack-Pac® Flex-H2O™ cartridge. Eye protection is recommended.

CARTRIDGE PREPARATION AND MIXING INSTRUCTIONS:

Usage tip: After the product is mixed, a small volume of air will remain in the cartridge. Keeping this cushion of air at the back of the cartridge during dispensing will allow the dispensing of the final bit of epoxy from the nozzle once the cartridge is empty.

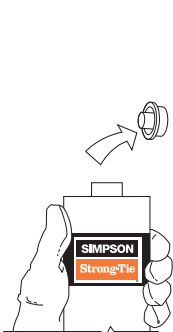

1. Remove the red cap from the top of the cartridge.

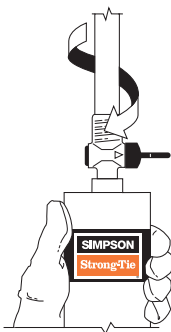

2. Screw the threaded portion of the nozzle into the cartridge.

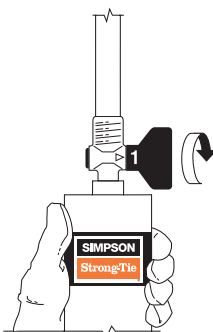

3. Turn the black valve so that the #1 on the valve aligns with the arrow on the neck of the nozzle.

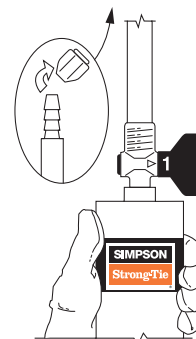

4. Twist off the tip of the nozzle and allow the material contained within to drain into the cartridge.

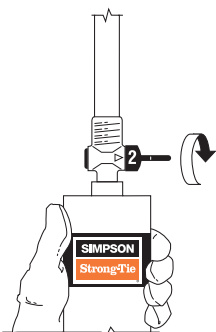

5. Turn the black valve to the #2 position.

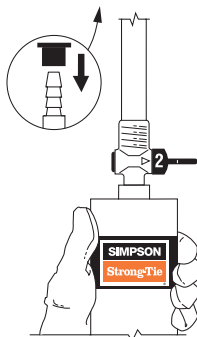

6. Attach the black cap securely to the end of the nozzle.

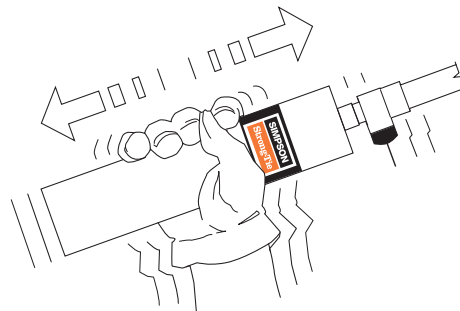

7. Shake the cartridge at a rate of 2 shakes per second for 2 minutes or until the mixed material is a uniform color.

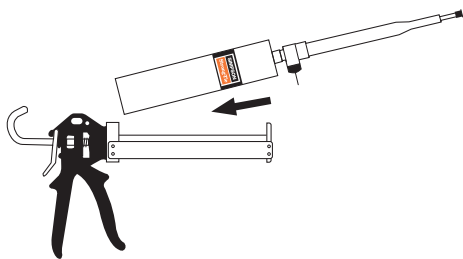

8. Insert the cartridge into the caulking tool.

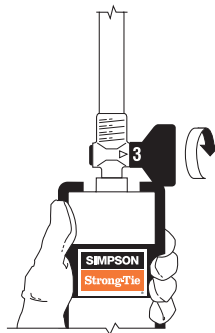

9. Turn the black valve to the #3 position and remove the black cap from the end of the nozzle. Attach the E-Z-Click™ injection fitting to the end of the nozzle for injection.



Warning: Do not open cartridge until ready to use. The polyurethane will react to atmospheric moisture if left exposed. To prevent pressure build up possibly resulting in cartridge breach and injury, remove cartridge from the caulking tool when not dispensing.

CRACK-PAC® FLEX-H₂O™ Injection Guide

Important: These instructions are intended as recommended guidelines. Due to the variability of field conditions, selection of the proper material for the intended application and installation are the sole responsibility of the applicator.

Application

Polyurethane injection is an effective and economical method of sealing cracks in concrete and solid masonry elements. Crack-Pac® Flex-H₂O™ crack sealer is suitable for sealing dry, wet, seeping and mildly leaking cracks in horizontal and vertical concrete and solid masonry elements ranging from 1/32" - 1/4".

Definitions:

Dry Crack—a crack containing no moisture

Wet Crack—a crack containing moisture (damp or containing standing water). The surface can be dried and will remain dry during the paste-over operation.

Seeping Crack—a wet crack that slowly oozes water. After being dried, the surface slowly becomes wet again.

Mildly Leaking Crack—a crack with a slow trickle of water emitting from its face.

NOTE: Multiple applications may be necessary to fill all voids.

Preparing the Crack for Injection

Clean the crack and the surface surrounding it to allow the paste-up material to bond to sound concrete. At a minimum, the surface to receive paste-over should be brushed with a wire brush. Oil, grease or other surface contaminants must be removed in order to allow the paste-over to bond properly. Take care not to impact any debris into the crack during cleaning. With dry cracks, use clean, oil free compressed air to blow out as much dust and debris from the crack.

For many applications, additional preparation is necessary in order to seal the crack. Where a surfacing material has been removed using an acid or chemical solvent, prepare the crack as follows:

1. Using clean, compressed air, blow out any remaining debris and liquid.
2. Remove residue by high-pressure washing or steam cleaning.
3. Blow any remaining water from the crack with clean compressed air.

If a coating, sealant or paint has been applied to the concrete it must be removed before placing the paste-over material. Under the pressure of injection these materials may lift and cause a leak. If the surface coating is covering the crack, it may be necessary to route out the surface of the crack in a "V" shape using a grinder in order to get past the surface contamination.

Dry or Wet Crack Application - Sealing of the crack and attachment of E-Z-Click™ flush mount injection ports (Model EIP-EZ or EIP-EZA)

1. To adhere the port to the concrete, apply a small amount of epoxy around the bottom of the port base. Place the port at one end of the crack and repeat until the entire crack is ported. As a rule of thumb, injection ports should be placed 8" apart along the length of the crack. Important: Do not allow epoxy to block the port or the crack under it, this is where adhesive must enter the crack.
2. Using a putty knife or other paste-over tool, generously work epoxy along the entire length of the crack. Take care to mound the epoxy around the base of ports and to work out any holes in the material. It is recommended that the paste-over should be a minimum of 1/8" thick and 1" wide. Insufficient paste-over will result in leaks under the pressure of injection. Allow the paste-over to cure before beginning injection.
3. For Dry Cracks- Crack-Pac Flex-H₂O reacts with water and needs moisture present to cure. Therefore, if the crack to be sealed is completely dry, water must be introduced into it. Once ports are in place and the crack surface is pasted over, use a syringe or spray bottle to introduce approximately 1 ounce of water into each port.



Note: CIP and CIP-F and ETR epoxies are a fast cure, manually mixed materials and may harden prematurely if left in a mixed mass on the mixing surface while installing ports. Spreading paste-over into a thin film (approximately 1/8") on the mixing surface will slow curing by allowing the heat from the reaction to dissipate.

Seeping Crack Application - Sealing of the crack and attachment of E-Z-Click flush mount injection ports (Model EIP-EZ)

1. Mix a small amount of quick-setting hydraulic cement with water in a container per manufacturer's recommendation (leave cement thick so it can be molded). Apply the cement generously to the top of the port flange and hold the port onto the concrete/masonry surface at one end of the crack until it sticks when the hand is released (usually about 1 minute). Repeat until the entire crack is sealed and ported. **IMPORTANT:** Be sure not to cover the port opening/closing interface with the cement. If this interface is covered, the cement must be cut away from this interface with a utility knife once it is cured, otherwise, the port will not close.
2. To seal the remaining portions of the crack, mix small amounts of the hydraulic cement and apply it to the crack in a similar fashion. It is recommended that the paste-over be 3/8" thick and 1" wide. Once the entire crack is covered, all leaking water should be directed through the open ports. If water is leaking from any parts of the paste-over, be sure to patch these areas with additional hydraulic cement before injecting the crack.

Mildly Leaking Crack Application - Sealing of the crack and attachment of E-Z-Click™ drill-in injection ports (Model EIPX-EZ)

1. Using a hammer drill or roto-hammer, drill 5/8" holes 3/4" deep at each end of the crack and along the crack approximately 8" apart.
2. Using the E-Z-Click Drilled-In port (model EIPX-EZ), gently pound the port into the drilled hole at the top of a vertical crack or at either end of a horizontal crack. Mix a small amount of quick-setting hydraulic cement with water in a container per manufacturer's recommendation (leave cement thick so it can be molded).
3. Apply the cement generously to the top of the port flange and hold until it sticks when the hand is released (usually about 1 minute). Repeat until the entire crack is sealed and ported. **IMPORTANT:** Be sure not to cover the port opening/closing interface with the cement. If this interface is covered, the cement must be cut away from this interface with a utility knife once it is cured, otherwise, the port will not close.
4. To seal the remaining portions of the crack, mix small amounts of the hydraulic cement and apply it to the crack in a similar fashion. Starting at one end and working toward the other. In vertical applications start at the top and work down. It is recommended that the paste-over be at least 3/8" thick and 1" wide. Once the entire crack is covered, all leaking water should be directed through the open ports. If water is leaking from any parts of the paste-over, be sure to patch these areas with additional hydraulic cement before injecting the crack.

Injection Procedure for Crack-Pac® Flex-H₂O™ crack sealer

1. Follow cartridge preparation instructions on the cartridge label. Verify that the material flowing from the nozzle is a uniform green color.
2. Attach the E-Z-Click™ fitting to the end of the nozzle by pushing the tubing over the barbs at the end of the nozzle. Make sure that all ports are pushed in to the open position.
3. Attach the E-Z-Click™ injection fitting to the first E-Z-Click™ port until it clicks into place. Make sure that the head of the port is pushed in to the open position. In vertical applications, begin injection at the lowest port and work your way up. In a horizontal application start at one end of the crack and work your way to the other end.
4. Inject polyurethane into the first port until material shows at the next port. Remove the E-Z-Click fitting by bracing the base of the port and pulling out gently on the head of the port to close it. Pulling too hard may dislodge the port from the surface of the concrete, causing a leak. Depress the metal tab on the head of the E-Z-Click fitting and remove it from the port.
5. Move to the next port and repeat until all ports have been injected.

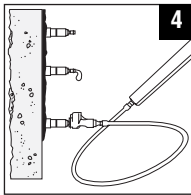
**Injection Tips**

- For narrow cracks it may be necessary to increase the pressure gradually until the polyurethane begins to flow. It may also be necessary to wait a few minutes for the material to fill the crack and travel to the next port.
- If desired, once the polyurethane has cured, remove the injection ports and paste-over epoxy or hydraulic cement. The paste-over can be removed with a chisel, scraper or grinder.

Troubleshooting***Polyurethane is flowing into the crack, but not showing up at the next port.***

This can indicate that either the crack expands and/or branches off under the surface of the concrete. Continue to inject and fill these voids.

Back pressure is preventing polyurethane from flowing.

This can indicate several situations:

- The crack is not continuous and the portion being injected is full.
- The port is not aligned over the crack properly.
- The crack is blocked by debris.

Polyurethane is leaking from the pasted-over crack or around injection ports.

Stop injecting. If using a fast cure paste-over material (ETR or CIP), wipe off the leaking injection epoxy with a cotton cloth and re-apply the paste over material. Wait a approximately 10–15 minutes to allow the paste-over to begin to harden. If the leak is large (e.g. the port broke off of the concrete surface) it is a good idea to wait approximately 30 minutes, or longer as necessary, to allow the paste-over to cure more completely. Check to see that the paste-over is hard before re-injecting or the paste-over or ports may leak.

Another option for small leaks is to clean off the injection adhesive and use paraffin or crayon to seal the holes.

More polyurethane is being used than estimated.

This may indicate that the crack either expands or branches off below the surface. Continue to inject and fill these voids.

Less polyurethane is being used than estimated.

This may indicate that the crack is shallower than originally thought, or the polyurethane is not penetrating the crack sufficiently before moving to the next port.

CRACK REPAIR ACCESSORIES

Crack Repair Accessories

EMN022 – Opti-Mix® Mixing Nozzle

The Opti-Mix® static mixing nozzle is specifically designed for crack injection epoxies and ensures thorough mixing of epoxy components:

- For use with both low-viscosity and gel-viscosity ETI formulations.
- Flow regulators ensure that resin and hardener flow at equal rates and prevent mixed epoxy from flowing back out of the nozzle into the cartridge. This ensures thorough mixing and prevents mixed product from curing in the neck of the cartridge, causing blockage. Testing shows that mixing with the Opti-Mix nozzle is 4 times more consistent than a standard spiral mixing nozzle.
- For use with pneumatic, battery and manual dispensing tools.
- Half the length of standard spiral mixing nozzles, allowing easy access in cramped conditions and reducing waste.
- Barbed end allows easy attachment to the E-Z-Click™ injection fitting.
- When dispensing low viscosity material, using a standard spiral mixing nozzle and a manual dispensing tool, resin and hardener surge unevenly through the nozzle without being thoroughly combined. The result is poorly mixed epoxy that will not fully cure and will not effectively repair the crack. The Opti-Mix nozzle corrects this problem utilizing unique mixing elements and a flow regulator that allows the use of a manual tool with low viscosity epoxy.

E-Z-Click™ Injection System

The E-Z-Click injection system is comprised of a specially designed fitting and ports that take the mess out of your repair project while allowing you to work faster. The E-Z-Click injection fitting installs onto the end of the Opti-Mix mixing nozzle and clicks onto the E-Z-Click™ ports during injection.

- Positive connection eliminates messy leakage, minimizing waste and clean-up.
- No drilling of ports: E-Z-Click ports perform while pasted to the surface of the concrete. No drilling required for most applications.
- Disconnect the fitting from the E-Z-Click port and the epoxy stops flowing, no leaky mess.
- After injecting, pull the head of the E-Z-Click port out to close it and prevent leakage.
- One person can work faster without having to hold the tube on the port.

ETR Epoxy Paste-Over

Ideal for pasting over the surface of cracks and attaching ports for pressure injection. The non-sag paste consistency enables paste-up on horizontal, vertical and overhead applications. Fast cure time means shorter time between paste-over and injection. Packaged as a kit in separate 8 oz. canisters which are mixed manually to yield 16 ounces of epoxy. Also ideal for small concrete repairs and miscellaneous patching. Each kit contains enough material to cover approximately 8 lineal feet of cracks.

CIP Paste-Over

CIP is a fast-curing, two-part epoxy paste-over material. It is used to seal cracks and to secure injection ports over concrete prior to epoxy or urethane foam injection repair. CIP sets up rigid and can either be left on the concrete or ground or chiseled off at the completion of a crack injection job.

CIP-F Paste-Over

CIP-F is a flexible, peelable and fast-curing polyurea paste-over material. It is used to temporarily seal cracks and to secure injection ports over concrete prior to epoxy or urethane foam injection repair. CIP-F can be peeled off at the completion of a crack injection job by pulling on starter tabs placed under the lead edge surface at the time of application or by prying under the paste-over.

Crack Repair Accessories Product Data

Description	Model No.	Pkg. Qty.	Ctn. Qty. (ea.)
6 Opti-Mix® mixing nozzles for ETI epoxies (6½' long, ¾" square). Includes retaining nuts. ¹	EMN022-RP6	6	30 (5 Packs)
100 E-Z-Click flush mount injection ports and 1 E-Z-Click injection fitting (compatible with all Simpson Strong-Tie paste-overs)	EIP-EZA	—	100
20 E-Z-Click flush mount injection ports	EIP-EZAKT	—	5 Kits
20 E-Z-Click corner mount/drilled-in injection ports ²	EIPX-EZ-RP20	20	100 (5 Packs)
20 E-Z-Click corner mount/drilled-in injection ports and 1 E-Z-Click injection fitting ²	EIPX-EZKT	—	5 Kits
E-Z-Click injection fitting	EIF-EZ	1	10
ETR Kit containing 1 8-oz. canister of resin and 1 8-oz. canister of hardener	ETR16	—	4 Kits

1. Use only an appropriate Simpson Strong-Tie® mixing nozzle in accordance with Simpson Strong-Tie instructions. Modification or improper use of mixing nozzle may impair epoxy performance.
2. EIPX intended for use as a surface mount port in corners and a drilled-in port on flat surfaces. All accessories compatible with ETI-LV and ETI-GV epoxies.

Crack Injection Paste-Over in Cartridge Delivery System

Model No.	Capacity (ounces (cubic inches))	Cartridge Type	Carton Quantity	Dispensing Tool(s)	Mixing Nozzle
CIP22	22 (39.7)	side-by-side	10	EDT22S EDTA22P EDTA22CKT	EMN22i
CIPF22	22 (39.7)	side-by-side	10	EDT22S EDTA22P EDTA22CKT	included

1. Use only appropriate Simpson Strong-Tie mixing nozzle in accordance with Simpson Strong-Tie instructions. Modification or improper use of mixing nozzle may impair paste over performance.
2. Each cartridge contains enough material to cover approximately 8 lineal feet of cracks.
3. CIPF22 can be dispensed without the mixing nozzle and mixed by hand using a mixing board and putty knife.



Opti-Mix®
Mixing Nozzle



E-Z-Click™ Ports and
Injection Fitting



E-Z-Click™
Injection Fitting



EIP-EZA
Flush Mount
Port



EIPX-EZ
Corner
Mount/
Drilled-In
Port



ETR16

Cure Schedule - ETR and CIP

Base Material Temperature	Cure Time	
	°F	°C
40	4	24 hrs.
60	16	2 hrs.
80	27	1 hr.
100	38	1 hr.



CIP



CIP-F

Cure Schedule - CIP-F

Base Material Temperature	Cure Time	
	°F	°C
40	4	3 hrs.
72	22	1 hr.

Detailed information on the full line of Simpson Strong-Tie® manual and pneumatic dispensing tools is available on pages 72–73.

Mechanical Anchors



Simpson Strong-Tie mechanical anchors are designed to install easily and securely into a variety of base materials, including concrete, grouted and hollow CMU and brick. Specifiers and contractors trust Simpson Strong-Tie[®] anchors for optimum performance under the most demanding structural applications.





Strong-Bolt® 2 Wedge Anchor for Cracked and Uncracked Concrete

The Strong-Bolt® 2 wedge anchor is the next-generation solution for cracked and uncracked concrete. Following rigorous testing according to ICC-ES acceptance criteria, the Strong-Bolt 2 anchor received classification as a Category 1 anchor, the highest attainable anchor category for performance in cracked concrete under static and seismic loading. Available in stainless steel, it is code-listed by ICC-ES under the 2009 IBC requirements for post-installed anchors in cracked and uncracked concrete.

FEATURES:

- **Category 1 anchor classification:** The Strong-Bolt 2 anchor received classification as a Category 1 anchor, which is established by performance in reliability tests in accordance with AC193 and ACI355.2 test criteria. Category 1 is the highest attainable anchor category for reliability.
- **Tri-segmented clip:** Each segment adjusts independently, increasing follow-up expansion should the hole increase in size as a result of a crack
- **Dual embossments on each clip segment:** Enables clip to undercut into the concrete thereby increasing follow-up expansion should a crack occur
- **The 3/8" anchor solution approved for 3 1/4" concrete thickness:** The Strong-Bolt 2 anchor can be installed in cracked concrete with a minimum thickness of 3 1/4", including concrete-over-metal decking
- **High-strength alloy clip on carbon-steel anchors:** This special alloy clip offers improved performance
- **Standard (ANSI) fractional anchor:** Fits most fixtures and installs with common drill bit sizes and tools
- **Type 316 stainless-steel clip on stainless steel anchors:** In addition to superior corrosion resistance, a stainless-steel clip offers "memory" that contributes to the anchor's performance if the hole increases in size because of a crack

MATERIAL: Carbon-steel stud with special alloy clip; stainless-steel stud with stainless-steel clip

FINISH: Zinc-plated (carbon steel)

CODES: ICC-ES ESR-3037 (carbon and stainless steel in concrete); IAPMO ES ER-240 (carbon steel in CMU); City of Los Angeles RR25891; Underwriters Laboratories File Ex3605; Factory Mutual 3043442; Florida – Pending

TEST CRITERIA: The Strong-Bolt 2 wedge anchor has been tested in accordance with the ICC-ES Acceptance Criteria for Mechanical Anchors in Concrete Elements (AC 193) and ACI 355.2 for the following:

- Static tension and shear loading in cracked and uncracked concrete
- Seismic and wind loading in cracked and uncracked concrete
- Performance in cracked concrete
- Performance in lightweight concrete over metal deck

INSTALLATION: • Do not use an impact wrench to set or tighten the Strong-Bolt 2 anchor.

Caution: Oversized holes in the base material will make it difficult to set the anchor and will reduce the anchor's load capacity.

- Drill a hole in the base material using a carbide drill bit the same diameter as the nominal diameter of the anchor to be installed. Drill the hole to the specified embedment depth and blow it clean using compressed air. Overhead installations need not be blown clean. Alternatively, drill the hole deep enough to accommodate minimum hole depth and dust from drilling.
- Assemble the anchor with nut and washer so that the top of the nut is flush with the top of the anchor. Place the anchor in the fixture and drive into the hole until washer and nut are tight against the fixture.
- Tighten to the required installation torque.

DESIGN EXAMPLE: See pages 233–234



Strong-Bolt® 2 Wedge Anchor

Installation Sequence

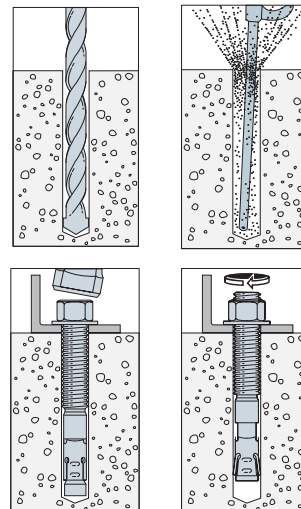

Length Identification Head Marks on Strong-Bolt® 2 Wedge Anchors (corresponds to length of anchor – inches)

Mark	Units	A	B	C	D	E	F	G	H	I	J	K	L	M	N	O	P	Q	R	S	T	U	V	W	X	Y	Z
From	in.	1 1/2	2	2 1/2	3	3 1/2	4	4 1/2	5	5 1/2	6	6 1/2	7	7 1/2	8	8 1/2	9	9 1/2	10	11	12	13	14	15	16	17	18
Up To But Not Including	in.	2	2 1/2	3	3 1/2	4	4 1/2	5	5 1/2	6	6 1/2	7	7 1/2	8	8 1/2	9	9 1/2	10	11	12	13	14	15	16	17	18	19

Strong-Bolt® 2 Wedge Anchor Product Information

Strong-Bolt® 2 Anchor Product Data

Size (in.)	Carbon Steel Model No.	316 Stainless Steel Model No.	Drill Bit Dia. (in.)	Thread Length (in.)	Quantity	
					Box	Carton
5/8 x 2 3/4	STB2-37234	STB2-372346SS	5/8	1 5/16	50	250
5/8 x 3	STB2-37300	STB2-373006SS	5/8	1 5/16	50	250
5/8 x 3 1/2	STB2-37312	STB2-373126SS	5/8	2 1/16	50	250
5/8 x 3 3/4	STB2-37334	STB2-373346SS	5/8	2 5/16	50	250
5/8 x 5	STB2-37500	STB2-375006SS	5/8	3 5/16	50	200
5/8 x 7	STB2-37700	STB2-377006SS	5/8	5 5/16	50	200
1/2 x 3 3/4	STB2-50334	STB2-503346SS	1/2	2 1/16	25	125
1/2 x 4 1/4	STB2-50414	STB2-504146SS	1/2	2 9/16	25	100
1/2 x 4 3/4	STB2-50434	STB2-504346SS	1/2	3 1/16	25	100
1/2 x 5 1/2	STB2-50512	STB2-505126SS	1/2	3 13/16	25	100
1/2 x 7	STB2-50700	STB2-507006SS	1/2	5 5/16	25	100
1/2 x 8 1/2	STB2-50812	STB2-508126SS	1/2	6	25	50
1/2 x 10	STB2-50100	STB2-501006SS	1/2	6	25	50
5/8 x 4 1/2	STB2-62412	STB2-624126SS	5/8	2 7/16	20	80
5/8 x 5	STB2-62500	STB2-625006SS	5/8	2 15/16	20	80
5/8 x 6	STB2-62600	STB2-626006SS	5/8	3 15/16	20	80
5/8 x 7	STB2-62700	STB2-627006SS	5/8	4 15/16	20	80
5/8 x 8 1/2	STB2-62812	STB2-628126SS	5/8	6	20	40
5/8 x 10	STB2-62100	STB2-621006SS	5/8	6	10	20
3/4 x 5 1/2	STB2-75512	STB2-755126SS	3/4	3 3/16	10	40
3/4 x 6 1/4	STB2-75614	STB2-756146SS	3/4	3 15/16	10	40
3/4 x 7	STB2-75700	STB2-757006SS	3/4	4 11/16	10	40
3/4 x 8 1/2	STB2-75812	STB2-758126SS	3/4	6	10	20
3/4 x 10	STB2-75100	STB2-751006SS	3/4	6	10	20

Material Specifications

Carbon Steel - Zinc Plated ¹			
Component Materials			
Anchor Body	Nut	Washer	Clip
Carbon Steel	Carbon Steel ASTM A 563, Grade A	Carbon Steel ASTM F844	Carbon Steel ASTM A 568

1. Zinc meets ASTM B 633, Class SC 1 (Fe / Zn 5), Type III.

Stainless Steel			
Component Materials			
Anchor Body	Nut	Washer	Clip
Type 316 Stainless Steel	Type 316 Stainless Steel	Type 316 Stainless Steel	Type 316 Stainless Steel

Carbon Steel Strong-Bolt® 2 Wedge Anchor Installation Information¹

Characteristic	Symbol	Units	Nominal Anchor Diameter								
			Carbon Steel								
			3/8 inch		1/2 inch		5/8 inch		3/4 inch		
Installation Information											
Nominal Diameter	d_a^3	in.	3/8		1/2		5/8		3/4		
Drill Bit Diameter	d	in.	3/8		1/2		5/8		3/4		
Baseplate Clearance Hole Diameter ²	d_c	in.	7/16		9/16		1 1/16		7/8		
Installation Torque	T_{inst}	ft-lbf	30		60		90		150		
Nominal Embedment Depth	h_{nom}	in.	1 1/8	2 7/8	2 3/4	3 3/8	3 3/8	5 1/8	4 1/8	5 3/4	
Effective Embedment Depth	h_{ef}	in.	1 1/2	2 1/2	2 1/4	3 3/8	2 3/4	4 1/2	3 3/8	5	
Minimum Hole Depth	h_{hole}	in.	2	3	3	4 1/8	3 5/8	5 3/8	4 3/8	6	
Minimum Overall Anchor Length	ℓ_{anch}	in.	2 3/4	3 1/2	3 3/4	5 1/2	4 1/2	6	5 1/2	7	
Critical Edge Distance	c_{ac}	in.	6 1/2	6	6 1/2	6 1/2	7 1/2	7 1/2	9	8	
Minimum Edge Distance	c_{min}	in.	6		7		4		6 1/2		
	for $s \geq$	in.	—		—		—		8		
Minimum Spacing	s_{min}	in.	3		7		4		5		
	for $c \geq$	in.	—		—		—		8		
Minimum Concrete Thickness	h_{min}	in.	3 1/4	4 1/2	4 1/2	5 1/2	6	5 1/2	7 7/8	6 3/4	
Additional Data											
Yield Strength	f_{ya}	psi	92,000				85,000				70,000
Tensile Strength	f_{uta}^4	psi	—				115,000				110,000
Minimum Tensile and Shear Stress Area	A_{se}	in ²	0.0514		0.105		0.166		0.270		
Axial Stiffness in Service Load Range - Cracked and Uncracked Concrete	β	lb./in	34,820		63,570		91,370		118,840		

1. The information presented in this table is to be used in conjunction with the design criteria of ACI 318 Appendix D.

2. The clearance must comply with applicable code requirements for the connected element.

3. For the 2006 IBC, d_o replaces d_a .

4. For the 2003 IBC, f_{ut} replaces f_{uta} .

Strong-Bolt® 2 Wedge Anchor Product Information

Stainless-Steel Strong-Bolt® 2 Wedge Anchor Installation Information¹

Characteristic	Symbol	Units	Nominal Anchor Diameter							
			Stainless Steel							
			3/8 inch		1/2 inch		5/8 inch		3/4 inch	
Installation Information										
Nominal Diameter	d_a^3	in.	3/8		1/2		5/8		3/4	
Drill Bit Diameter	d	in.	3/8		1/2		5/8		3/4	
Baseplate Clearance Hole Diameter ²	d_c	in.	7/16		9/16		11/16		7/8	
Installation Torque	T_{inst}	ft-lbf	30		60		80		150	
Nominal Embedment Depth	h_{nom}	in.	1 7/8	2 7/8	2 3/4	3 7/8	3 3/8	5 1/8	4 1/8	5 3/4
Effective Embedment Depth	h_{ef}	in.	1 1/2	2 1/2	2 1/4	3 3/8	2 3/4	4 1/2	3 3/8	5
Minimum Hole Depth	h_{hole}	in.	2	3	3	4 1/8	3 5/8	5 5/8	4 3/8	6
Minimum Overall Anchor Length	ℓ_{anch}	in.	2 3/4	3 1/2	3 3/4	5 1/2	4 1/2	6	5 1/2	7
Critical Edge Distance	c_{ac}	in.	6 1/2	8 1/2	4 1/2	7	7 1/2	9	8	8
Minimum Edge Distance	c_{min}	in.	6		6 1/2	5	4	4		6
	for $s \geq$	in.	10		—	—	8	8		—
Minimum Spacing	s_{min}	in.	3		8	5 1/2	4	6 1/4		6 1/2
	for $c \geq$	in.	10		—	—	8	5 1/2		—
Minimum Concrete Thickness	h_{min}	in.	3 1/4	4 1/2	4 1/2	6	5 1/2	7 7/8	6 3/4	8 3/4
Additional Data										
Yield Strength	f_{ya}	psi	80,000		92,000		82,000		68,000	
Tensile Strength	f_{uta}^4	psi	100,000		115,000		108,000		95,000	
Minimum Tensile and Shear Stress Area	A_{se}	in ²	0.0514		0.105		0.166		0.270	
Axial Stiffness in Service Load Range - Cracked and Uncracked Concrete	β	lb./in	29,150		54,900		61,270		154,290	

1. The information presented in this table is to be used in conjunction with the design criteria of ACI 318 Appendix D.
2. The clearance must comply with applicable code requirements for the connected element.
3. For the 2006 IBC, d_o replaces d_a .
4. For the 2003 IBC, f_{ut} replaces f_{uta} .

Strong-Bolt® 2 Wedge Anchor Performance Data



See page 13 for an explanation of the load table icons

Carbon Steel Strong-Bolt® 2 Wedge Anchor Tension Strength Design Data¹

Characteristic	Symbol	Units	Nominal Anchor Diameter							
			Carbon Steel							
			¾ inch		½ inch		¾ inch		¾ inch	
Anchor Category	1,2 or 3	—	1							
Nominal Embedment Depth	h_{nom}	in.	1¾	2¾	2¾	3¾	3¾	5¾	4¾	5¾
Steel Strength in Tension (ACI 318 Section D.5.1)										
Steel Strength in Tension	N_{sa}	lb	5,600		12,100		19,070		29,700	
Strength Reduction Factor - Steel Failure ²	ϕ_{sa}	—	0.75							
Concrete Breakout Strength in Tension (ACI 318 Section D.5.2)⁸										
Effective Embedment Depth	h_{ef}	in.	1½	2½	2¾	3¾	2¾	4½	3¾	5
Critical Edge Distance	c_{ac}	in.	6½	6	6½	7½	7½	9	9	8
Effectiveness Factor - Uncracked Concrete	k_{uncr}	—	24		24		24		24	
Effectiveness Factor - Cracked Concrete	k_{cr}	—	17		17		17		17	
Modification Factor	$\Psi_{c,N}$	—	1.00		1.00		1.00		1.00	
Strength Reduction Factor - Concrete Breakout Failure ³	ϕ_{cb}	—	0.65							
Pull-Out Strength in Tension (ACI 318 Section D.5.3)⁸										
Pull-Out Strength Cracked Concrete ($f'_c = 2500$ psi)	$N_{p,cr}$	lb	1,300 ⁵	2,775 ⁵	N/A ⁴	3,735 ⁵	N/A ⁴	6,895 ⁵	N/A ⁴	8,500 ⁵
Pull-Out Strength Uncracked Concrete ($f'_c = 2500$ psi)	$N_{p,uncr}$	lb	N/A ⁴	3,340 ⁵	3,615 ⁵	5,255 ⁵	N/A ⁴	9,025 ⁵	7,115 ⁵	8,870 ⁵
Strength Reduction Factor - Pullout Failure ⁶	ϕ_p	—	0.65							
Tensile Strength for Seismic Applications (ACI Section D.3.3.3)⁸										
Tension Strength of Single Anchor for Seismic Loads ($f'_c = 2500$ psi)	$N_{p,eq}$	lb	1,300 ⁵	2,775 ⁵	N/A ⁴	3,735 ⁵	N/A ⁴	6,895 ⁵	N/A ⁴	8,500 ⁵
Strength Reduction Factor - Pullout Failure ⁶	ϕ_{eq}	—	0.65							

- The information presented in this table must be used in conjunction with the design criteria of ACI 318 Appendix D, except as modified below.
- The tabulated value of ϕ_{sa} applies when the load combinations of Section 1605.2.1 of the IBC, or ACI 318 Section 9.2 are used. If the load combinations of ACI 318 Appendix C are used, the appropriate value of ϕ_{sa} must be determined in accordance with ACI 318 D.4.5. Strong-Bolt® 2 anchors are ductile steel elements as defined in ACI 318 D.1.
- The tabulated value of ϕ_{cb} applies when both the load combinations of Section 1605.2.1 of the IBC, or ACI 318 Section 9.2 are used and the requirements of ACI 318 Section D.4.4(c) for Condition B are met. Condition B applies where supplementary reinforcement is not provided. For installations where complying supplementary reinforcement can be verified, the ϕ_{cb} factors described in ACI 318 D.4.4 for Condition A are allowed. If the load combinations of ACI 318 Section 9.2 are used and the requirements of ACI 318 Section D.4.4 for Condition A are met, the appropriate value of ϕ_{cb} must be determined in accordance with ACI 318 D.4.4(c). If the load combinations of ACI 318 Appendix C are used, the appropriate value of ϕ_{cb} must be determined in accordance with ACI 318 D.4.5(c).
- N/A (Not Applicable) denotes that pullout resistance does not need to be considered.
- The characteristic pull-out strength for greater concrete compressive strengths shall be increased by multiplying the tabular value by $(f'_c / 2,500 \text{ psi})^{0.5}$.
- The tabulated value of ϕ_p or ϕ_{eq} applies when the load combinations of Section 1605.2.1 of the IBC, or ACI 318 Section 9.2 are used and the requirements of ACI 318 D.4.4(c) for Condition B are met. If the load combinations of ACI 318 Appendix C are used, appropriate value of ϕ must be determined in accordance with ACI 318 Section D.4.5(c).
- For the 2003 IBC, Ψ_3 replaces $\Psi_{c,N}$.
- For sand-lightweight concrete, in lieu of ACI 318 Section D.3.4, modify the value of concrete breakout strength, $N_{p,cr}$, $N_{p,uncr}$ and N_{eq} by 0.6. All-lightweight concrete is beyond the scope of this table.

Strong-Bolt® 2 Wedge Anchor Performance Data

Stainless Steel Strong-Bolt® 2 Wedge Anchor Tension Strength Design Data¹

* See page 13 for an explanation of the load table icons

Characteristic	Symbol	Units	Nominal Anchor Diameter							
			Stainless Steel							
			½ inch	¾ inch	1 inch	1 ¼ inch	1 ½ inch	2 inch	2 ½ inch	3 inch
Anchor Category	1,2 or 3	—	1							
Nominal Embedment Depth	h_{nom}	in.	1 ¾	2 ¾	2 ¾	3 ¾	3 ¾	5 ¾	4 ¾	5 ¾
Steel Strength in Tension (ACI 318 Section D.5.1)										
Steel Strength in Tension	N_{sa}	lb	5,140		12,075		17,930		25,650	
Strength Reduction Factor - Steel Failure ²	ϕ_{sa}	—	0.75							
Concrete Breakout Strength in Tension (ACI 318 Section D.5.2)¹⁰										
Effective Embedment Depth	h_{ef}	in.	1 ½	2 ½	2 ¾	3 ¾	2 ¾	4 ½	3 ¾	5
Critical Edge Distance	c_{ac}	in.	6 ½	8 ½	4 ½	7	7 ½	9	8	8
Effectiveness Factor - Uncracked Concrete	k_{un-cr}	—	24		24		24		24	
Effectiveness Factor - Cracked Concrete	k_{cr}	—	17		17		17		17	
Modification Factor	$\psi_{c,N}$	—	1.00		1.00		1.00		1.00	
Strength Reduction Factor - Concrete Breakout Failure ³	ϕ_{cb}	—	0.65							
Pull-Out Strength in Tension (ACI 318 Section D.5.3)¹⁰										
Pull-Out Strength Cracked Concrete ($f'_c = 2500$ psi)	$N_{p,cr}$	lb	1,720 ⁶	3,145 ⁶	2,560 ⁵	4,305 ⁵	N/A ⁴	6,545 ⁷	N/A ⁴	8,230 ⁵
Pull-Out Strength Uncracked Concrete ($f'_c = 2500$ psi)	$N_{p,un-cr}$	lb	N/A ⁴	4,770 ⁶	3,230 ⁵	4,495 ⁵	N/A ⁴	7,615 ⁵	7,725 ⁷	9,625 ⁷
Strength Reduction Factor - Pullout Failure ⁸	ϕ_p	—	0.65							
Tensile Strength for Seismic Applications (ACI Section D.3.3.3)¹⁰										
Tension Strength of Single Anchor for Seismic Loads ($f'_c = 2500$ psi)	$N_{p,eq}$	lb	1,720 ⁶	2,830 ⁶	2,560 ⁵	4,305 ⁵	N/A ⁴	6,545 ⁷	N/A ⁴	8,230 ⁵
Strength Reduction Factor - Pullout Failure ⁸	ϕ_{eq}	—	0.65							

- The information presented in this table must be used in conjunction with the design criteria of ACI 318 Appendix D, except as modified below.
- The tabulated value of ϕ_{sa} applies when the load combinations of Section 1605.2.1 of the IBC, or ACI 318 Section 9.2 are used. If the load combinations of ACI 318 Appendix C are used, the appropriate value of ϕ_{sa} must be determined in accordance with ACI 318 D.4.5. Strong-Bolt® 2 anchors are ductile steel elements as defined in ACI 318 D.1.
- The tabulated value of ϕ_{cb} applies when both the load combinations of Section 1605.2.1 of the IBC, or ACI 318 Section 9.2 are used and the requirements of ACI 318 Section D.4.4(c) for Condition B are met. Condition B applies where supplementary reinforcement is not provided. For installations where complying supplementary reinforcement can be verified, the ϕ_{cb} factors described in ACI 318 D.4.4 for Condition A are allowed. If the load combinations of ACI 318 Section 9.2 are used and the requirements of ACI 318 Section D.4.4 for Condition A are met, the appropriate value of ϕ_{cb} must be determined in accordance with ACI 318 D.4.4(c). If the load combinations of ACI 318 Appendix C are used, the appropriate value of ϕ_{cb} must be determined in accordance with ACI 318 D.4.5(c).
- N/A (Not Applicable) denotes that pullout resistance does not need to be considered.
- The characteristic pull-out strength for greater concrete compressive strengths shall be increased by multiplying the tabular value by $(f'_c / 2,500 \text{ psi})^{0.5}$.
- The characteristic pull-out strength for greater concrete compressive strengths shall be increased by multiplying the tabular value by $(f'_c / 2,500 \text{ psi})^{0.3}$.
- The characteristic pull-out strength for greater concrete compressive strengths shall be increased by multiplying the tabular value by $(f'_c / 2,500 \text{ psi})^{0.4}$.
- The tabulated value of ϕ_p or ϕ_{eq} applies when the load combinations of Section 1605.2.1 of the IBC, or ACI 318 Section 9.2 are used and the requirements of ACI 318 D.4.4(c) for Condition B are met. If the load combinations of ACI 318 Appendix C are used, appropriate value of ϕ must be determined in accordance with ACI 318 Section D.4.5(c).
- For the 2003 IBC, ψ_3 replaces $\psi_{c,N}$.
- For sand-lightweight concrete, in lieu of ACI 318 Section D.3.4, modify the value of concrete breakout strength, $N_{p,cr}$, $N_{p,un-cr}$ and N_{eq} by 0.6. All-lightweight concrete is beyond the scope of this table.

Strong-Bolt® 2 Wedge Anchor Performance Data

Carbon Steel Strong-Bolt® 2 Wedge Anchor Shear Strength Design Data¹

* See page 13 for an explanation of the load table icons

Characteristic	Symbol	Units	Nominal Anchor Diameter							
			Carbon Steel							
			% inch		½ inch		% inch		% inch	
Anchor Category	1, 2 or 3	—	1							
Nominal Embedment Depth	h_{nom}	in.	1%	2%	2%	3%	3%	5%	4%	5%
Steel Strength in Shear (ACI 318 Section D.6.1)										
Steel Strength in Shear	V_{sa}	lb	1,800		7,235		11,035		14,480	
Strength Reduction Factor - Steel Failure ²	ϕ_{sa}	—	0.65							
Concrete Breakout Strength in Shear (ACI 318 Section D.6.2)⁶										
Outside Diameter	d_a^5	in.	0.375		0.500		0.625		0.750	
Load Bearing Length of Anchor in Shear	ℓ_e	in.	1.500	2.500	2.250	3.375	2.750	4.500	3.375	5.000
Strength Reduction Factor - Concrete Breakout Failure ³	ϕ_{cb}	—	0.70							
Concrete Pryout Strength in Shear (ACI 318 Section D.6.3)										
Coefficient for Pryout Strength	k_{cp}	—	1.0	2.0	1.0	2.0	2.0		2.0	
Effective Embedment Depth	h_{ef}	in.	1 ½	2 ½	2 ¼	3 %	2 %	4 ½	3 %	5
Strength Reduction Factor - Concrete Pryout Failure ⁴	ϕ_{cp}	—	0.70							
Steel Strength in Shear for Seismic Applications (ACI 318 Section D.3.3.3)										
Shear Strength of Single Anchor for Seismic Loads ($f'_c = 2500$ psi)	$V_{sa,eq}$	lb	1,800		6,510		9,930		11,775	
Strength Reduction Factor - Steel Failure ²	ϕ_{sa}	—	0.65							

- The information presented in this table must be used in conjunction with the design criteria of ACI 318 Appendix D, except as modified below.
- The tabulated value of ϕ_{sa} applies when the load combinations of Section 1605.2.1 of the IBC, or ACI 318 Section 9.2 are used and the requirements of ACI 318 D.4.4(c) for Condition B are met. If the load combinations of ACI 318 Appendix C are used, the appropriate value of ϕ_{sa} must be determined in accordance with ACI 318 D.4.5. Strong-Bolt® 2 anchors are ductile steel elements as defined in ACI 318 D.1.
- The tabulated value of ϕ_{cb} applies when both the load combinations of Section 1605.2.1 of the IBC, or ACI 318 Section 9.2 are used and the requirements of ACI 318 Section D.4.4(c) for Condition B are met. Condition B applies where supplementary reinforcement is not provided. For installations where complying supplementary reinforcement can be verified, the ϕ_{cb} factors described in ACI 318 Section D.4.4 for Condition A are allowed. If the load combinations of ACI 318 Section 9.2 are used and the requirements of ACI 318 Section D.4.4 for Condition A are met, the appropriate value of ϕ_{cb} must be determined in accordance with ACI 318 Section D.4.4(c). If the load combinations of ACI 318 Appendix C are used, the appropriate value of ϕ_{cb} must be determined in accordance with ACI 318 Section D.4.5(c).
- The tabulated value of ϕ_{cp} applies when both the load combinations of ACI 318 Section 9.2 are used and the requirements of ACI 318 D.4.4(c) for Condition B are met. If the load combinations of ACI 318 Appendix C are used, the appropriate value of ϕ_{cp} must be determined in accordance with ACI 318 D.4.5(c).
- For the 2006 IBC, d_o replaces d_a .
- For sand-lightweight concrete, in lieu of ACI 318 Section D.3.4, modify the value of concrete breakout strength by 0.6. All-lightweight concrete is beyond the scope of this table.

Strong-Bolt® 2 Wedge Anchor Performance Data



* See page 13 for an explanation of the load table icons

Stainless-Steel Strong-Bolt® 2 Wedge Anchor Shear Strength Design Data¹

Characteristic	Symbol	Units	Nominal Anchor Diameter							
			Stainless Steel							
			¾ inch		½ inch		¾ inch		¾ inch	
Anchor Category	1,2 or 3	—	1							
Nominal Embedment Depth	h_{nom}	in.	1⅞	2⅞	2¾	3⅞	3¾	5⅞	4⅞	5¾
Steel Strength in Shear (ACI 318 Section D.6.1)										
Steel Strength in Shear	V_{sa}	lb	3,085		7,245		6,745	10,760	15,045	
Strength Reduction Factor - Steel Failure ²	ϕ_{sa}	—	0.65							
Concrete Breakout Strength in Shear (ACI 318 Section D.6.2)⁶										
Outside Diameter	d_a^5	in.	0.375		0.500		0.625		0.750	
Load Bearing Length of Anchor in Shear	ℓ_e	in.	1.500	2.500	2.250	3.375	2.750	4.500	3.375	5.000
Strength Reduction Factor - Concrete Breakout Failure ³	ϕ_{cb}	—	0.70							
Concrete Pryout Strength in Shear (ACI 318 Section D.6.3)										
Coefficient for Pryout Strength	k_{cp}	—	1.0	2.0	1.0	2.0	2.0		2.0	
Effective Embedment Depth	h_{ef}	in.	1½	2½	2¼	3¾	2¾	4½	3¾	5
Strength Reduction Factor - Concrete Pryout Failure ⁴	ϕ_{cp}	—	0.70							
Steel Strength in Shear for Seismic Applications (ACI 318 Section D.3.3.3)										
Shear Strength of Single Anchor for Seismic Loads ($f'_c = 2500$ psi)	$V_{sa,eq}$	lb	3,085		6,100		6,745	10,760	13,620	
Strength Reduction Factor - Steel Failure ²	ϕ_{sa}	—	0.65							

- The information presented in this table must be used in conjunction with the design criteria of ACI 318 Appendix D, except as modified below.
- The tabulated value of ϕ_{sa} applies when the load combinations of Section 1605.2.1 of the IBC, or ACI 318 Section 9.2 are used and the requirements of ACI 318 D.4.4(c) for Condition B are met. If the load combinations of ACI 318 Appendix C are used, the appropriate value of ϕ_{sa} must be determined in accordance with ACI 318 D.4.5. Strong-Bolt® 2 anchors are ductile steel elements as defined in ACI 318 D.1.
- The tabulated value of ϕ_{cb} applies when both the load combinations of Section 1605.2.1 of the IBC, or ACI 318 Section 9.2 are used and the requirements of ACI 318 Section D.4.4(c) for Condition B are met. Condition B applies where supplementary reinforcement is not provided. For installations where complying supplementary reinforcement can be verified, the ϕ_{cb} factors described in ACI 318 Section D.4.4 for Condition A are allowed. If the load combinations of ACI 318 Section 9.2 are used and the requirements of ACI 318 Section D.4.4 for Condition A are met, the appropriate value of ϕ_{cb} must be determined in accordance with ACI 318 Section D.4.4(c). If the load combinations of ACI 318 Appendix C are used, the appropriate value of ϕ_{cb} must be determined in accordance with ACI 318 Section D.4.5(c).
- The tabulated value of ϕ_{cp} applies when both the load combinations of ACI 318 Section 9.2 are used and the requirements of ACI 318 D.4.4(c) for Condition B are met. If the load combinations of ACI 318 Appendix C are used, the appropriate value of ϕ_{cp} must be determined in accordance with ACI 318 D.4.5(c).
- For the 2006 IBC, d_o replaces d_a .
- For sand-lightweight concrete, in lieu of ACI 318 Section D.3.4, modify the value of concrete breakout strength by 0.6. All-lightweight concrete is beyond the scope of this table.

Strong-Bolt® 2 Wedge Anchor Performance Data

Carbon Steel Strong-Bolt® 2 Wedge Anchor Tension and Shear Strength Design Data for the Soffit of Concrete Over Profile Steel Deck Floor and Roof Assemblies^{1,2,6,8,9}



* See page 13 for an explanation of the load table icons

Characteristic	Symbol	Units	Nominal Anchor Diameter								
			Carbon Steel								
			Lower Flute				Upper Flute				
			¾ inch		½ inch		¾ inch		¼ inch		¾ inch
Nominal Embedment Depth	h_{nom}	in.	2	3 ¾	2 ¾	4 ½	3 ¾	5 ¾	4 ½	2	2 ¾
Effective Embedment Depth	h_{ef}	in.	1 ¾	3	2 ¼	4	2 ¾	5	3 ¾	1 ¾	2 ¼
Installation Torque	T_{inst}	ft-lbf	30		60		90		150	30	60
Pullout Strength, concrete on metal deck (cracked) ^{3,4}	$N_{p,deck,cr}$	lb	1,040 ⁷	2,615 ⁷	2,040 ⁷	2,730 ⁷	2,615 ⁷	4,990 ⁷	2,815 ⁷	1,340 ⁷	3,785 ⁷
Pullout Strength, concrete on metal deck (uncracked) ^{3,4}	$N_{p,deck,uncr}$	lb	1,765 ⁷	3,150 ⁷	2,580 ⁷	3,840 ⁷	3,685 ⁷	6,565 ⁷	3,800 ⁷	2,275 ⁷	4,795 ⁷
Pullout Strength, concrete on metal deck (seismic) ^{3,4}	$N_{p,deck,eq}$	lb	1,040 ⁷	2,615 ⁷	2,040 ⁷	2,730 ⁷	2,615 ⁷	4,990 ⁷	2,815 ⁷	1,340 ⁷	3,785 ⁷
Steel Strength in Shear, concrete on metal deck ⁵	$V_{sa,deck}$	lb	1,595	3,490	2,135	4,580	2,640	7,000	4,535	3,545	5,920
Steel Strength in Shear, concrete on metal deck (seismic) ⁵	$V_{sa,deck,eq}$	lb	1,595	3,490	1,920	4,120	2,375	6,300	3,690	3,545	5,330

- The information presented in this table must be used in conjunction with the design criteria of ACI 318 Appendix D, except as modified below.
- Profile steel deck must comply with the configuration in the figure below, and have a minimum base-steel thickness of 0.035 inch [20 gauge]. Steel must comply with ASTM A 653/A 653M SS Grade 33 with minimum yield strength of 33,000 psi. Concrete compressive strength shall be 3,000 psi minimum.
- For anchors installed in the soffit of sand-lightweight or normal-weight concrete over metal deck floor and roof assemblies, calculation of the concrete breakout strength may be omitted.
- In accordance with ACI 318 Section D.5.3.2, the nominal pullout strength in cracked concrete for anchors installed in the soffit of sand-lightweight or normal-weight concrete over metal deck floor and roof assemblies $N_{p,deck,cr}$ shall be substituted for $N_{p,cr}$. Where analysis indicates no cracking at service loads, the normal pullout strength in uncracked concrete $N_{p,deck,uncr}$ shall be substituted for $N_{p,uncr}$. For seismic loads, $N_{p,deck,eq}$ shall be substituted for $N_{p,uncr}$.
- In accordance with ACI 318 Section D.6.1.2(c), the shear strength for anchors installed in the soffit of sand-lightweight or normal-weight concrete over metal deck floor and roof assemblies $V_{sa,deck}$ shall be substituted for V_{sa} . For seismic loads, $V_{sa,deck,eq}$ shall be substituted for V_{sa} .
- The minimum anchor spacing along the flute must be the greater of $3.0h_{ef}$ or 1.5 times the flute width.
- The characteristic pull-out strength for greater concrete compressive strengths shall be increased by multiplying the tabular value by $(f'_c / 3,000 \text{ psi})^{0.5}$.
- Concrete shall be normal-weight or structural sand-lightweight concrete having a minimum specified compressive strength, f'_c , of 3,000 psi.
- Minimum distance to edge of panel is $2h_{ef}$.

Stainless Steel Strong-Bolt® 2 Wedge Anchor Tension and Shear Strength Design Data for the Soffit of Concrete Over Profile Steel Deck Floor and Roof Assemblies^{1,2,6,10,11}



* See page 13 for an explanation of the load table icons

Characteristic	Symbol	Units	Stainless Steel											
			Lower Flute								Upper Flute			
			¾ inch		½ inch		¾ inch		¼ inch		¾ inch		½ inch	
			¾ inch		½ inch		¾ inch		¼ inch		¾ inch		½ inch	
Nominal Embedment Depth	h_{nom}	in.	2	3 ¾	2 ¾	4 ½	3 ¾	5 ¾	4 ½	2	2 ¾			
Effective Embedment Depth	h_{ef}	in.	1 ¾	3	2 ¼	4	2 ¾	5	3 ¾	1 ¾	2 ¼			
Installation Torque	T_{inst}	ft-lbf	30		60		80		150	30	60			
Pullout Strength, concrete on metal deck (cracked) ³	$N_{p,deck,cr}$	lb	1,230 ⁸	2,605 ⁸	1,990 ⁷	2,550 ⁷	1,750 ⁹	4,020 ⁹	3,030 ⁷	1,550 ⁸	2,055 ⁷			
Pullout Strength, concrete on metal deck (uncracked) ³	$N_{p,deck,uncr}$	lb	1,580 ⁸	3,950 ⁸	2,475 ⁷	2,660 ⁷	2,470 ⁷	5,000 ⁷	4,275 ⁹	1,990 ⁸	2,560 ⁷			
Pullout Strength, concrete on metal deck (seismic) ⁵	$N_{p,deck,eq}$	lb	1,230 ⁸	2,345 ⁸	1,990 ⁷	2,550 ⁷	1,750 ⁹	4,020 ⁹	3,030 ⁷	1,550 ⁸	2,055 ⁷			
Steel Strength in Shear, concrete on metal deck ⁴	$V_{sa,deck}$	lb	2,285	3,085	3,430	4,680	3,235	5,430	6,135	3,085	5,955			
Steel Strength in Shear, concrete on metal deck (seismic) ⁵	$V_{sa,deck,eq}$	lb	2,285	3,085	2,400	3,275	3,235	5,430	5,520	3,085	4,170			

- The information presented in this table must be used in conjunction with the design criteria of ACI 318 Appendix D, except as modified below.
- Profile steel deck must comply with the configuration in the figure below, and have a minimum base-steel thickness of 0.035 inch [20 gauge]. Steel must comply with ASTM A 653/A 653M SS Grade 33 with minimum yield strength of 33,000 psi. Concrete compressive strength shall be 3,000 psi minimum.
- For anchors installed in the soffit of sand-lightweight or normal-weight concrete over metal deck floor and roof assemblies, calculation of the concrete breakout strength may be omitted.
- In accordance with ACI 318 Section D.5.3.2, the nominal pullout strength in cracked concrete for anchors installed in the soffit of sand-lightweight or normal-weight concrete over metal deck floor and roof assemblies $N_{p,deck,cr}$ shall be substituted for $N_{p,cr}$. Where analysis indicates no cracking at service loads, the normal pullout strength in uncracked concrete $N_{p,deck,uncr}$ shall be substituted for $N_{p,uncr}$. For seismic loads, $N_{p,deck,eq}$ shall be substituted for $N_{p,uncr}$.
- In accordance with ACI 318 Section D.6.1.2(c), the shear strength for anchors installed in the soffit of sand-lightweight or normal-weight concrete over metal deck floor and roof assemblies $V_{sa,deck}$ shall be substituted for V_{sa} . For seismic loads, $V_{sa,deck,eq}$ shall be substituted for V_{sa} .
- The minimum anchor spacing along the flute must be the greater of $3.0h_{ef}$ or 1.5 times the flute width.
- The characteristic pull-out strength for greater concrete compressive strengths shall be increased by multiplying the tabular value by $(f'_c / 3,000 \text{ psi})^{0.5}$.
- The characteristic pull-out strength for greater concrete compressive strengths shall be increased by multiplying the tabular value by $(f'_c / 3,000 \text{ psi})^{0.3}$.
- The characteristic pull-out strength for greater concrete compressive strengths shall be increased by multiplying the tabular value by $(f'_c / 3,000 \text{ psi})^{0.4}$.
- Concrete shall be normal-weight or structural sand-lightweight concrete having a minimum specified compressive strength, f'_c , of 3,000 psi.
- Minimum distance to edge of panel is $2h_{ef}$.

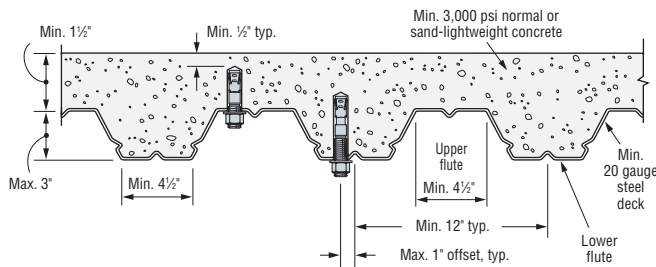

Strong-Bolt® 2 Wedge Anchor Performance Data

Carbon-Steel Strong-Bolt® 2 Wedge Anchor Tension and Shear Loads in 8-inch Lightweight, Medium-weight and Normal-Weight Grout-Filled CMU

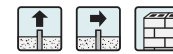

* See page 13 for an explanation of the load table icons

Size in. (mm)	Drill Bit Dia. in.	Min. Embed. Depth. in. (mm)	Install. Torque ft-lbs (N-m)	Critical Edge Dist. in. (mm)	Critical End Dist. in. (mm)	Critical Spacing in. (mm)	Tension Load		Shear Load	
							Ultimate lbs. (kN)	Allowable lbs. (kN)	Ultimate lbs. (kN)	Allowable lbs. (kN)
Anchor Installed in the Face of the CMU Wall (See Figure 1)										
3/8 (9.5)	3/8	2 5/8 (67)	20 (27.1)	12 (305)	12 (305)	8 (203)	2,185 (9.7)	435 (1.9)	3,875 (17.2)	775 (3.4)
1/2 (12.7)	1/2	3 1/2 (89)	35 (47.5)	12 (305)	12 (305)	8 (203)	2,645 (11.8)	530 (2.4)	5,055 (22.5)	1,010 (4.5)
5/8 (15.9)	5/8	4 3/8 (111)	55 (74.6)	20 (508)	20 (508)	8 (203)	4,460 (19.8)	890 (4.0)	8,815 (39.2)	1,765 (7.9)
3/4 (19.1)	3/4	5 1/4 (133)	100 (135.6)	20 (508)	20 (508)	8 (203)	5,240 (23.3)	1050 (4.7)	12,450 (55.4)	2,490 (11.1)

- The tabulated allowable loads are based on a safety factor of 5.0 for installation under the IBC and IRC.
- Listed loads may be applied to installations on the face of the CMU wall at least 1 1/4 inch away from headjoints.
- Values for 8-inch wide concrete masonry units (CMU) with a minimum specified compressive strength of masonry, f'_m , at 28 days is 1500 psi.
- Embedment depth is measured from the outside face of the concrete masonry unit.
- Tension and shear loads may be combined using the parabolic interaction equation ($n = 5/3$).
- Refer to allowable load adjustment factors for edge distance and spacing on page 105.

Figure 1

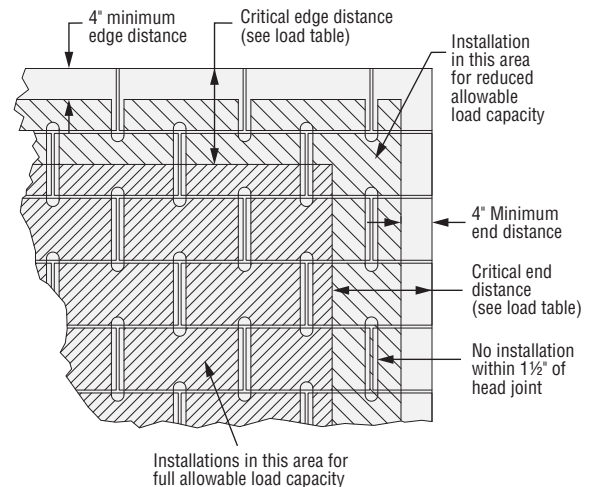

Carbon-Steel Strong-Bolt® 2 Wedge Anchor Tension and Shear Loads in 8-inch Lightweight, Medium-weight and Normal-Weight Grout-Filled CMU



* See page 13 for an explanation of the load table icons

Size in. (mm)	Drill Bit Dia. in.	Min. Embed. Depth. in. (mm)	Install. Torque ft-lbs (N-m)	Min. Edge. Dist. in. (mm)	Critical End Dist. in. (mm)	Critical Spacing in. (mm)	Tension Load		Shear Load Perp. To Edge		Shear Load Parallel To Edge	
							Ultimate lbs. (kN)	Allowable lbs. (kN)	Ultimate lbs. (kN)	Allowable lbs. (kN)	Ultimate lbs. (kN)	Allowable lbs. (kN)
Anchor Installed in Cell Opening or Web (Top of Wall) (See Figure 2)												
1/2 (12.7)	1/2	3 1/2 (89)	35 (47.5)	1 3/4 (44)	12 (305)	8 (203)	2,080 (9.3)	415 (1.8)	1,165 (5.2)	235 (1.0)	3,360 (14.9)	670 (3.0)
5/8 (15.9)	5/8	4 3/8 (111)	55 (74.6)	1 3/4 (44)	12 (305)	8 (203)	3,200 (14.2)	640 (2.8)	1,370 (6.1)	275 (1.2)	3,845 (17.1)	770 (3.4)

- The tabulated allowable loads are based on a safety factor of 5.0 for installation under the IBC and IRC.
- Values for 8-inch wide concrete masonry units (CMU) with a minimum specified compressive strength of masonry, f'_m , at 28 days is 1500 psi.
- Tension and shear loads may be combined using the parabolic interaction equation ($n = 5/3$).
- Refer to allowable load adjustment factors for edge distance and spacing on page 105.

Figure 2

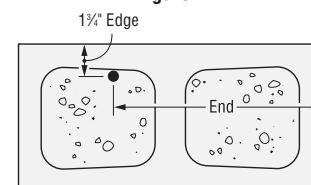

Strong-Bolt® 2 Wedge Anchor Performance Data

Load Adjustment Factors for Carbon-Steel Strong-Bolt® 2 Anchors in Face-of-Wall Installation in 8" Grout-Filled CMU: Edge Distance and Spacing, Tension and Shear Loads

How to use these charts:

1. The following tables are for reduced edge distance and spacing.
2. Locate the anchor size to be used for either a tension and/or shear load application.
3. Locate the embedment (E) at which the anchor is to be installed.
4. Located the edge distance (C_{act}) or spacing (S_{act}) at which the anchor is to be installed.
5. The load adjustment factor (f_c or f_s) is the intersection of the row and column.
6. Multiply the allowable load by the applicable load adjustment factor.
7. Reduction factors for multiple edges or spacings are multiplied together.

Edge or End Distance Tension (f_c)



* See page 13 for an explanation of the load table icons

C_{act} (in.)	Dia.	3/8	1/2	5/8	3/4
	E	2 3/8	3 1/2	4 3/8	5 1/4
	C_{cr}	12	12	20	20
	C_{min}	4	4	4	4
	f_{cmin}	1.00	1.00	1.00	0.97
4		1.00	1.00	1.00	0.97
6		1.00	1.00	1.00	0.97
8		1.00	1.00	1.00	0.98
10		1.00	1.00	1.00	0.98
12		1.00	1.00	1.00	0.99
14				1.00	0.99
16				1.00	0.99
18				1.00	1.00
20				1.00	1.00

Edge or End Distance Shear (f_c)

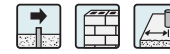

* See page 13 for an explanation of the load table icons

C_{act} (in.)	Dia.	3/8	1/2	5/8	3/4
	E	2 3/8	3 1/2	4 3/8	5 1/4
	C_{cr}	12	12	20	20
	C_{min}	4	4	4	4
	f_{cmin}	0.71	0.60	0.36	0.28
4		0.71	0.60	0.36	0.28
6		0.78	0.70	0.44	0.37
8		0.86	0.80	0.52	0.46
10		0.93	0.90	0.60	0.55
12		1.00	1.00	0.68	0.64
14				0.76	0.73
16				0.84	0.82
18				0.92	0.91
20				1.00	1.00

Spacing Tension (f_s)



* See page 13 for an explanation of the load table icons

S_{act} (in.)	Dia.	3/8	1/2	5/8	3/4
	E	2 3/8	3 1/2	4 3/8	5 1/4
	S_{cr}	8	8	8	8
	S_{min}	4	4	4	4
	f_{smin}	1.00	0.93	0.86	0.80
4		1.00	0.93	0.86	0.80
6		1.00	0.97	0.93	0.90
8		1.00	1.00	1.00	1.00

Spacing Shear (f_s)

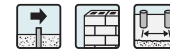

* See page 13 for an explanation of the load table icons

S_{act} (in.)	Dia.	3/8	1/2	5/8	3/4
	E	2 3/8	3 1/2	4 3/8	5 1/4
	S_{cr}	8	8	8	8
	S_{min}	4	4	4	4
	f_{smin}	1.00	1.00	1.00	1.00
4		1.00	1.00	1.00	1.00
6		1.00	1.00	1.00	1.00
8		1.00	1.00	1.00	1.00

Load Adjustment Factors for Carbon-Steel Strong-Bolt® 2 Anchors in Top-of-Wall Installation in 8" Grout-Filled CMU: Edge Distance and Spacing, Tension and Shear Loads

How to use these charts:

1. The following tables are for reduced edge distance and spacing.
2. Locate the anchor size to be used for either a tension and/or shear load application.
3. Locate the embedment (E) at which the anchor is to be installed.
4. Located the edge distance (C_{act}) or spacing (S_{act}) at which the anchor is to be installed.
5. The load adjustment factor (f_c or f_s) is the intersection of the row and column.
6. Multiply the allowable load by the applicable load adjustment factor.
7. Reduction factors for multiple edges or spacings are multiplied together.

End Distance Tension (f_c)



End Distance Shear Perpendicular to Edge (f_c)



End Distance Shear Parallel to Edge (f_c)



S_{act} (in.)	Dia.	1/2	5/8
	E	3 1/2	4 3/8
	C_{cr}	12	12
	C_{min}	4	4
	f_{cmin}	1.00	1.00
4		1.00	1.00
6		1.00	1.00
8		1.00	1.00
10		1.00	1.00
12		1.00	1.00

C_{act} (in.)	Dia.	1/2	5/8
	E	3 1/2	4 3/8
	C_{cr}	12	12
	C_{min}	4	4
	f_{cmin}	0.90	0.83
4		0.90	0.83
6		0.93	0.87
8		0.95	0.92
10		0.98	0.96
12		1.00	1.00

C_{act} (in.)	Dia.	1/2	5/8
	E	3 1/2	4 3/8
	C_{cr}	12	12
	C_{min}	4	4
	f_{cmin}	0.53	0.50
4		0.53	0.50
6		0.65	0.63
8		0.77	0.75
10		0.88	0.88
12		1.00	1.00

Spacing Tension (f_s)



Spacing Shear Perpendicular or Parallel to Edge (f_s)



* See page 13 for an explanation of the load table icons

S_{act} (in.)	Dia.	1/2	5/8
	E	3 1/2	4 3/8
	S_{cr}	8	8
	S_{min}	4	4
	f_{smin}	0.93	0.86
4		0.93	0.86
6		0.97	0.93
8		1.00	1.00

S_{act} (in.)	Dia.	1/2	5/8
	E	3 1/2	4 3/8
	S_{cr}	8	8
	S_{min}	4	4
	f_{smin}	1.00	1.00
4		1.00	1.00
6		1.00	1.00
8		1.00	1.00



Strong-Bolt® Wedge Anchor for Cracked and Uncracked Concrete

The Strong-Bolt® is a wedge anchor specifically designed for optimum performance in both cracked and uncracked concrete; a requirement that the 2009 IBC places on post-installed anchors. Rigorously tested according to the latest industry-wide criteria, the Strong-Bolt anchor is proven to offer increased reliability in the most adverse conditions, including performance in cracked concrete under static and seismic loading. The proprietary tri-segmented clip has dual undercutting embossments on each segment which enable secondary or "follow-up" expansion if a crack forms and intersects the anchor location. This significantly increases the ability of the Strong-Bolt wedge anchor to carry load if the hole opened slightly due to a crack. The Strong-Bolt anchor sets like a standard wedge anchor and is available in Imperial fractional sizes.

FEATURES:

- Tri-segmented clip: Each segment is able to adjust independently increasing follow-up expansion should the hole increase in size as a result of a crack.
- Dual embossments on each clip segment: Allows the clip to undercut into the concrete increasing follow-up expansion should a crack occur.
- 316 stainless steel clip: In addition to superior corrosion resistance, a stainless steel clip offers better "memory". This memory contributes to the anchor's performance should the hole size increase due to a crack.
- Imperial fractional sized anchor: Fits most fixtures and installs with common drill bits sizes and tools. No need to buy additional tools to install a metric anchor and no special couplers needed.
- Installs like a standard wedge anchor: No complicated installation procedure. No need for special bits or installation tools.
- The head is stamped with the Simpson Strong-Tie® "S" sign and size ID for easy post-installation identification

MATERIAL: Carbon-steel stud with 316 stainless-steel clip

FINISH: Zinc plated

CODES: ICC-ES ESR-1771; City of L.A. RR25705; Florida FL 11506.6

⚠ The load tables list values based upon results from the most recent testing and may not reflect those in current code reports. Where code jurisdictions apply, consult the current reports for applicable load values.

TEST CRITERIA: The Strong-Bolt wedge anchor has been tested in accordance with the ICC-ES *Acceptance Criteria for Mechanical Anchors in Concrete Elements (AC193)* and ACI 355.2 for the following:

- Static tension and shear loading in cracked and uncracked concrete
- Seismic and wind loading in cracked and uncracked concrete
- Performance in cracked concrete

Vibratory Load Testing: A 150 lb. concrete block was suspended from a ½" diameter anchor embedded at 2¼" and vibrated for 12.6 million cycles at a frequency of 30 Hz and an amplitude of 0.025 inches. Subsequent load test showed no reduction in ultimate tension capacity.

INSTALLATION: • Do not use an impact wrench to set or tighten the Strong-Bolt anchor.

⚠ Caution: Oversized holes in the base material will make it difficult to set the anchor and will reduce the anchor's load capacity.

- Drill a hole in the base material using a carbide drill bit the same diameter as the nominal diameter of the anchor to be installed. Drill the hole to the specified embedment depth and blow it clean using compressed air. Overhead installations need not be blown clean. Alternatively, drill the hole deep enough to accommodate minimum hole depth and dust from drilling.
- Assemble the anchor with nut and washer so that the top of the nut is flush with the top of the anchor. Place the anchor in the fixture and drive into the hole until washer and nut are tight against the fixture.
- Tighten to the required installation torque.

APPLICATION:

- Interior environment where low levels of moisture and corrosive chemicals are present.

SUGGESTED SPECIFICATIONS:

Wedge anchors shall be an imperial-sized steel threaded stud with an integral cone expander and a three-segment expansion clip. The stud shall be manufactured from carbon steel and the expansion clip shall have two undercutting embossments per segment and be manufactured from 316 stainless steel. The anchor shall have been tested and qualified for performance in cracked concrete per ACI 355.2 and ICC-ES AC193. Anchors shall be Strong-Bolt® wedge anchors from Simpson Strong-Tie, Pleasanton, CA, and be installed following Simpson Strong-Tie instructions.

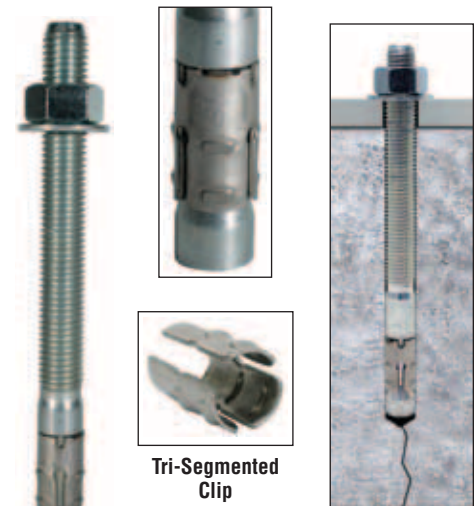

Strong-Bolt® Wedge Anchor

Installation Sequence

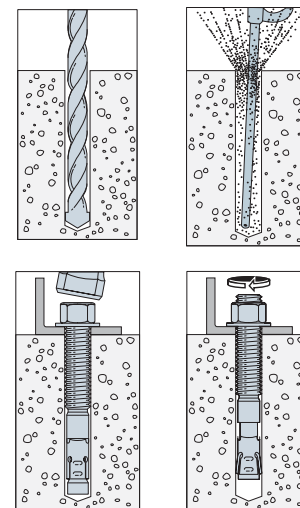

Strong-Bolt® Anchor Installation Data

Strong-Bolt Dia. (in.)	1/2	5/8	3/4	1
Bit Size (in.)	1/2	5/8	3/4	1
Min. Fixture Hole (in.)	9/16	11/16	7/8	1 1/8
Wrench Size (in.)	3/4	15/16	1 1/8	1 1/2

Length Identification Head Marks on Strong-Bolt Anchors (corresponds to length of anchor – inches).

Mark	A	B	C	D	E	F	G	H	I	J	K	L	M	N	O	P	Q	R	S	T	U	V	W	X	Y	Z
From	1 1/2	2	2 1/2	3	3 1/2	4	4 1/2	5	5 1/2	6	6 1/2	7	7 1/2	8	8 1/2	9	9 1/2	10	11	12	13	14	15	16	17	18
Up to but not including	2	2 1/2	3	3 1/2	4	4 1/2	5	5 1/2	6	6 1/2	7	7 1/2	8	8 1/2	9	9 1/2	10	11	12	13	14	15	16	17	18	19

Strong-Bolt® Wedge Anchor for Cracked and Uncracked Concrete

Strong-Bolt® Anchor Product Data

Size (in.)	Model No.	Drill Bit Dia. (in.)	Thread Length (in.)	Quantity	
				Box	Carton
1/2 x 3 3/4	STB50334	1/2	1 3/4	25	125
1/2 x 4 1/4	STB50414		2 1/4	25	100
1/2 x 5 1/2	STB50512		3 1/2	25	100
1/2 x 7	STB50700		5	25	100
1/2 x 8 1/2	STB50812		6	25	50
1/2 x 10	STB50100		6	25	50
5/8 x 4 1/2	STB62412	5/8	2 1/16	20	80
5/8 x 5	STB62500		2 9/16	20	80
5/8 x 6	STB62600		3 9/16	20	80
5/8 x 7	STB62700		4 9/16	20	80
5/8 x 8 1/2	STB62812		6	20	40
5/8 x 10	STB62100		6	10	20
3/4 x 5 1/2	STB75512	3/4	2 1/16	10	40
3/4 x 6 1/4	STB75614		3 7/16	10	40
3/4 x 7	STB75700		4 3/16	10	40
3/4 x 8 1/2	STB75812		5 1/16	10	20
3/4 x 10	STB75100		6	10	20
1 x 7	STB100700		1	3 1/2	5
1 x 10	STB1001000	3 1/2		5	10
1 x 13	STB1001300	3 1/2		5	10

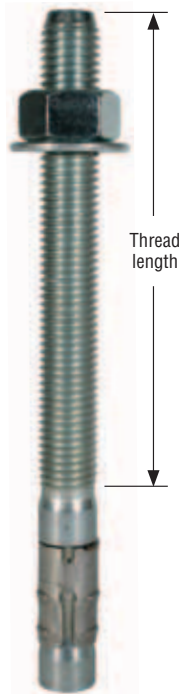

Material Specifications

Carbon Steel - Zinc Plated ¹			
Component Materials			
Anchor Body	Nut	Washer	Clip
Carbon Steel SAE J403, Grade 1030-1035 SAE J403, Grade 12L14	Carbon Steel ASTM A 563, Grade A	Carbon Steel ASTM F844	316 Stainless Steel

1. Zinc meets ASTM B 633, Class SC 1 (Fe / Zn 5), Type III.

1. The published length is the overall length of the anchor.
2. Allow one anchor diameter for the nut and washer thickness plus the fixture thickness when selecting a length.

Strong-Bolt® Anchor Installation Information and Additional Data¹

Characteristic	Symbol	Units	Nominal Anchor Diameter (inch)											
			1/2			5/8			3/4			1		
Installation Information														
Drill Bit Diameter	<i>d</i>	in.	1/2			5/8			3/4			1		
Baseplate Clearance Hole Diameter	<i>d_c</i>	in.	9/16			11/16			7/8			1 1/8		
Installation Torque	<i>T_{inst}</i>	ft-lb	50			85			180			230		
Embedment Depth	<i>h_{nom}</i>	in.	2 3/4	3 7/8	5	3 3/8	5 1/8	6 1/8	4 1/8	5 3/4	7 1/2	5 1/4	9 3/4	
Critical Edge Distance	<i>c_{ac}</i>	in.	9	7 7/8	6 3/4	11	9 5/8	8 1/4	13 1/2	11 3/4	10 1/8	18	13 1/2	
Minimum Edge Distance	<i>c_{min}</i>	in.	4			5			6			8		
Minimum Spacing	<i>s_{min}</i>	in.	4			6 1/4			6 1/4			8		
Minimum Concrete Thickness	<i>h_{min}</i>	in.	4 1/2	6	6 3/4	5 1/2	7 7/8	8 1/4	6 3/4	8 3/4	10 1/8	9	13 1/2	
Additional Data														
Anchor Category	category	-	1						2					
Yield Strength	<i>f_{ya}</i>	psi	108,000						60,000					
Tensile Strength	<i>f_{uta}</i>	psi	125,000						78,000					
Minimum Tensile & Shear Stress Area	<i>A_{se}</i>	in ²	0.108			0.167			0.273			0.472		
Axial Stiffness in Service Load Range	<i>β</i>	lb/in.	125,000			141,000			225,000			299,600		

1. The information presented in this table is to be used in conjunction with the design criteria of ACI 318 Appendix D.

Strong-Bolt® Wedge Anchor for Cracked and Uncracked Concrete



* See page 13 for an explanation of the load table icons

Tension Strength Design Data¹

Characteristic	Symbol	Units	Nominal Anchor Diameter (inch)											
			1/2			5/8			3/4			1		
Embedment Depth	h_{nom}	in.	2 3/4	3 7/8	5	3 3/8	5 1/8	6 1/8	4 1/8	5 3/4	7 1/2	5 1/4	9 3/4	
Steel Strength in Tension														
Nominal Steel Strength in Tension	N_{sa}	lb.	13,500			20,875			34,125			36,815		
Strength Reduction Factor – Steel Failure	ϕ	—	0.75 ²			0.75 ²			0.65 ²			0.65 ²		
Concrete Breakout Strength in Tension⁹														
Effective Embedment Depth	h_{ef}	in.	2.250	3.375	4.500	2.750	4.500	5.500	3.375	5.000	6.750	4.500	9.000	
Critical Edge Distance ⁷	c_{ac}	in.	9	7 7/8	6 3/4	11	9 5/8	8 1/4	13 1/2	11 3/4	10 1/8	18	13 1/2	
Effectiveness Factor – Uncracked Concrete	k_{uncr}	—	24											
Effectiveness Factor – Cracked Concrete	k_{cr}	—	17											
Modification Factor	$\psi_{c,N}$	—	1.00											
Strength Reduction Factor – Concrete Breakout Failure	ϕ	—	0.65 ⁸						0.55 ⁸					
Pullout Strength in Tension¹⁰														
Nominal Pullout Strength Uncracked Concrete ($f'_c = 2,500$ psi)	$N_{p,uncr}$	lb	— ³	4,120 ⁵	4,600 ⁵	— ³	7,250 ⁴	7,300 ⁴	— ³	9,420 ⁵	12,115 ⁵	8,360 ⁵	9,690 ⁵	
Nominal Pullout Strength Cracked Concrete ($f'_c = 2,500$ psi)	$N_{p,cr}$	lb	— ³	2,995 ⁵	2,995 ⁵	— ³	5,200 ⁴	5,260 ⁴	— ³	— ³	9,850 ⁵	7,700 ⁵	11,185 ⁵	
Strength Reduction Factor – Pullout Failure	ϕ	—	—	0.65 ⁶	0.65 ⁶	—	0.65 ⁶	0.65 ⁶	—	0.55 ⁶	0.55 ⁶	0.55 ⁶	0.55 ⁶	
Pullout Strength in Tension for Seismic Applications¹⁰														
Nominal Pullout Strength of Single Anchor for Seismic Loads ($f'_c = 2,500$ psi)	$N_{p,eq}$	lb	— ³	2,995 ⁵	2,995 ⁵	— ³	5,200 ⁴	5,260 ⁴	— ³	— ³	9,850 ⁵	7,700 ⁵	11,185 ⁵	
Strength Reduction Factor – Pullout Failure	ϕ	—	—	0.65 ⁶	0.65 ⁶	—	0.65 ⁶	0.65 ⁶	—	—	0.55 ⁶	0.55 ⁶	0.55 ⁶	

Mechanical Anchors

- The information presented in this table is to be used in conjunction with the design criteria of ACI 318 Appendix D, except as modified below.
- The value of ϕ applies when the load combinations of ACI 318 Section 9.2 are used. If the load combinations of ACI 318 Appendix C are used, refer to Section D4.5 to determine the appropriate value of ϕ . The 3/4 inch and 1 inch diameter are considered as a brittle steel element. The 1/2 inch and 5/8 inch diameters are considered as ductile steel elements.
- Pullout strength is not reported since concrete breakout controls.
- Adjust the characteristic pullout resistance for other concrete compressive strengths by multiplying the tabular value by $(f'_{c,specified} / 2,500)^{0.7}$.
- Adjust the characteristic pullout resistance for other concrete compressive strengths by multiplying the tabular value by $(f'_{c,specified} / 2,500)^{0.5}$.
- The value of ϕ applies when both the load combinations of ACI 318 Section 9.2 are used and the requirements of Section D4.4(c) for Condition B are met. If the load combinations of ACI 318 Appendix C are used, refer to Section D4.5 to determine the appropriate value of ϕ .
- The modification factor $\psi_{cp,N} = 1.0$ for cracked concrete. Otherwise, the modification factor for uncracked concrete without supplementary reinforcement to control splitting is either:
 (1) $\psi_{cp,N} = 1.0$ if $c_{a,min} \geq c_{ac}$ or (2) $\psi_{cp,N} = \frac{c_{a,min}}{c_{ac}} \geq \frac{1.5h_{ef}}{c_{ac}}$ if $c_{a,min} < c_{ac}$.
- The value of ϕ applies when both the load combinations of ACI 318 Section 9.2 are used and the requirements of Section D4.4(c) for Condition B are met. If the load combinations of ACI 318 Appendix C are used, refer to Section D4.5 to determine the appropriate value of ϕ .
- For sand-lightweight concrete, in lieu of ACI 318 Section D.3.4, modify the value of concrete breakout strength by 0.60. All-lightweight concrete is beyond the scope of this table.
- For sand-lightweight concrete, modify the value of $N_{p,cr}$, $N_{p,uncr}$ and N_{eq} by 0.60. All-lightweight concrete is beyond the scope of this table.

The modification factor, $\psi_{cp,N}$ is applied to the nominal concrete breakout strength, N_{cb} or N_{cbg} .

Shear Strength Design Data¹

* See page 13 for an explanation of the load table icons

Characteristic	Symbol	Units	Nominal Anchor Diameter (inch)										
			1/2			5/8			3/4			1	
Embedment Depth	h_{nom}	in.	2 3/4	3 7/8	5	3 3/8	5 1/8	6 1/8	4 1/8	5 3/4	7 1/2	5 1/4	9 3/4
Steel Strength in Shear													
Nominal Steel Strength in Shear	V_{sa}	lb.	5,280			7,255			10,650			15,020	
Strength Reduction Factor – Steel Failure	ϕ	–	0.65 ²			0.65 ²			0.60 ²			0.60 ²	
Concrete Breakout Strength in Shear⁵													
Outside Diameter	d_o	in.	0.5			0.625			0.75			1.00	
Load Bearing Length of Anchor in Shear	ℓ_e	in.	2.25	3.375	4.00	2.75	4.50	5.00	3.375	5.00	6.00	4.50	8.00
Strength Reduction Factor – Concrete Breakout Failure	ϕ	–	0.70 ³										
Concrete Pryout Strength in Shear													
Coefficient for Pryout Strength	k_{cp}	–	1.0	2.0									
Strength Reduction Factor – Concrete Pryout Failure	ϕ	–	0.70 ⁴										
Steel Strength in Shear for Seismic Applications													
Nominal Steel Strength in Shear for Seismic Loads	V_{eq}	lb	5,280			7,255			10,650			15,020	
Strength Reduction Factor – Steel Failure	ϕ	–	0.65 ²			0.65 ²			0.60 ²			0.60 ²	

- The information presented in this table is to be used in conjunction with the design criteria of ACI 318 Appendix D, except as modified below.
- The value of ϕ applies when the load combinations of ACI 318 Section 9.2 are used. If the load combinations of ACI 318 Appendix C are used, refer to Section D4.5 to determine the appropriate value of ϕ . The 3/4 inch and 1 inch diameter are considered as a brittle steel element. The 1/2 inch and 5/8 inch diameters are considered as ductile steel elements.
- The value of ϕ applies when both the load combinations of ACI 318 Section 9.2 are used and the requirements of Section D4.4(c) for Condition B are met. If the load combinations of ACI 318 Section 9.2 are used and the requirements of Section D4.4(c) for Condition A are met, refer to Section D4.4 to determine the appropriate value of ϕ . If the load combinations of ACI 318 Appendix C are used, refer to Section D4.5 to determine the appropriate value of ϕ .
- The value of ϕ applies when both the load combinations of ACI 318 Section 9.2 are used and the requirements of Section D4.4(c) for Condition B are met. If the load combinations of ACI 318 Appendix C are used, refer to Section D4.5 to determine the appropriate value of ϕ .
- For sand-lightweight concrete, in lieu of ACI 318 Section D.3.4, modify the value of concrete breakout strength by 0.60. All-lightweight concrete is beyond the scope of this table.

Titen HD® Heavy Duty Screw Anchor for Cracked and Uncracked Concrete



The Titen HD® anchor is a patented, high-strength screw anchor for concrete and masonry. It is designed for optimum performance in both cracked and uncracked concrete; a requirement that the 2009 IBC places on post-installed anchors. The high strength, easy to install Titen HD anchor has been tested and shown to provide outstanding performance in cracked and uncracked concrete under both static and seismic loading conditions. The self-undercutting, non-expansion characteristics of the Titen HD anchor make it ideal for structural applications, even at reduced edge distances and spacings. Recommended for permanent dry, interior non-corrosive environments or temporary outdoor applications.

PERFORMANCE FEATURES:

- Tested per AC193 to ensure outstanding performance in both cracked and uncracked concrete
- Higher load capacity and vibration resistance: Threads along the length of the anchor undercut the concrete and efficiently transfer the load to the base material.
- Vibration and shock resistance: The mechanical interlock of the threads and the ratchet teeth on the underside of the head help prevent the anchor from loosening in vibratory conditions. The Titen HD anchor has been tested to 12.6 million vibratory cycles with no performance reductions.
- Specialized heat treating process: Creates superior surface hardness at the tip to facilitate cutting, while at the same time not compromising ductility within the anchor body.
- Less spacing and edge distance required: The anchor does not exert expansion forces on the base material.
- Easy post-installation inspection: The head is stamped with the Simpson Strong-Tie® "≠" sign and the anchor length in inches.

INSTALLATION FEATURES:

- No special drill bit needed: Designed to install using standard sized ANSI tolerance drill bits
- Installs with 50% less torque: Testing shows that when compared to competitors, the Titen HD requires 50% less torque to be installed in concrete.
- Hex-washer head: Requires no separate washer and provides a clean installed appearance.*
- Removable: Ideal for temporary anchoring (e.g. formwork, bracing) or applications where fixtures may need to be moved. Re-use of the anchor to achieve listed load values is not recommended. See reinstallation note on next page.

MATERIAL: Carbon steel, heat treated

FINISH: Zinc plated or mechanically galvanized

CODES: ICC-ES ESR-2713 (concrete); ICC-ES ESR-1056 (CMU); City of L.A. RR25741 (concrete) City of L.A. RR25560 (CMU); Florida FL 11506.7; Factory Mutual 3017082, 3035761 and 3043442.

⚠ The load tables list values based upon results from the most recent testing and may not reflect those in current code reports. Where code jurisdictions apply, consult the current reports for applicable load values.

TEST CRITERIA: The Titen HD® anchor has been tested in accordance with ICC-ES AC193, ACI 355.2 and ICC-ES AC106 for the following:

- Static tension and shear loading in cracked and uncracked concrete
- Seismic and wind loading in cracked and uncracked concrete
- Performance in uncracked masonry

Anchor Fatigue Testing: Tested in accordance with ASTM E 488 for the effects of fatigue. 25% of the average ultimate load was applied to the anchor for 2 million cycles at a frequency of 15 Hz. Subsequent load tests showed no reduction in ultimate tension capacity.

Vibratory Load Testing: A 150 lb. concrete block was suspended from a 3/8" diameter anchor embedded at 1 1/2" and vibrated for 12.6 million cycles at a frequency of 30 Hz and an amplitude of 0.0325 inches. Subsequent load test showed no reduction in ultimate tension capacity.

Field Testing: For guidance on field testing see technical bulletin T-SAS-THDINSP.

INSTALLATION: Holes in metal fixtures to be mounted should match the diameter specified in the table on the next page.

⚠ Caution: Oversized holes in the base material will reduce or eliminate the mechanical interlock of the threads with the base material and will reduce the anchor's load capacity. Use a Titen HD screw anchor one time only. Installing the anchor multiple times may result in excessive thread wear and reduce load capacity.

- Drill a hole in the base material using a carbide drill bit the same diameter as the nominal diameter of the anchor to be installed. Drill the hole to the specified embedment depth plus 1/2" minimum to allow the thread tapping dust to settle and blow it clean using compressed air. Overhead installations need not be blown clean. Alternatively, drill the hole deep enough to accommodate embedment depth and dust from drilling and tapping.
- Insert the anchor through the fixture and into the hole.
- Tighten the anchor into the base material until the hex washer head contacts the fixture.
- Do not use impact wrenches to install into hollow CMU.

SUGGESTED SPECIFICATIONS: Screw anchors shall have 360-degree contact with the base material and shall not require oversized holes for installation. Fasteners shall be manufactured from carbon steel, and are heat-treated. Anchors shall be zinc plated in accordance with ASTM B633 or mechanically galvanized in accordance with ASTM B695. Anchors are not to be reused after initial installation. Screw anchors shall be Titen HD® anchors from Simpson Strong-Tie, Pleasanton, CA. Anchors shall be installed per the Simpson Strong-Tie instructions for the Titen HD anchor.

*Some jurisdictions require an additional square plate washer for sill plate applications.



**Titen HD®
Screw Anchor**
U.S. Patent
5,674,035 &
6,623,228



Serrated teeth on the tip of the Titen HD® screw anchor facilitate cutting and reduce installation torque.

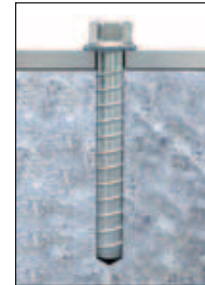

Suitable for use in place of code anchor bolts.



Longer 1/2" diameter Titen HD anchors achieve sufficient embedment depth to develop tension loads equal to many Simpson Strong-Tie holdowns that specify a 3/4" diameter anchor. Testing has been conducted to assure compatibility of these holdowns' anchor holes with the 1/2" Titen HD screw anchor.

Installation Sequence

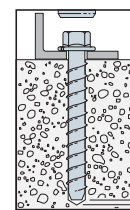
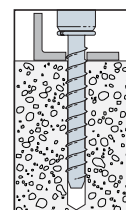
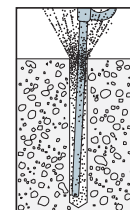
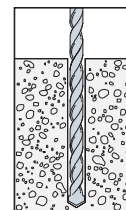

Titen HD® Heavy Duty Screw Anchor for Cracked and Uncracked Concrete

Titen HD® Anchor Product Data - Zinc Plated

Size (in.)	Model No.	Drill Bit Dia. (in.)	Wrench Size (in.)	Quantity			
				Box	Carton		
3/8 x 3	THD37300H	3/8	9/16	50	200		
3/8 x 4	THD37400H			50	200		
3/8 x 5	THD37500H			50	100		
3/8 x 6	THD37600H			50	100		
1/2 x 3	THD50300H	1/2	3/4	25	100		
1/2 x 4	THD50400H			20	80		
1/2 x 5	THD50500H			20	80		
1/2 x 6	THD50600H			20	80		
1/2 x 6 1/2	THD50612H			20	40		
1/2 x 8	THD50800H			20	40		
1/2 x 12	THD501200H			20	40		
1/2 x 13	THD501300H			20	40		
1/2 x 14	THD501400H			20	40		
1/2 x 15	THD501500H			20	40		
5/8 x 4	THD62400H			5/8	15/16	10	40
5/8 x 5	THD62500H					10	40
5/8 x 6	THD62600H	10	40				
5/8 x 6 1/2	THD62612H	10	40				
5/8 x 8	THD62800H	5/8	15/16	10	20		
5/8 x 4	THDB62400H			10	40		
5/8 x 5	THDB62500H			10	40		
5/8 x 6	THDB62600H			10	40		
5/8 x 6 1/2	THDB62612H			10	40		
5/8 x 8	THDB62800H			10	20		
3/4 x 4	THD75400H			3/4	1 1/8	10	40
3/4 x 5	THD75500H					5	20
3/4 x 6	THDT75600H	5	20				
3/4 x 7	THD75700H	5	10				
3/4 x 8 1/2	THD75812H	5	10				
3/4 x 10	THD75100H	5	10				

1. Zinc plating meets ASTM B633, SC1.
2. Length is measured from the underside of the head to the tip of the anchor.



FIXTURE HOLE DIAMETER:

Due to the full shank diameter and larger threads of the Titen HD® screw anchor, consideration needs to be given to specifying the appropriate diameter Titen HD anchor based on the fixture hole type to be used. The American Institute of Steel Construction (AISC) has established the following guidelines with regards to fixture hole sizing depending on the hole type:

- “Standard” fixture holes are 1/16" larger than the nominal anchor diameter.
- “Oversized” fixture holes are 1/8" - 3/16" larger than the nominal anchor diameter, depending upon the specific anchor diameter.

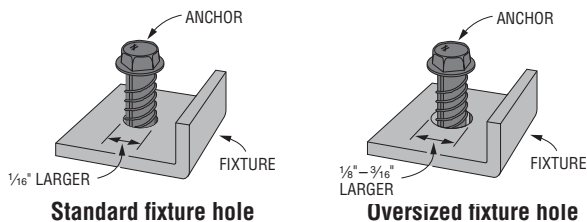

Use the following table to identify which diameter Titen HD® screw anchor to use based on the fixture hole type and diameter. In most cases where a smaller diameter Titen HD anchor is called out in comparison to the competitor's larger diameter anchor, the Titen HD anchor still generally provides allowable tension and shear load values comparable to or greater than those of the competitor's anchor.

Titen HD Anchor Product Data - Mechanically Galvanized

Size (in.)	Model No.	Drill Bit Dia. (in.)	Wrench Size (in.)	Quantity	
				Box	Carton
3/8 x 5	THD37500HMG	3/8	9/16	50	100
3/8 x 6	THD37600HMG			50	100
1/2 x 5	THD50500HMG	1/2	3/4	20	80
1/2 x 6	THD50600HMG			20	80
1/2 x 6 1/2	THD50612HMG			20	40
1/2 x 8	THD50800HMG			20	40
5/8 x 5	THD62500HMG	5/8	15/16	10	40
5/8 x 6	THD62600HMG			10	40
5/8 x 6 1/2	THD62612HMG			10	40
5/8 x 8	THD62800HMG			10	20
5/8 x 5	THDB62500HMG	5/8	15/16	10	40
5/8 x 6	THDB62600HMG			10	40
5/8 x 6 1/2	THDB62612HMG			10	40
5/8 x 8	THDB62800HMG			10	20
3/4 x 8 1/2	THD75812HMG	3/4	1 1/8	5	10
3/4 x 10	THD75100HMG			5	10

1. Mechanical galvanizing meets ASTM B695, Class 65, Type 1. Intended for some pressure-treated wood sill plate applications. Not for use in other corrosive or outdoor environments. See page 11 or visit www.strongtie.com/info for more corrosion information.



The Titen HD® screw anchor 3/8" x 6" and 3/8" x 7" (models THDT75600H and THD75700H) have a 1" section under the head that is unthreaded to allow installation into tilt-up wall braces.



Hole Dimensions

Titen HD Diameter (in.)	Wrench Size (in.)	Recommended Fixture Hole Size (in.)
3/8	9/16	1/2 to 9/16
1/2	3/4	5/8 to 11/16
5/8	15/16	3/4 to 13/16
3/4	1 1/8	7/8 to 15/16



Titen HD® Heavy Duty Screw Anchor for Cracked and Uncracked Concrete

Titen HD® Anchor Installation Information and Additional Data¹

Characteristic	Symbol	Units	Nominal Anchor Diameter (in.)							
			3/8	1/2	5/8 ⁴	3/4				
Installation Information										
Drill Bit Diameter	d_{bit}	in.	3/8	1/2	5/8	3/4				
Baseplate Clearance Hole Diameter	d_c	in.	1/2	5/8	3/4	7/8				
Maximum Installation Torque	$T_{inst,max}$	ft-lb	50 ²	65 ²	100 ²	150 ²				
Maximum Impact Wrench Torque Rating	$T_{impact,max}$	ft-lb	150 ³	340 ³	340 ³	385 ³				
Embedment Depth	h_{nom}	in.	2 1/2	3 1/4	3 1/4	4	4	5 1/2	5 1/2	6 1/4
Critical Edge Distance	c_{ac}	in.	2 11/16	3 5/8	3 3/8	4 1/2	4 1/2	6 3/8	6 3/8	7 5/16
Minimum Edge Distance	c_{min}	in.	1 3/4							
Minimum Spacing	s_{min}	in.	3							
Minimum Concrete Thickness	h_{min}	in.	3 3/4	5	5	6 1/4	6	8 1/2	8 3/4	10
Additional Data										
Anchor Category	category	—	1							
Yield Strength	f_{ya}	psi	97,000							
Tensile Strength	f_{uta}	psi	110,000							
Minimum Tensile & Shear Stress Area	A_{se}	in ²	0.099	0.183	0.276	0.414				
Axial Stiffness in Service Load Range - Uncracked Concrete	β_{uncr}	lb/in.	715,000							
Axial Stiffness in Service Load Range - Cracked Concrete	β_{cr}	lb/in.	345,000							

1. The information presented in this table is to be used in conjunction with the design criteria of ACI 318 Appendix D.
2. $T_{inst,max}$ is the maximum permitted installation torque for the embedment depth range covered by this table for installations using a torque wrench. This is not applicable to other embedment depths published elsewhere in this catalog.

3. $T_{impact,max}$ is the maximum permitted torque rating for impact wrenches for the embedment depth range covered by this table. This is not applicable to other embedment depths published elsewhere in this catalog.
4. Data for 5/8" anchor is only valid for THDB62 series.

Titen HD® Heavy Duty Screw Anchor for Cracked and Uncracked Concrete

*See page 13 for an explanation of the load table icons



Titen HD® Anchor Tension Strength Design Data¹

Characteristic	Symbol	Units	Nominal Anchor Diameter (in.)							
			3/8	1/2	5/8 ³	3/4	1	1 1/4	1 1/2	1 3/4
Embedment Depth	h_{nom}	in.	2 1/2	3 1/4	3 1/4	4	4	5 1/2	5 1/2	6 1/4
Steel Strength in Tension										
Tension Resistance of Steel	N_{sa}	lb.	10,890		20,130		30,360		45,540	
Strength Reduction Factor - Steel Failure	ϕ	—	0.65 ²							
Concrete Breakout Strength in Tension^{6,8}										
Effective Embedment Depth	h_{ef}	in.	1.77	2.40	2.35	2.99	2.97	4.24	4.22	4.86
Critical Edge Distance ⁶	c_{ac}	in.	2 1/16	3/8	3/16	4 1/2	4 1/2	6 3/8	6 3/8	7 5/16
Effectiveness Factor - Uncracked Concrete	k_{un-cr}	—	24							
Effectiveness Factor - Cracked Concrete	k_{cr}	—	17							
Modification Factor	$\psi_{c,N}$	—	1.0							
Strength Reduction Factor - Concrete Breakout Failure	ϕ	—	0.65 ⁷							
Pullout Strength in Tension⁸										
Pullout Resistance, Uncracked Concrete ($f'_c=2,500$ psi)	$N_{p,un-cr}$	lb.	2,700 ⁴	— ³	— ³	— ³	— ³	9810	— ³	— ³
Pullout Resistance, Cracked Concrete ($f'_c=2,500$ psi)	$N_{p,cr}$	lb.	1,235 ⁴	2,700 ⁴	— ³	— ³	3260 ⁴	5570 ⁴	6,070 ⁴	7,195 ⁴
Strength Reduction Factor - Pullout Failure	ϕ	—	0.65 ⁵							
Breakout or Pullout Strength in Tension for Seismic Applications⁸										
Nominal Pullout Strength for Seismic Loads ($f'_c=2,500$ psi)	$N_{p,eq}$	lb.	1,235 ⁴	2,700 ⁴	— ³	— ³	3260 ⁴	5570 ⁴	6,070 ⁴	7,195 ⁴
Strength Reduction Factor - Breakout or Pullout Failure	ϕ	—	0.65 ⁵							

- The information presented in this table is to be used in conjunction with the design criteria of ACI 318 Appendix D, except as modified below.
- The value of ϕ applies when the load combinations of ACI 318 Section 9.2 are used. If the load combinations of ACI 318 Appendix C are used, refer to Section D4.5 to determine the appropriate value of ϕ . Anchors are considered brittle steel elements.
- Pullout strength is not reported since concrete breakout controls.
- Adjust the characteristic pullout resistance for other concrete compressive strengths by multiplying the tabular value by $(f'_c, \text{specified} / 2,500)^{0.5}$.
- The value of ϕ applies when both the load combinations of ACI 318 Section 9.2 are used and the requirements of Section D4.4(c) for Condition B are met. If the load combinations of ACI 318 Appendix C are used, refer to Section D4.5 to determine the appropriate value of ϕ .
- The modification factor $\psi_{cp,N} = 1.0$ for cracked concrete. Otherwise, the modification factor for uncracked concrete without supplementary reinforcement to control splitting is either: (1) $\psi_{cp,N} = 1.0$ if $c_{a,min} \geq c_{ac}$ or (2) $\psi_{cp,N} = \frac{c_{a,min}}{c_{ac}} \geq \frac{1.5h_{ef}}{c_{ac}}$ if $c_{a,min} < c_{ac}$. The modification factor, $\psi_{cp,N}$ is applied to the nominal concrete breakout strength, N_{cb} or N_{cbg} .
- The value of ϕ applies when both the load combinations of ACI 318 Section 9.2 are used and the requirements of Section D4.4(c) for Condition B are met. If the load combinations of ACI 318 Section 9.2 are used and the requirements of Section D4.4(c) for Condition A are met, refer to Section D4.4 to determine the appropriate value of ϕ . If the load combinations of ACI 318 Appendix C are used, refer to Section D4.5 to determine the appropriate value of ϕ .
- For sand-lightweight concrete, in lieu of ACI 318 Section D.3.4, modify the value of concrete breakout strength, $N_{p,cr}$, $N_{p,un-cr}$ and N_{eq} by 0.6. All-lightweight concrete is beyond the scope of this table.
- Data for 3/8" anchor is only valid for THDB62 series.

Titen HD® Heavy Duty Screw Anchor for Cracked and Uncracked Concrete

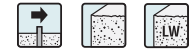

* See page 13 for an explanation of the load table icons

Titen HD® Anchor Shear Strength Design Data¹

Characteristic	Symbol	Units	Nominal Anchor Diameter (in.)							
			3/8		1/2		5/8 ⁵		3/4	
Embedment Depth	h_{nom}	in.	2 1/2	3 1/4	3 1/4	4	4	5 1/2	5 1/2	6 1/4
Steel Strength in Shear										
Shear Resistance of Steel	V_{sa}	lb.	4,460		7,455		10,000		16,840	
Strength Reduction Factor - Steel Failure	ϕ	—	0.60 ²							
Concrete Breakout Strength in Shear⁶										
Outside Diameter	d_o	in.	0.375		0.500		0.625		0.750	
Load Bearing Length of Anchor in Shear	ℓ_e	in.	1.77	2.40	2.35	2.99	2.97	4.24	4.22	4.86
Strength Reduction Factor - Concrete Breakout Failure	ϕ	—	0.70 ³							
Concrete Pryout Strength in Shear										
Coefficient for Pryout Strength	k_{cp}	—	1.0				2.0			
Strength Reduction Factor - Concrete Pryout Failure	ϕ	—	0.70 ⁴							
Steel Strength in Shear for Seismic Applications										
Shear Resistance of Single Anchor for Seismic Loads	V_{eq}	lb.	2,855		4,790		8,000		9,350	
Strength Reduction Factor - Steel Failure	ϕ	—	0.60 ²							

- The information presented in this table is to be used in conjunction with the design criteria of ACI 318 Appendix D, except as modified below.
- The value of ϕ applies when the load combinations of ACI 318 Section 9.2 are used. If the load combinations of ACI 318 Appendix C are used, refer to Section D4.5 to determine the appropriate value of ϕ . Anchors are considered brittle steel elements.
- The value of ϕ applies when both the load combinations of ACI 318 Section 9.2 are used and the requirements of Section D4.4(c) for Condition B are met. If the load combinations of ACI 318 Section 9.2 are used and the requirements of Section D4.4(c) for Condition A are met, refer to Section D4.4 to determine the appropriate value of ϕ . If the load combinations of ACI 318 Appendix C are used, refer to Section D4.5 to determine the appropriate value of ϕ .

- The value of ϕ applies when both the load combinations of ACI 318 Section 9.2 are used and the requirements of Section D4.4(c) for Condition B are met. If the load combinations of ACI 318 Appendix C are used, refer to Section D4.5 to determine the appropriate value of ϕ .
- Data for 3/8" anchor is only valid for THDB62 series.
- For sand-lightweight concrete, in lieu of ACI 318 Section D.3.4, modify the value of concrete breakout strength by 0.6. All-lightweight concrete is beyond the scope of this table.

Mechanical Anchors

Titen HD® Tension and Shear Strength Design Data for Normal-Weight or Sand-Lightweight Concrete over Metal Deck^{1,2,6}



* See page 13 for an explanation of the load table icons

Characteristic	Symbol	Units	Lower Flute				Upper Flute	
			Nominal Anchor Diameter (inch)				Nom. Anch. Diameter (inch)	
			3/8	1/2	3/8	1/2		
Embedment Depth	h_{nom}	in.	1 7/8	2 1/2	2	3 1/2	1 7/8	2
Effective Embedment Depth	h_{ef}	in.	1.23	1.77	1.29	2.56	1.23	1.29
Pullout Resistance, concrete on metal deck (cracked) ^{3,4}	$N_{p,deck,cr}$	lbs.	375	870	905	2,040	500	1,700
Pullout Resistance, concrete on metal deck (uncracked) ^{3,4}	$N_{p,deck,uncr}$	lbs.	825	1,905	1,295	2,910	1,095	2,430
Steel Strength in Shear, concrete on metal deck ⁵	$V_{sa,deck}$	lbs.	2,240	2,395	2,435	4,430	4,180	7,145
Steel Strength in Shear, Seismic	$V_{sa,deck,eq}$	lbs.	1,434	1,533	1,556	2,846	2,676	4,591

- The information presented in this table is to be used in conjunction with the design criteria of ACI 318 Appendix D, except as modified below.
- Concrete compressive strength shall be 3,000 psi minimum. The characteristic pullout resistance for greater compressive strengths shall be increased by multiplying the tabular value by $(f'_{c,specified} / 3,000 \text{ psi})^{1/2}$.
- For anchors installed in the soffit of sand-lightweight or normal-weight concrete over metal deck floor and roof assemblies, as shown in Figure A, calculation of the concrete breakout strength may be omitted.
- In accordance with ACI 318 Section D.5.3.2, the nominal pullout strength in cracked concrete for anchors installed in the soffit of sand-lightweight or normal-weight-concrete-over-metal-deck floor and roof assemblies $N_{p,deck,cr}$ shall be substituted for $N_{p,cr}$. Where analysis indicates no cracking at service loads, the normal pullout strength in uncracked concrete $N_{p,deck,uncr}$ shall be substituted for $N_{p,uncr}$.
- In accordance with ACI 318 Section D.6.1.2 (c), the shear strength for anchors installed in the soffit of sand-lightweight or normal-weight concrete over metal deck floor and roof assemblies $V_{sa,deck}$ and $V_{sa,deck,eq}$ shall be substituted for V_{sa} .
- Minimum distance to edge of panel is $2h_{ef}$.
- The minimum anchor spacing along the flute must be the greater of $3h_{ef}$ or 1.5 times the flute width.

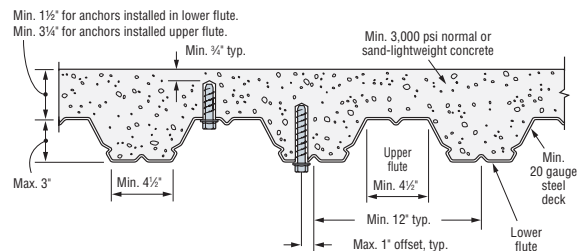
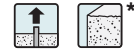

Figure A – Installation in Concrete over Metal Deck

Titen HD® Heavy Duty Screw Anchor for Cracked and Uncracked Concrete



Tension Loads in Normal-Weight Concrete

Size in. (mm)	Drill Bit Dia. in.	Embed. Depth in. (mm)	Critical Edge Dist. in. (mm)	Critical Spacing Dist. in. (mm)	Tension Load						
					f _c ≥ 2000 psi (13.8 MPa) Concrete			f _c ≥ 3000 psi (20.7 MPa) Concrete	f _c ≥ 4000 psi (27.6 MPa) Concrete		
					Ultimate lbs. (kN)	Std. Dev. lbs. (kN)	Allowable lbs. (kN)	Allowable lbs. (kN)	Ultimate lbs. (kN)	Std. Dev. lbs. (kN)	Allowable lbs. (kN)
3/8 (9.5)	3/8	2 3/4 (70)	3 (76)	6 (152)	4,297 (19.1)	—	1,075 (4.8)	1,315 (5.8)	6,204 (27.6)	—	1,550 (6.9)
		3 3/4 (95)			7,087 (31.5)	347 (1.5)	1,770 (7.9)	2,115 (9.4)	9,820 (43.7)	1,434 (6.4)	2,455 (10.9)
1/2 (12.7)	1/2	2 3/4 (70)	4 (102)	8 (203)	4,610 (20.5)	—	1,155 (5.1)	1,400 (6.2)	6,580 (29.3)	—	1,645 (7.3)
		3 5/8 (92)			7,413 (33.0)	412 (1.8)	1,855 (8.3)	2,270 (10.1)	10,742 (47.8)	600 (2.7)	2,685 (11.9)
		5 3/4 (146)			10,278 (45.7)	297 (1.3)	2,570 (11.4)	3,240 (14.4)	15,640 (69.6)	2,341 (10.4)	3,910 (17.4)
5/8 (15.9)	5/8	2 3/4 (70)	5 (127)	10 (254)	4,610 (20.5)	—	1,155 (5.1)	1,400 (6.2)	6,580 (29.3)	—	1,645 (7.3)
		4 1/8 (105)			8,742 (38.9)	615 (2.7)	2,185 (9.7)	2,630 (11.7)	12,286 (54.7)	1,604 (7.1)	3,070 (13.7)
		5 3/4 (146)			12,953 (57.6)	1,764 (7.8)	3,240 (14.4)	3,955 (17.6)	18,680 (83.1)	—	4,670 (20.8)
3/4 (19.1)	3/4	2 3/4 (70)	6 (152)	12 (305)	4,674 (20.8)	—	1,170 (5.2)	1,405 (6.3)	6,580 (29.3)	—	1,645 (7.3)
		4 5/8 (117)			10,340 (46.0)	1,096 (4.9)	2,585 (11.5)	3,470 (15.4)	17,426 (77.5)	1,591 (7.1)	4,355 (19.4)
		5 3/4 (146)			13,765 (61.2)	1,016 (4.5)	3,440 (15.3)	4,055 (18.0)	18,680 (83.1)	1,743 (7.8)	4,670 (20.8)

See Notes Below

*See page 13 for an explanation of the load table icons

Shear Loads in Normal-Weight Concrete



Size in. (mm)	Drill Bit Dia. in.	Embed. Depth in. (mm)	Critical Edge Dist. in. (mm)	Critical Spacing Dist. in. (mm)	Shear Load						
					f _c ≥ 2000 psi (13.8 MPa) Concrete			f _c ≥ 3000 psi (20.7 MPa) Concrete	f _c ≥ 4000 psi (27.6 MPa) Concrete		
					Ultimate lbs. (kN)	Std. Dev. lbs. (kN)	Allowable lbs. (kN)	Allowable lbs. (kN)	Ultimate lbs. (kN)	Std. Dev. lbs. (kN)	Allowable lbs. (kN)
3/8 (9.5)	3/8	2 3/4 (70)	4 1/2 (114)	6 (152)	6,353 (28.3)	—	1,585 (7.1)	1,665 (7.4)	—	—	1,740 (7.7)
		3 3/4 (95)			6,377 (28.4)	1,006 (4.5)	1,595 (7.1)	1,670 (7.4)	—	—	1,740 (7.7)
1/2 (12.7)	1/2	2 3/4 (70)	6 (152)	8 (203)	6,435 (28.6)	—	1,605 (7.1)	2,050 (9.1)	9,987 (44.4)	—	2,495 (7.8)
		3 5/8 (92)			9,324 (41.5)	1,285 (5.7)	2,330 (10.4)	2,795 (12.4)	13,027 (57.9)	597 (2.7)	3,255 (14.5)
		5 3/4 (146)			11,319 (50.3)	1,245 (5.5)	2,830 (12.6)	3,045 (13.5)	—	—	3,255 (14.5)
5/8 (15.9)	5/8	2 3/4 (70)	7 1/2 (191)	10 (254)	7,745 (34.5)	—	1,940 (8.6)	2,220 (9.9)	9,987 (44.4)	—	2,495 (11.1)
		4 1/8 (105)			8,706 (38.7)	1,830 (8.1)	2,175 (9.7)	3,415 (15.2)	18,607 (82.8)	1,650 (7.3)	4,650 (20.7)
		5 3/4 (146)			12,498 (55.6)	2,227 (9.9)	3,125 (13.9)	3,890 (17.3)	—	—	4,650 (20.7)
3/4 (19.1)	3/4	2 3/4 (70)	9 (229)	12 (305)	7,832 (34.8)	—	1,960 (8.7)	2,415 (10.7)	11,460 (51.0)	—	2,865 (12.7)
		4 5/8 (117)			11,222 (49.9)	2,900 (12.9)	2,805 (12.5)	4,490 (20.0)	24,680 (109.8)	2,368 (10.5)	6,170 (27.4)
		5 3/4 (146)			19,793 (88.0)	3,547 (15.8)	4,950 (22.0)	5,560 (24.7)	24,680 (109.8)	795 (3.5)	6,170 (27.4)

1. The allowable loads listed are based on a safety factor of 4.0.

2. Refer to allowable load-adjustment factors for spacing and edge distance on pages 119–120.

3. The minimum concrete thickness is 1 1/2 times the embedment depth.

4. Tension and Shear loads for the Titen HD anchor may be combined using the elliptical interaction equation (n=3/4). Allowable load may be interpolated for concrete compressive strengths between 2000 psi and 4000 psi.

Titen HD® Heavy Duty Screw Anchor for Cracked and Uncracked Concrete

**Shear Loads in Normal-Weight Concrete,
Load Applied Parallel to Concrete Edge**

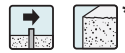

Size in. (mm)	Drill Bit Dia. in.	Embed. Depth in. (mm)	Minimum Edge Dist. in. (mm)	Minimum End Dist. in. (mm)	Minimum Spacing Dist. in. (mm)	Shear Load Based on Concrete Edge Distance		
						f _c ≥ 2500 psi (17.2 MPa) Concrete		
						Ultimate lbs. (kN)	Std. Dev. lbs. (kN)	Allowable lbs. (kN)
1/2 (12.7)	1/2	2 3/4 (70)	1 3/4 (45)	8 (203)	8 (203)	4,660 (20.7)	575 (2.6)	1,165 (5.2)
		3 1/4 (83)				—	1,530 (6.8)	
		3 1/2 (89)				6,840 (30.4)	860 (3.8)	1,710 (7.6)
		4 1/2 (114)				7,800 (34.7)	300 (1.3)	1,950 (8.7)
5/8 (15.9)	5/8	2 3/4 (70)	1 3/4 (45)	10 (254)	10 (254)	4,820 (21.4)	585 (2.6)	1,205 (5.3)
		3 1/4 (83)				—	1,580 (7.0)	
		3 1/2 (89)				7,060 (31.4)	1,284 (5.7)	1,765 (7.9)

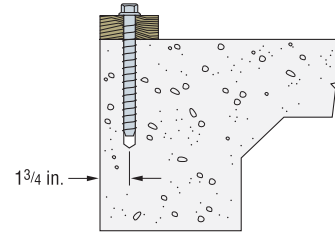

Note: Rebar not shown for clarity.

1. The allowable loads listed are based on a safety factor of 4.0.
2. The minimum concrete thickness is 1 1/2 times the embedment depth.

*See page 13 for an explanation of the load table icons

Mechanical Anchors

The Titen HD® screw anchor may be used for sill plate applications. Use bearing plates as required by code. Refer to the appropriate code report or use Simpson Strong-Tie ACI 318 Anchor Selector™ software for anchor design information.

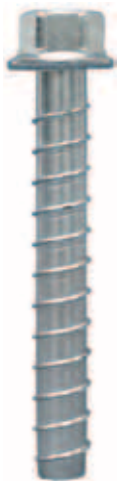

**Titen HD
Screw Anchor**
U.S. Patent
5,674,035 &
6,623,228

Titen HD® Heavy Duty Screw Anchor for Cracked and Uncracked Concrete

Tension Loads in Normal-Weight Concrete Stemwall

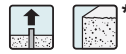

Size in. (mm)	Drill Bit Dia. in.	Embed. Depth in. (mm)	Stemwall Width in. (mm)	Min. Edge Dist. in. (mm)	Min. End Dist. in. (mm)	Tension Load			
						$f'_c \geq 2500$ psi (17.2 MPa) Concrete		$f'_c \geq 4500$ psi (31.0 MPa) Concrete	
						Ultimate lbs. (kN)	Allow. lbs. (kN)	Ultimate lbs. (kN)	Allow. lbs. (kN)
1/2 (12.7)	1/2	10 (254)	6 (152)	1 1/4 (44)	8 (203)	15,420 (68.6)	3,855 (17.1)	20,300 (90.3)	5,075 (22.6)
					4 3/8 (111)	14,280 (63.5)	3,570 (15.9)	19,040 (84.7)	4,760 (21.2)

- The allowable loads are based on a safety factor of 4.0.
- The minimum anchor spacing is 15 inches.
- The minimum concrete thickness (depth) is 12 inches.
- Allowable loads may be interpolated for compressive strengths between 2,500 and 4,500 psi.

Tension Loads in Normal-Weight Concrete, Load Applied at 60° Angle to Horizontal for Tilt-Up Wall Braces



Size in. (mm)	Drill Bit Dia. in.	Embed. Depth in. (mm)	Tension Applied at 60-degrees to Horizontal		
			$f'_c \geq 2500$ psi (17.2 MPa) Concrete		
			Ultimate lbs. (kN)	Std. Dev. lbs. (kN)	Allow. lbs. (kN)
5/8 (15.9)	5/8	5 (127)	13,420 (59.7)	1,273 (5.7)	3,355 (14.9)
3/4 (19.1)	3/4	5 (127)	15,180 (67.5)	968 (4.3)	3,795 (16.9)

- The allowable loads are based on a safety factor of 4.0.
- Anchor must be installed into a concrete floor slab, footing, or deadman with sufficient area, weight, and strength to resist the anchorage load.
- Titen HD® has been qualified for temporary outdoor use of up to 90 days through testing for this application.

Tension and Shear Loads in Sand-Lightweight Concrete over Metal Deck



Size in. (mm)	Drill Bit Dia. in.	Embed. Depth in. (mm)	Critical Edge Dist. in. (mm)	Critical Spacing Dist. in. (mm)	Install in Concrete (see Figure A)				Install through Metal Deck (see Figure A)			
					Tension Load		Shear Load		Tension Load		Shear Load	
					Ultimate lbs. (kN)	Allowable lbs. (kN)	Ultimate lbs. (kN)	Allowable lbs. (kN)	Ultimate lbs. (kN)	Allowable lbs. (kN)	Ultimate lbs. (kN)	Allowable lbs. (kN)
3/8 (9.5)	3/8	2 3/4 (70)	6 (152)	6 (152)	2,560 (11.4)	640 (2.8)	4,240 (18.9)	1,060 (4.7)	—	—	—	—
		3 (76)			—	—	—	5,420 (24.1)	1,355 (6.0)	4,100 (18.2)	1,025 (4.6)	
1/2 (12.7)	1/2	2 3/4 (70)	8 (203)	8 (203)	3,040 (13.5)	760 (3.4)	6,380 (28.4)	1,595 (7.1)	—	—	—	—
		4 (102)			—	—	—	7,020 (31.2)	1,755 (7.8)	6,840 (30.4)	1,710 (7.6)	
5/8 (15.9)	5/8	2 3/4 (70)	10 (254)	10 (254)	3,100 (13.8)	775 (3.4)	6,380 (28.4)	1,595 (7.1)	—	—	—	—
		5 (127)			—	—	—	8,940 (39.8)	2,235 (9.9)	10,700 (47.6)	2,675 (11.9)	

- The allowable loads listed are based on a safety factor of 4.0.
 - Allowable loads for anchors installed in the lower flute of the steel deck are for flutes with a trapezoidal profile with a depth of 3 inches, and a width varying from 4 1/2 inches at the bottom to 7 1/2 inches at the top. The spacing of the flutes is 12 inches. The metal deck must be minimum 20-gauge with a minimum yield strength of 38 ksi and minimum ultimate strength of 45 ksi.
 - Anchors may be installed off-center in the lower flute (up to 1 1/2" from the edge of the lower flute) without a load reduction.
 - 100% of the allowable load is permitted at critical edge distance and critical spacing. Testing at smaller edge distances and spacings has not been performed.
- *See page 13 for an explanation of the load table icons

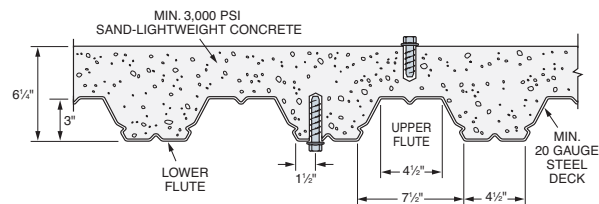

Figure A – Titen HD® screw anchor installed in the top and bottom of a structural sand-lightweight-concrete and metal-deck assembly

Titen HD® Heavy Duty Screw Anchor for Cracked and Uncracked Concrete

Tension and Shear Loads in 8-inch Lightweight, Medium-Weight and Normal-Weight Grout-Filled CMU



* See page 13 for an explanation of the load table icons

Size in. (mm)	Drill Bit Dia. in.	Min. Embed. Depth in. (mm)	Critical Edge Dist. in. (mm)	Critical End Dist. in. (mm)	Critical Spacing Dist. in. (mm)	Values for 8-inch Lightweight, Medium-Weight or Normal-Weight Grout-Filled CMU			
						Tension Load		Shear Load	
						Ultimate lbs. (kN)	Allowable lbs. (kN)	Ultimate lbs. (kN)	Allowable lbs. (kN)
Anchor Installed in the Face of the CMU Wall (See Figure 1)									
3/8 (9.5)	3/8	2 3/4 (70)	12 (305)	12 (305)	6 (152)	2,390 (10.6)	480 (2.1)	4,340 (19.3)	870 (3.9)
1/2 (12.7)	1/2	3 1/2 (89)	12 (305)	12 (305)	8 (203)	3,440 (15.3)	690 (3.1)	6,920 (30.8)	1,385 (6.2)
5/8 (15.9)	5/8	4 1/2 (114)	12 (305)	12 (305)	10 (254)	5,300 (23.6)	1,060 (4.7)	10,420 (46.4)	2,085 (9.3)
3/4 (19.1)	3/4	5 1/2 (140)	12 (305)	12 (305)	12 (305)	7,990 (35.5)	1,600 (7.1)	15,000 (66.7)	3,000 (13.3)

- The tabulated allowable loads are based on a safety factor of 5.0 for installations under the IBC and IRC.
- Values for 8-inch wide, lightweight, medium-weight and normal-weight concrete masonry units.
- The masonry units must be fully grouted.
- The minimum specified compressive strength of masonry, f_m , at 28 days is 1,500 psi.
- Embedment depth is measured from the outside face of the concrete masonry unit.
- Allowable loads may be increased 33 1/3% for short-term loading due to wind or seismic forces where permitted by code.
- Grout-filled CMU wall design must satisfy applicable design standards and be capable of withstanding applied loads.
- Refer to allowable load-adjustment factors for spacing and edge distance on page 121.

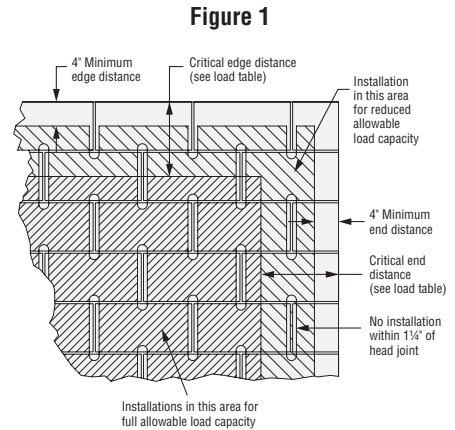

Shaded Area = Placement for Full and Reduced Allowable Load Capacity in Grout-Filled CMU

Tension and Shear Loads in 8-inch Lightweight, Medium-Weight and Normal-Weight Hollow CMU



Size in. (mm)	Drill Bit Dia. in.	Embed. Depth ⁴ in. (mm)	Min. Edge Dist. in. (mm)	Min. End Dist. in. (mm)	8-inch Hollow CMU Loads Based on CMU Strength			
					Tension Load		Shear Load	
					Ultimate lbs. (kN)	Allowable lbs. (kN)	Ultimate lbs. (kN)	Allowable lbs. (kN)
Anchor Installed in Face Shell (See Figure 2)								
3/8 (9.5)	3/8	1 3/4 (44)	4 (102)	4 5/8 (117)	720 (3.2)	145 (0.6)	1,240 (5.5)	250 (1.1)
1/2 (12.7)	1/2	1 3/4 (44)	4 (102)	4 5/8 (117)	760 (3.4)	150 (0.7)	1,240 (5.5)	250 (1.1)
5/8 (15.9)	5/8	1 3/4 (44)	4 (102)	4 5/8 (117)	800 (3.6)	160 (0.7)	1,240 (5.5)	250 (1.1)
3/4 (19.1)	3/4	1 3/4 (44)	4 (102)	4 5/8 (117)	880 (3.9)	175 (0.8)	1,240 (5.5)	250 (1.1)

- The tabulated allowable loads are based on a safety factor of 5.0 for installations under the IBC and IRC.
- Values for 8-inch wide, lightweight, medium-weight and normal-weight concrete masonry units.
- The minimum specified compressive strength of masonry, f_m , at 28 days is 1,500 psi.
- Embedment depth is measured from the outside face of the concrete masonry unit and is based on the anchor being embedded an additional 1/2" through 1 1/4" thick face shell.
- Allowable loads may not be increased for short-term loading due to wind or seismic forces. CMU wall design must satisfy applicable design standards and be capable of withstanding applied loads.
- Do not use impact wrenches to install in hollow CMU.
- Set drill to rotation-only mode when drilling into hollow CMU.

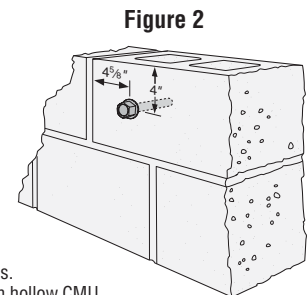

Figure 3

Tension and Shear Loads in 8-inch Lightweight, Medium-Weight and Normal-Weight Grout-Filled CMU Stemwall



Size in. (mm)	Drill Bit Dia. in.	Embed. Depth in. (mm)	Min. Edge Dist. in. (mm)	Min. End Dist. in. (mm)	Critical Spacing Dist. in. (mm)	8-inch Grout-Filled CMU Allowable Loads Based on CMU Strength					
						Tension		Shear Perp. to Edge		Shear Parallel to Edge	
						Ultimate lbs. (kN)	Allowable lbs. (kN)	Ultimate lbs. (kN)	Allowable lbs. (kN)	Ultimate lbs. (kN)	Allowable lbs. (kN)
Anchor Installed in Cell Opening or Web (Top of Wall) (See Figure 3)											
1/2 (12.7)	1/2	4 1/2 (114)	1 3/4 (44.5)	8 (203)	8 (203)	2,860 (12.7)	570 (2.5)	800 (3.6)	160 (0.7)	2,920 (13.0)	585 (2.6)
5/8 (15.9)	5/8	4 1/2 (114)	1 3/4 (44.5)	10 (254)	10 (254)	2,860 (12.7)	570 (2.5)	800 (3.6)	160 (0.7)	3,380 (15.0)	675 (3.0)

- The tabulated allowable loads are based on a safety factor of 5.0 for installations under the IBC and IRC.
- Values are for 8-inch wide, lightweight, medium-weight and normal-weight concrete masonry units.
- The masonry units must be fully grouted.
- The minimum specified compressive strength of masonry, f_m , at 28 days is 1,500 psi.
- Allowable loads may be increased 33 1/3% for short-term loading due to wind or seismic forces where permitted by code.
- Grout-filled CMU wall design must satisfy applicable design standards and be capable of withstanding applied design loads.
- Loads are based on anchor installed in either the web or grout-filled cell opening in the top of wall.

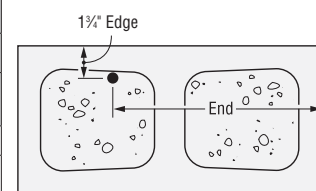

Anchor installed in top of wall

Titen HD® Technical Information

**Load-Adjustment Factors for Titen HD® Anchors in Normal-Weight Concrete:
Edge Distance, Tension and Shear Loads**



These tables are not for use with SD design methods

How to use these charts:

1. The following tables are for reduced edge distance.
2. Locate the anchor size to be used for either a tension and/or shear load application.
3. Locate the anchor embedment (E) used for either a tension and/or shear load application.
4. Locate the edge distance (C_{act}) at which the anchor is to be installed.
5. The load adjustment factor (f_c) is the intersection of the row and column.
6. Multiply the allowable load by the applicable load adjustment factor(s).
7. Reduction factors for multiple edges are multiplied together.

Edge Distance Tension (f_c)



Edge Dist. C_{act} (in.)	Dia.	$\frac{3}{8}$			$\frac{1}{2}$			$\frac{5}{8}$			$\frac{3}{4}$		
	E	2 3/4	3 3/4	2 3/4	3 3/8	5 3/4	2 3/4	4 3/8	5 3/4	2 3/4	4 3/8	5 3/4	
	C_{cr}	3	3	4	4	4	5	5	5	6	6	6	
	C_{min}	1 3/4	1 3/4	1 3/4	1 3/4	1 3/4	1 3/4	1 3/4	1 3/4	1 3/4	1 3/4	1 3/4	
	f_{cmin}	0.83	0.73	0.67	0.57	0.73	0.67	0.57	0.59	0.67	0.48	0.58	
1 3/4		0.83	0.73	0.67	0.57	0.73	0.67	0.57	0.59	0.67	0.48	0.58	
2		0.86	0.78	0.71	0.62	0.76	0.70	0.60	0.62	0.69	0.51	0.60	
2 1/4		0.90	0.84	0.74	0.67	0.79	0.72	0.64	0.65	0.71	0.54	0.63	
2 1/2		0.93	0.89	0.78	0.71	0.82	0.75	0.67	0.68	0.73	0.57	0.65	
2 3/4		0.97	0.95	0.82	0.76	0.85	0.77	0.70	0.72	0.75	0.60	0.68	
3		1.00	1.00	0.85	0.81	0.88	0.80	0.74	0.75	0.77	0.63	0.70	
3 1/4				0.89	0.86	0.91	0.82	0.77	0.78	0.79	0.66	0.73	
3 1/2				0.93	0.90	0.94	0.85	0.80	0.81	0.81	0.69	0.75	
3 3/4				0.96	0.95	0.97	0.87	0.83	0.84	0.83	0.72	0.78	
4				1.00	1.00	1.00	0.90	0.87	0.87	0.84	0.76	0.80	
4 1/4							0.92	0.90	0.91	0.86	0.79	0.83	
4 1/2							0.95	0.93	0.94	0.88	0.82	0.85	
4 3/4							0.97	0.97	0.97	0.90	0.85	0.88	
5							1.00	1.00	1.00	0.92	0.88	0.90	
5 1/4										0.94	0.91	0.93	
5 1/2										0.96	0.94	0.95	
5 3/4										0.98	0.97	0.98	
6										1.00	1.00	1.00	

*See page 13 for an explanation of the load table icons

See Notes Below

Edge Distance Shear (f_c)



Edge Dist. C_{act} (in.)	Dia.	$\frac{3}{8}$			$\frac{1}{2}$			$\frac{5}{8}$			$\frac{3}{4}$		
	E	2 3/4	3 3/4	2 3/4	3 3/8	5 3/4	2 3/4	4 3/8	5 3/4	2 3/4	4 3/8	5 3/4	
	C_{cr}	4 1/2	4 1/2	6	6	6	7 1/2	7 1/2	7 1/2	9	9	9	
	C_{min}	1 3/4	1 3/4	1 3/4	1 3/4	1 3/4	1 3/4	1 3/4	1 3/4	1 3/4	1 3/4	1 3/4	
	f_{cmin}	0.25	0.24	0.25	0.20	0.17	0.19	0.16	0.19	0.19	0.14	0.13	
1 3/4		0.25	0.24	0.25	0.20	0.17	0.19	0.16	0.19	0.19	0.14	0.13	
2		0.32	0.31	0.29	0.25	0.22	0.23	0.20	0.23	0.22	0.17	0.16	
2 1/2		0.45	0.45	0.38	0.34	0.32	0.30	0.27	0.30	0.27	0.23	0.22	
3		0.59	0.59	0.47	0.44	0.41	0.37	0.34	0.37	0.33	0.29	0.28	
3 1/2		0.73	0.72	0.56	0.53	0.51	0.44	0.42	0.44	0.39	0.35	0.34	
4		0.86	0.86	0.65	0.62	0.61	0.51	0.49	0.51	0.44	0.41	0.40	
4 1/2		1.00	1.00	0.74	0.72	0.71	0.58	0.56	0.58	0.50	0.47	0.46	
5				0.82	0.81	0.80	0.65	0.63	0.65	0.55	0.53	0.52	
5 1/2				0.91	0.91	0.90	0.72	0.71	0.72	0.61	0.58	0.58	
6				1.00	1.00	1.00	0.79	0.78	0.79	0.66	0.64	0.64	
6 1/2							0.86	0.85	0.86	0.72	0.70	0.70	
7							0.93	0.93	0.93	0.78	0.76	0.76	
7 1/2							1.00	1.00	1.00	0.83	0.82	0.82	
8										0.89	0.88	0.88	
8 1/2										0.94	0.94	0.94	
9										1.00	1.00	1.00	

The tabled adjustment values (f_c) have been calculated using the following information:

1. E = Embedment depth (inches).
2. C_{act} = actual edge distance at which anchor is installed (inches).
3. C_{cr} = critical edge distance for 100% load (inches).
4. C_{min} = minimum edge distance for reduced load (inches).
5. f_c = percent of allowable load at actual edge distance.
6. f_{ccr} = percentage of allowable load at critical edge distance. f_{ccr} is always = 1.00.
7. f_{cmin} = percent of allowable load at minimum edge distance.
8. $f_c = f_{cmin} + [(1 - f_{cmin}) / (C_{cr} - C_{min})] \cdot (C_{act} - C_{min})$.

Titen HD® Technical Information

Load-Adjustment Factors for Titen HD® Anchors in Normal-Weight Concrete: Spacing, Tension and Shear Loads



These tables are not for use with SD design methods

How to use these charts:

1. The following tables are for reduced spacing.
2. Locate the anchor size to be used for either a tension and/or shear load application.
3. Locate the anchor embedment (E) used for either a tension and/or shear load application.
4. Locate the spacing (S_{act}) at which the anchor is to be installed.
5. The load adjustment factor (f_s) is the intersection of the row and column.
6. Multiply the allowable load by the applicable load adjustment factor(s).
7. Reduction factors for multiple spacings are multiplied together.

Spacing Tension (f_s)



S_{act} (in.)	Dia.	$\frac{3}{8}$			$\frac{1}{2}$			$\frac{5}{8}$			$\frac{3}{4}$		
	E	2¼	3¾	2¼	3¾	5¼	2¼	4¼	5¼	2¼	4¾	5¼	
	S_{cr}	6	6	8	8	8	10	10	10	12	12	12	
	S_{min}	1½	1½	2	2	2	2½	2½	2½	3	3	3	
	f_{smin}	0.66	0.56	0.72	0.63	0.76	0.79	0.69	0.73	0.80	0.70	0.72	
1½		0.66	0.56										
2		0.70	0.61	0.72	0.63	0.76							
2½		0.74	0.66	0.74	0.66	0.78	0.79	0.69	0.73				
3		0.77	0.71	0.77	0.69	0.80	0.80	0.71	0.75	0.80	0.70	0.72	
4		0.85	0.80	0.81	0.75	0.84	0.83	0.75	0.78	0.82	0.73	0.75	
5		0.92	0.90	0.86	0.82	0.88	0.86	0.79	0.82	0.84	0.77	0.78	
6		1.00	1.00	0.91	0.88	0.92	0.89	0.83	0.86	0.87	0.80	0.81	
7				0.95	0.94	0.96	0.92	0.88	0.89	0.89	0.83	0.84	
8				1.00	1.00	1.00	0.94	0.92	0.93	0.91	0.87	0.88	
9							0.97	0.96	0.96	0.93	0.90	0.91	
10							1.00	1.00	1.00	0.96	0.93	0.94	
11										0.98	0.97	0.97	
12										1.00	1.00	1.00	

*See page 13 for an explanation of the load table icons

See Notes Below

Spacing Shear (f_s)



S_{act} (in.)	Dia.	$\frac{3}{8}$			$\frac{1}{2}$			$\frac{5}{8}$			$\frac{3}{4}$		
	E	2¼	3¾	2¼	3¾	5¼	2¼	4¼	5¼	2¼	4¾	5¼	
	S_{cr}	6	6	8	8	8	10	10	10	12	12	12	
	S_{min}	1½	1½	2	2	2	2½	2½	2½	3	3	3	
	f_{smin}	0.77	0.77	0.77	0.77	0.77	0.77	0.77	0.77	0.77	0.77	0.77	
1½		0.77	0.77										
2		0.80	0.80	0.77	0.77	0.77							
2½		0.82	0.82	0.79	0.79	0.79	0.77	0.77	0.77				
3		0.85	0.85	0.81	0.81	0.81	0.79	0.79	0.79	0.77	0.77	0.77	
4		0.90	0.90	0.85	0.85	0.85	0.82	0.82	0.82	0.80	0.80	0.80	
5		0.95	0.95	0.89	0.89	0.89	0.85	0.85	0.85	0.82	0.82	0.82	
6		1.00	1.00	0.92	0.92	0.92	0.88	0.88	0.88	0.85	0.85	0.85	
7				0.96	0.96	0.96	0.91	0.91	0.91	0.87	0.87	0.87	
8				1.00	1.00	1.00	0.94	0.94	0.94	0.90	0.90	0.90	
9							0.97	0.97	0.97	0.92	0.92	0.92	
10							1.00	1.00	1.00	0.95	0.95	0.95	
11										0.97	0.97	0.97	
12										1.00	1.00	1.00	

The tabled adjustment values (f_s) have been calculated using the following information:

1. E = Embedment depth (inches).
2. S_{act} = actual spacing distance at which anchors are installed (inches).
3. S_{cr} = critical spacing distance for 100% load (inches).
4. S_{min} = minimum spacing distance for reduced load (inches).
5. f_s = adjustment factor for allowable load at actual spacing distance.
6. f_{scr} = adjustment factor for allowable load at critical spacing distance. f_{scr} is always = 1.00.
7. f_{smin} = adjustment factor for allowable load at minimum spacing distance.
8. $f_s = f_{smin} + [(1 - f_{smin}) \cdot (S_{act} - S_{min}) / (S_{cr} - S_{min})]$.

Titen HD® Technical Information

Load-Adjustment Factors for Titen HD® Anchors in Face-of-Wall Installation in 8" Grout-Filled CMU: Edge Distance and Spacing, Tension and Shear Loads



These tables are not for use with SD design methods

How to use these charts:

1. The following tables are for reduced edge distance and spacing.
2. Locate the anchor size to be used for either a tension and/or shear load application.
3. Locate the embedment (E) at which the anchor is to be installed.
4. Locate the edge distance (C_{act}) or spacing (S_{act}) at which the anchor is to be installed.
5. The load adjustment factor (f_c or f_s) is the intersection of the row and column.
6. Multiply the allowable load by the applicable load adjustment factor.
7. Reduction factors for multiple edges or spacings are multiplied together.

Edge or End Distance Tension (f_c)



C_{act} (in.)	Dia.	3/8	1/2	5/8	3/4
	E	2 3/4	3 1/2	4 1/2	5 1/2
	C_{cr}	12	12	12	12
	C_{min}	4	4	4	4
	f_{cmin}	1.00	1.00	0.83	0.66
4		1.00	1.00	0.83	0.66
6		1.00	1.00	0.87	0.75
8		1.00	1.00	0.92	0.83
10		1.00	1.00	0.96	0.92
12		1.00	1.00	1.00	1.00

See Notes Below

Edge and End Distance Shear (f_c) Shear Load Parallel to Edge or End



C_{act} (in.)	Dia.	3/8	1/2	5/8	3/4
	E	2 3/4	3 1/2	4 1/2	5 1/2
	C_{cr}	12	12	12	12
	C_{min}	4	4	4	4
	f_{cmin}	0.77	0.48	0.46	0.44
4		0.77	0.48	0.46	0.44
6		0.83	0.61	0.60	0.58
8		0.89	0.74	0.73	0.72
10		0.94	0.87	0.87	0.86
12		1.00	1.00	1.00	1.00

See Notes Below

Edge or End Distance Shear (f_c) Shear Load Perpendicular to Edge or End (Directed Towards Edge or End)



C_{act} (in.)	Dia.	3/8	1/2	5/8	3/4
	E	2 3/4	3 1/2	4 1/2	5 1/2
	C_{cr}	12	12	12	12
	C_{min}	4	4	4	4
	f_{cmin}	0.58	0.38	0.30	0.21
4		0.58	0.38	0.30	0.21
6		0.69	0.54	0.48	0.41
8		0.79	0.69	0.65	0.61
10		0.90	0.85	0.83	0.80
12		1.00	1.00	1.00	1.00

1. E = Embedment depth (inches).
2. C_{act} = actual end or edge distance at which anchor is installed (inches).
3. C_{cr} = critical end or edge distance for 100% load (inches).
4. C_{min} = minimum end or edge distance for reduced load (inches).
5. f_c = adjustment factor for allowable load at actual end or edge distance.
6. f_{ccr} = adjustment factor for allowable load at critical end or edge distance. f_{ccr} is always = 1.00.
7. f_{cmin} = adjustment factor for allowable load at minimum end or edge distance.
8. $f_c = f_{cmin} + [(1 - f_{cmin})(C_{act} - C_{min}) / (C_{cr} - C_{min})]$.

Edge or End Distance Shear (f_c) Shear Load Perpendicular to Edge or End (Directed Away From Edge or End)



C_{act} (in.)	Dia.	3/8	1/2	5/8	3/4
	E	2 3/4	3 1/2	4 1/2	5 1/2
	C_{cr}	12	12	12	12
	C_{min}	4	4	4	4
	f_{cmin}	0.89	0.79	0.58	0.38
4		0.89	0.79	0.58	0.38
6		0.92	0.84	0.69	0.54
8		0.95	0.90	0.79	0.69
10		0.97	0.95	0.90	0.85
12		1.00	1.00	1.00	1.00

*See page 13 for an explanation of the load table icons

Spacing Tension (f_s)



S_{act} (in.)	Dia.	3/8	1/2	5/8	3/4
	E	2 3/4	3 1/2	4 1/2	5 1/2
	S_{cr}	6	8	10	12
	S_{min}	3	4	5	6
	f_{smin}	0.87	0.69	0.59	0.50
3		0.87			
4		0.91	0.69		
5		0.96	0.77	0.59	
6		1.00	0.85	0.67	0.50
8			1.00	0.84	0.67
10				1.00	0.83
12					1.00

1. E = Embedment depth (inches).
2. S_{act} = actual spacing distance at which anchors are installed (inches).
3. S_{cr} = critical spacing distance for 100% load (inches).
4. S_{min} = minimum spacing distance for reduced load (inches).
5. f_s = adjustment factor for allowable load at actual spacing distance.
6. f_{scr} = adjustment factor for allowable load at critical spacing distance. f_{scr} is always = 1.00.
7. f_{smin} = adjustment factor for allowable load at minimum spacing distance.
8. $f_s = f_{smin} + [(1 - f_{smin})(S_{act} - S_{min}) / (S_{cr} - S_{min})]$.

Spacing Shear (f_s)



S_{act} (in.)	Dia.	3/8	1/2	5/8	3/4
	E	2 3/4	3 1/2	4 1/2	5 1/2
	S_{cr}	6	8	10	12
	S_{min}	3	4	5	6
	f_{smin}	0.62	0.62	0.62	0.62
3		0.62			
4		0.75	0.62		
5		0.87	0.72	0.62	
6		1.00	0.81	0.70	0.62
8			1.00	0.85	0.75
10				1.00	0.87
12					1.00

Titen HD® Mini Screw Anchor for Concrete and Masonry

Sharing the same features as the larger Titen HD® screw anchor (page 110), the Titen HD® Mini anchor provides an easy solution for jobs that call for smaller anchors. The self-undercutting, non-expansion characteristics are ideal for situations where minimum edge distance and reduced spacing is a concern. The patented cutting teeth and thread design enable the Titen HD Mini anchor to be installed quickly and with less effort than many other screw type anchors. Since there are no secondary setting steps involved, the Titen HD Mini screw anchor can be installed much more quickly than traditional expansion anchors.

FEATURES:

- Full-length threads undercut the concrete and effectively transfer loads into the base material.
- Specialized heat-treating process creates high hardness at the tip to facilitate cutting while the body remains ductile.
- Less spacing and edge distance required since the anchor does not exert expansion forces
- No special installation tools required. Holes can be drilled with rotary hammer or hammer drill with ANSI size bit. Anchors are installed with standard size sockets.
- Less installation time translates to lower installed cost.
- Removable, ideal for temporary anchorage.

MATERIAL: Carbon steel, heat treated

FINISH: Zinc plated

TEST CRITERIA: The Titen HD® Mini anchor has been tested in accordance with ASTM E488 standard test methods for tension and shear.

INSTALLATION:

-  Caution: Oversized holes in the base material will reduce or eliminate the mechanical interlock of the threads with base material and will reduce the anchor's load capacity. Use a Titen HD Mini screw anchor one time only. Installing the anchor multiple times may result in excessive thread wear and reduce load capacity.
- Drill a hole using the specified diameter carbide bit into the base material to a depth of at least 1/2" deeper than the required embedment depth.
 - Blow the hole clean of dust and debris using compressed air.
 - Insert the anchor through the fixture and into the hole.
 - **IMPORTANT:** In normal-weight concrete, install with an applied torque of 15 ft-lbs for the 1/4" Titen HD Mini and 25 ft-lbs for the 3/8" Titen HD Mini using a torque wrench, driver drill, hammer drill or cordless 1/4" impact driver with a maximum permitted torque rating of 100 ft-lbs. In hollow CMU, do not use impact tools to install and use a manual applied torque of 10 ft-lbs.



U.S. Patent
5,674,035 & 6,623,228

Installation Sequence

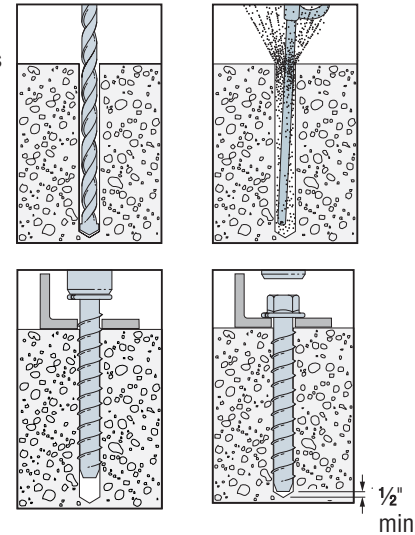

Titen HD® Mini Anchor Product Data

Size	Model No.	Drill Bit Dia (in.)	Wrench Size (in.)	Recommended Fixture Hole Size (in.)	Quantity	
					Box	Ctn.
1/4" x 1 3/4"	THD25134H	1/4	3/8	5/16 - 3/8	100	500
1/4" x 2 1/4"	THD25214H	1/4	3/8	5/16 - 3/8	50	250
1/4" x 3"	THD25300H	1/4	3/8	5/16 - 3/8	50	250
3/8" x 1 3/4"	THD37134H	3/8	9/16	1/2 - 9/16	50	250
3/8" x 2 1/2"	THD37212H	3/8	9/16	1/2 - 9/16	50	200

Tension Loads in Normal-Weight Concrete

Size in. (mm)	Drill Bit Dia. in.	Embed. Depth in. (mm)	Min. Spacing in. (mm)	Min. Edge Dist. in. (mm)	Tension Load			
					f'c ≥ 2000 psi Concrete		f'c ≥ 4000 psi Concrete	
					Ultimate lbs. (kN)	Allowable lbs. (kN)	Ultimate lbs. (kN)	Allowable lbs. (kN)
1/4 (6.4)	1/4	1 (25)	4 (102)	4 (102)	624 (2.8)	155 (0.7)	1,037 (4.6)	260 (1.2)
		1 3/4 (44)			1,768 (7.9)	440 (2.0)	2,255 (10.0)	565 (2.5)
3/8 (9.5)	3/8	1 1/2 (38)	4 (102)	6 (152)	2,070 (9.2)	520 (2.3)	2,974 (13.2)	745 (3.3)

See Notes Below



* See page 13 for an explanation of the load table icons

Shear Loads in Normal-Weight Concrete

Size in. (mm)	Drill Bit Dia. in.	Embed. Depth in. (mm)	Min. Spacing in. (mm)	Min. Edge Dist. in. (mm)	Shear Load			
					f'c ≥ 2000 psi Concrete		f'c ≥ 4000 psi Concrete	
					Ultimate lbs. (kN)	Allowable lbs. (kN)	Ultimate lbs. (kN)	Allowable lbs. (kN)
1/4 (6.4)	1/4	1 (25)	4 (102)	4 (102)	1,104 (4.9)	275 (1.2)	2,135 (9.5)	535 (2.4)
		1 3/4 (44)			2,443 (10.9)	610 (2.7)	—	610 (2.7)
3/8 (9.5)	3/8	1 1/2 (38)	4 (102)	6 (152)	2,912 (13.0)	730 (3.2)	3,668 (16.3)	915 (4.1)

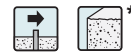

1. The allowable loads are based on a safety factor of 4.0.
2. The minimum concrete thickness is 1 1/2 times the embedment depth.
3. Tension and Shear loads may be combined using the straight line interaction equation (n=1).

Tension and Shear Loads in 8-inch Lightweight, Medium-Weight and Normal-Weight Hollow CMU

Size in. (mm)	Drill Bit Dia. in.	Embed. Depth ⁴ in. (mm)	Min. Edge Dist. in. (mm)	Min. End Dist. in. (mm)	8-inch Hollow CMU Loads Based on CMU Strength			
					Tension Load		Shear Load	
					Ultimate lbs. (kN)	Allowable lbs. (kN)	Ultimate lbs. (kN)	Allowable lbs. (kN)
Anchor Installed in Face Shell (See Figure 1)								
1/4 (6.4)	1/4	1 1/2 (38)	4 (102)	4% (117)	520 (2.3)	105 (0.5)	1,240 (5.5)	250 (1.1)
3/8 (9.5)	3/8	1 1/2 (38)	4 (102)	4% (117)	720 (3.2)	145 (0.6)	1,240 (5.5)	250 (1.1)

1. The tabulated allowable loads are based on a safety factor of 5.0 for installations under the IBC and IRC.
2. Values for 8-inch wide, lightweight, medium-weight, and normal-weight CMU.
3. The minimum specified compressive strength of masonry, f'c, at 28 days is 1,500 psi.

4. Embedment depth is measured from the outside face of the concrete masonry unit and is based on the anchor being embedded an additional 1/4" through the 1 1/4" thick face shell.
5. Allowable loads may not be increased for short-term loading due to wind or seismic forces. CMU wall design must satisfy applicable design standards and be capable of withstanding applied loads.
6. Set drill to rotation-only mode when drilling into hollow CMU.
7. Do not use impact wrenches to install in hollow CMU.



Titen HD® Threaded Rod Hanger for Cracked and Uncracked Concrete

The Titen HD® rod hanger is a high-strength screw anchor designed to suspend threaded rod from concrete slabs and beams in order to hang pipes, cable tray and HVAC equipment. This anchor is code listed by ICC-ES for cracked and uncracked concrete applications under the 2009 IBC.

FEATURES:

- High-load capacity as a result of the full-length threads that undercut the concrete and effectively transfer load into the base material
- Specialized heat-treating process creates greater hardness at the tip to facilitate cutting while the body remains ductile
- Serrated cutting teeth and patented thread design enable quick and easy installation
- No special installation tools required. Holes can be drilled with a rotary hammer or hammer drill with standard ANSI-size bit. Anchors are installed with standard-size sockets.

MATERIAL: Carbon steel, heat treated

FINISH: Zinc plated

INSTALLATION:

- ⚠ **Caution:** Oversized holes in the base material will reduce or eliminate the mechanical interlock of the threads with base material and will reduce the anchor's load capacity. Use a Titen HD® Rod Hanger one time only. Installing the anchor multiple times may result in excessive thread wear and reduce load capacity
- Drill a hole using the specified diameter carbide bit into the base material to a depth of at least ½" deeper than the required embedment.
- Blow the hole clean of dust and debris using compressed air.
- **IMPORTANT:** Install with an applied torque of 15 ft-lbs for the THD25112RH and THD37218RH rod hangers using a torque wrench, driver drill, hammer drill or cordless ¼" impact driver with a maximum permitted torque rating of 100 ft-lb.

CODES: ICC-ES ESR-2713 (THD37212RH and THD50234RH), Factory Mutual 3031136 (THD50234RH and THD37218RH) and 3035761 (THD37212RH)

U.S. Patent
5,674,035 & 6,623,228

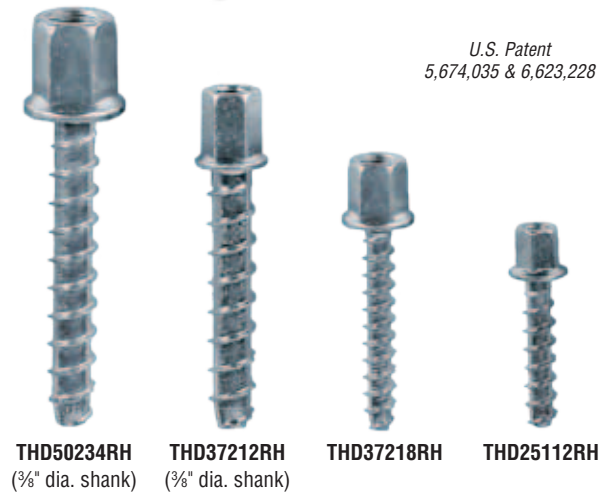

Mechanical Anchors

Titen HD® Rod Hanger Product Data

Size (in.)	Model No.	Accepts Rod Dia. (in.)	Drill Bit Dia. (in.)	Wrench Size (in.)	Min. Embed. (in.)	Quantity	
						Box	Carton
¼ x 1½	THD25112RH	¼	¼	¾	1½	100	500
¾ x 2¾	THD37218RH	¾	¼	½	2¾	50	250
¾ x 2½	THD37212RH	¾	¾	½	2½	50	200
½ x 2¾	THD50234RH	½	¾	1¼	2¾	50	100

Installation Sequence

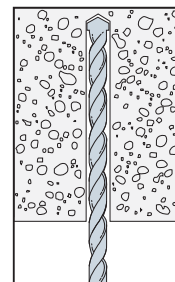

1. Drill a hole using the specified diameter carbide bit into the base material to a depth of at least ½" deeper than the required embedment.

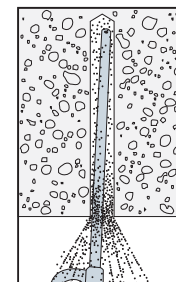

2. Blow the hole clean of dust and debris using compressed air.

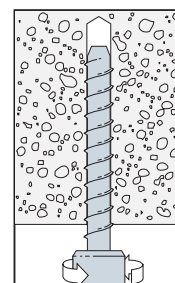

3. Insert anchor into the hole. Tighten the anchor with an impact wrench or a torque wrench into the base material until the hex washer head contacts the base material.

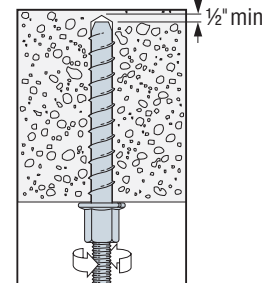
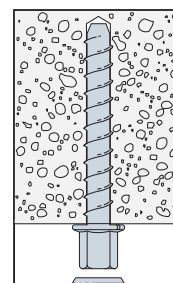

4. Install threaded rod in the anchor to support pipes, wiring, etc.

Titen HD® Threaded Rod Hanger for Cracked and Uncracked Concrete

Titen HD® Rod Hanger Installation Information and Additional Data¹

Characteristic	Symbol	Units	Model Number	
			THD37212RH	THD50234RH
Installation Information				
Rod Hanger Diameter	d_o	in.	$\frac{3}{8}$	$\frac{1}{2}$
Drill Bit Diameter	d_{bit}	in.	$\frac{3}{8}$	$\frac{3}{8}$
Maximum Installation Torque ²	$T_{inst,max}$	ft-lbf	50	50
Maximum Impact Wrench Torque Rating ³	$T_{impact,max}$	ft-lbf	150	150
Minimum Hole Depth	h_{hole}	in.	3	$3\frac{1}{4}$
Embedment Depth	h_{nom}	in.	$2\frac{1}{2}$	$2\frac{3}{4}$
Effective Embedment Depth	h_{ef}	in.	1.77	1.77
Critical Edge Distance	c_{ac}	in.	$2\frac{1}{16}$	$2\frac{1}{16}$
Minimum Edge Distance	c_{min}	in.	$1\frac{3}{4}$	
Minimum Spacing	s_{min}	in.	3	
Minimum Concrete Thickness	h_{min}	in.	$4\frac{1}{4}$	$4\frac{1}{4}$
Anchor Data				
Yield Strength	f_{ya}	psi	97,000	
Tensile Strength	f_{uta}	psi	110,000	
Minimum Tensile and Shear Stress Area	A_{se}	in ²	0.099	0.099
Axial Stiffness in Service Load Range – Uncracked Concrete	β_{uncr}	lb/in.	715,000	
Axial Stiffness in Service Load Range – Cracked Concrete	β_{cr}	lb/in.	345,000	

1. The information presented in this table is to be used in conjunction with the design criteria of ACI 318 Appendix D.
2. $T_{inst,max}$ is the maximum permitted installation torque for installations using a torque wrench.
3. $T_{impact,max}$ is the maximum permitted torque rating for impact wrenches.

Titen HD® Threaded Rod Hanger for Cracked and Uncracked Concrete

Strength Design Values for Titen HD® Rod Hanger in Tension for Installations in Concrete^{1,6}

*See page 13 for an explanation of the load table icons

Characteristic	Symbol	Units	Model Number	
			THD37212RH	THD50234RH
Anchor Category	1, 2 or 3	—	1	
Embedment Depth	h_{nom}	in.	2½	2¾
Steel Strength in Tension (ACI 318 Section D.5.1)				
Tension Resistance of Steel	N_{sa}	lb.	10,890	10,890
Strength Reduction Factor – Steel Failure ²	ϕ	—	0.65	
Concrete Breakout Strength in Tension (ACI 318 Section D.5.2)³				
Effective Embedment Depth	h_{ef}	in.	1.77	1.77
Critical Edge Distance	c_{ac}	in.	2¼	2¼
Effectiveness Factor – Uncracked Concrete	k_{uncr}	—	24	
Effectiveness Factor – Cracked Concrete	k_{cr}	—	17	
Modification Factor	$\psi_{c,N}$	—	1.0	
Strength Reduction Factor – Concrete Breakout Failure ⁵	ϕ	—	0.65	
Pullout Strength in Tension (ACI 318 Section D.5.3)⁶				
Pullout Resistance – Uncracked Concrete ($f'_c = 2500$ psi)	$N_{p,uncr}$	lb.	2,025 ³	2,025 ³
Pullout Resistance – Cracked Concrete ($f'_c = 2500$ psi)	$N_{p,cr}$	lb.	1,235 ³	1,235 ³
Strength Reduction Factor – Pullout Failure ⁴	ϕ	—	0.65	
Tension Strength for Seismic Applications (ACI 318 Section D.3.3.3)⁶				
Nominal Pullout Strength for Seismic Loads ($f'_c = 2500$ psi)	$N_{p,eq}$	lb.	1,235 ³	1,235 ³
Strength Reduction Factor – Pullout Failure ⁴	ϕ	—	0.65	

- The information presented in this table is to be used in conjunction with the design criteria of ACI 318 Appendix D, except as modified below.
- The value of ϕ applies when the load combinations of ACI 318 Section 9.2 are used. If the load combinations of ACI 318 Appendix C are used, refer to Section D.4.5 to determine the appropriate value of ϕ . Anchors are considered brittle steel elements.
- Adjust the characteristic pullout resistance for other concrete compressive strengths by multiplying the tabular value by $(f'_{c,specified}/2500)^{0.5}$.
- The value of ϕ applies when both the load combinations of ACI 318 Section 9.2 are used and the requirements of Section D.4.4(c) for Condition B are met. If the load combinations of ACI 318 Appendix C are used, refer to Section D.4.5 to determine the appropriate value of ϕ .

- The value of ϕ applies when both the load combinations of ACI 318 Section 9.2 are used and the requirements of Section D.4.4(c) for Condition B are met. If the load combinations of ACI 318 Section 9.2 are used and the requirements of Section D.4.4(c) for Condition A are met, refer to Section D.4.4 to determine the appropriate value of ϕ . If the load combinations of ACI 318 Appendix C are used, refer to Section D.4.5 to determine the appropriate value of ϕ .
- For sand-lightweight concrete, the modification factor for concrete breakout strength must be taken as 0.6. Additionally, the pullout strength $N_{p,uncr}$, $N_{p,cr}$ and $N_{p,eq}$ must be multiplied by 0.6, as applicable.
- For sand-lightweight concrete, in lieu of ACI 318 Section D.3.4, modify the value of concrete breakout strength, $N_{p,cr}$, $N_{p,uncr}$ and $N_{p,eq}$ by 0.6. All-lightweight concrete is beyond the scope of this table.

Titen HD® Threaded Rod Hanger for Cracked and Uncracked Concrete

Strength Design Values for Titen HD® Rod Hanger in Tension for Installations in the Lower and Upper Flute of Normal-Weight or Sand-Lightweight Concrete through Metal Deck^{1,2,5,6}



* See page 13 for an explanation of the load table icons

Characteristic	Symbol	Units	Catalog Number	
			THD37212RH	THD50234RH
Minimum Hole Depth	h_{hole}	in.	3	3¼
Embedment Depth	h_{nom}	in.	2½	2¾
Effective Embedment Depth	h_{ef}	in.	1.77	1.77
Pullout Resistance – Cracked Concrete ^{2,3,4}	$N_{p,deck,cr}$	lbf	870	870
Pullout Resistance – Uncracked Concrete ^{2,3,4}	$N_{p,deck,uncr}$	lbf	1,430	1,430

- The information presented in this table is to be used in conjunction with the design criteria of ACI 318 Appendix D, except as modified below.
- Concrete compressive strength shall be 3000 psi minimum. The characteristic pullout resistance for greater compressive strengths shall be increased by multiplying the tabular value by $(f'_{c, specified} / 3000 \text{ psi})^{0.5}$.
- For anchors installed in the soffit of sand-lightweight or normal-weight concrete over metal deck floor and roof assemblies, as shown in Figure A, calculation of the concrete breakout strength may be omitted.
- In accordance with ACI 318 Section D.5.3.2, the nominal pullout strength in cracked concrete for anchors installed in the soffit of sand-lightweight or normal-weight-concrete-over-metal-deck floor and roof assemblies $N_{p,deck,cr}$ shall be substituted for $N_{p,cr}$. Where analysis indicates no cracking at service loads, the normal pullout strength in uncracked concrete $N_{p,deck,uncr}$ shall be substituted for $N_{p,uncr}$.
- Minimum distance to edge of panel is $2h_{ef}$.
- The minimum anchor spacing along the flute must be the greater of $3h_{ef}$ or 1.5 times the flute width.

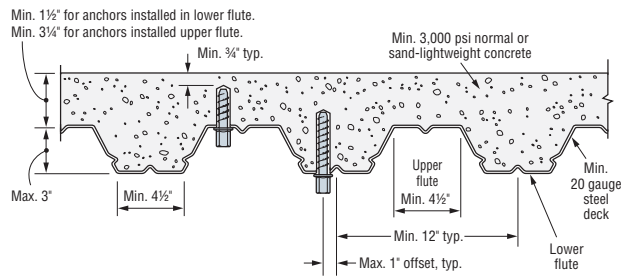

Figure A – Installation in Concrete Over Metal Deck

Mechanical Anchors

Allowable Stress Design (ASD) Values for Titen HD® Rod Hanger with ¼" and ⅝" Shanks Tension Loads in Normal-Weight Concrete



* See page 13 for an explanation of the load table icons

Catalog Number	Rod Hanger Dia. (in.)	Drill Bit Dia. (in.)	Emb. Depth (in.)	Critical Edge Distance (in.)	Critical Spacing Distance (in.)	Tension Load			
						$f'_{c} \geq 2000 \text{ psi}$ Concrete		$f'_{c} \geq 4000 \text{ psi}$ Concrete	
						Ultimate (lbs.)	Allowable (lbs.)	Ultimate (lbs.)	Allowable (lbs.)
THD25112RH	¼	¼	1½	3	6	1,319	330	2,102	525
THD37218RH	⅜	¼	2½	3	6	2,210	555	3,227	805
THD37212RH	⅜	⅜	2½	3	6	3,650	915	5,275	1,320
THD50234RH	½	⅝	2¾	3	6	4,297	1,075	6,204	1,550

- The allowable loads listed are based on a safety factor of 4.0.
- Allowable loads may not be increased for short-term loading due to wind or seismic forces.
- Refer to allowable load-adjustment factors for spacing and edge distance on pages 120–121.
- The minimum concrete thickness is 1½ times the embedment depth.
- Allowable load may be interpolated for concrete compressive strengths between 2000 psi and 4000 psi.

Titen HD® Rod Coupler *Threaded Rod Anchors for Concrete Foundations*

The Titen HD® Rod Coupler is designed to be used in conjunction with a single or multi-story rod tie-down system. This anchor provides a fast and simple way to attach threaded rod to a concrete stem wall or thickened slab footing. Unlike adhesive anchors, the installation requires no special tool, cure time or secondary setting process; just drill a hole and drive the anchor.

FEATURES:

- The serrated cutting teeth and patented thread design enable the Titen HD Rod Coupler to be installed quickly and easily. Less installation time translates to lower installed cost
- The specialized heat treating process creates tip hardness to facilitate cutting while the body remain ductile
- No special setting tools are required. The Titen HD Rod Coupler installs with regular or hammer drill, ANSI size bits and standard sockets
- Compatible with threaded rods in 3/8" and 1/2" diameters

MATERIAL: Carbon steel, heat treated

FINISH: Zinc plated

INSTALLATION:



Caution: Oversized holes in the base material will reduce or eliminate the mechanical interlock of the threads with base material and will reduce the anchor's load capacity. Use a Titen HD® Rod Coupler one time only. Installing the anchor multiple times may result in excessive thread wear and reduce load capacity

- Drill a hole using the specified diameter carbide bit into the base material to a depth of at least 1/2" deeper than the required embedment.
- Blow the hole clean of dust and debris using compressed air. Overhead application need not be blown clean.
- Tighten the anchor with appropriate size socket until the head sits flush against base material



Titen HD® Rod Coupler
U.S. Patent
5,674,035 & 6,623,228

Titen HD® Rod Coupler Product Data

Size ¹ (in)	Model No.	Accepts Rod Dia. (in.)	Drill Bit Dia. (in)	Wrench Size (in)	Quantity	
					Box	Carton
3/8 x 6 3/4	THD37634RC	3/8	3/8	3/16	50	100
1/2 x 9 3/4	THD50934RC	1/2	1/2	3/4	20	40

1. Length is measured from the underside of the coupler.

Installation Sequence

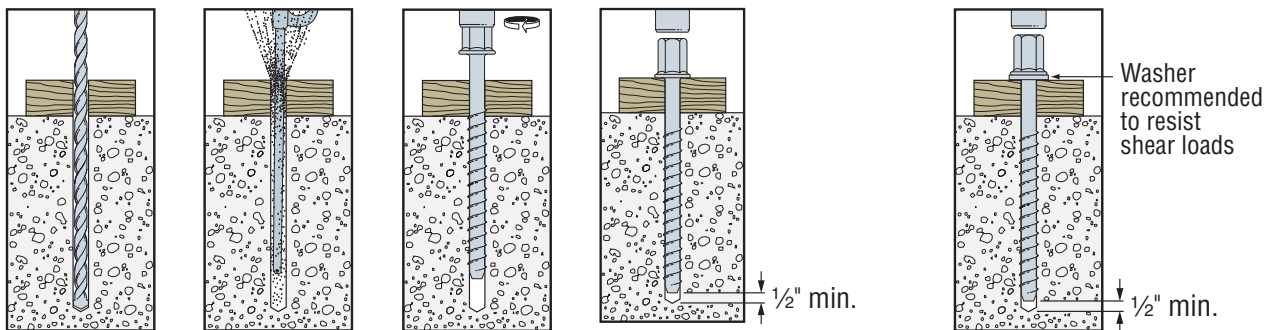

Titen HD® Rod Coupler Threaded Rod Anchors for Concrete Foundations



*See page 13 for an explanation of the load table icons

Titen HD® Rod Coupler Tension Loads in Normal-Weight Concrete Stemwall

Size in. (mm)	Drill Bit Dia. in.	Embed. Depth in. (mm)	Stemwall Width in. (mm)	Minimum Edge Dist. in. (mm)	Minimum End Dist. in. (mm)	Minimum Spacing Dist. in. (mm)	Tension Load Based on Concrete Strength		Tension Load Based on Connected Rod Strength
							$f'_c \geq 2500$ psi (17.2 Mpa) Concrete		A307 (SAE 1018)
							Ultimate lbs. (kN)	Allowable lbs. (kN)	Allowable lbs. (kN)
3/8 (9.5)	3/8	5 (127)	8 (203)	1 1/4 (44)	10 (254)	20 (508)	8,900 (39.6)	2,225 (9.9)	2,105 (9.4)
1/2 (12.7)	1/2	8 (203)	8 (203)	1 1/4 (44)	16 (406)	32 (813)	15,540 (69.1)	3,885 (17.3)	3,750 (16.7)

1. Allowable load must be the lesser of the concrete or steel strength.
2. The allowable loads based on concrete strength are based on a factor of safety of 4.0.
3. The allowable load based on steel strength is limited by the strength of the coupler nut supplied with this anchor. Use of higher strength rod will not increase allowable loads.
4. The minimum concrete thickness is 1.5 times the embedment depth.
5. Tension and shear loads may be combined using the straight-line interaction equation (n=1).

Titen HD® Rod Coupler Shear Loads in Normal-Weight Concrete Stemwall, Load Applied Parallel to Concrete Edge



*See page 13 for an explanation of the load table icons

Size in. (mm)	Drill Bit Dia. in.	Embed. Depth in. (mm)	Stemwall Width in. (mm)	Minimum Edge Dist. in. (mm)	Minimum End Dist. in. (mm)	Minimum Spacing Dist. in. (mm)	Shear Load Based on Conc. Edge Dist.	
							$f'_c \geq 2500$ psi (17.2 Mpa) Concrete	
							Ultimate lbs. (kN)	Allowable lbs. (kN)
1/2 (12.7)	1/2	8 (203)	8 (203)	1 1/4 (44)	16 (406)	32 (813)	6,200 (27.6)	1,550 (6.9)

1. Install with a washer (not supplied with anchor) when used to resist shear loads.
2. The allowable load based on concrete edge distance is based on a factor of safety of 4.0. Steel strength does not control.
3. The minimum concrete thickness is 1.5 times the embedment depth.
4. Tension and shear loads may be combined using the straight-line interaction equation (n=1).



Torq-Cut™ Self-Undercutting Anchor for Cracked and Uncracked Concrete

The Torq-Cut™ self-undercutting anchor is a heavy-duty, high-capacity anchor designed and tested for use in cracked and uncracked concrete under static and seismic loading conditions. It is designed to meet the stringent requirements of the 2006 and 2009 IBC for post-installed anchors. The built-in ring with hardened cutters expands with installation torque forming undercut grooves in the concrete. This interlocking connection between the anchor and the concrete provides superior load carrying capacity.

FEATURES:

- Self-undercutting feature provides higher load carrying capacity than conventional mechanical anchors
- AC193 code tested to ensure outstanding performance in both cracked and uncracked concrete
- Excellent for resisting seismic and vibratory loads
- Suitable for Seismic Design Categories A-F
- Ductile steel rod provides consistent, reliable performance
- Specially designed, low-friction expansion cone minimizes binding and speeds installation
- Installs just like a conventional expansion anchor, no special tool, drill bit, or secondary drilling is required
- The head is stamped with the Simpson Strong-Tie® "S" sign and size identification for easy post installation verification

MATERIAL: ASTM A193 grade B7 or B7M rod with SAE J403 grade 1144 undercut expansion ring and expansion cone

FINISH: Zinc plated **CODES:** ICC-ES pending

⚠ The load tables list values based upon results from the most recent testing and may not reflect those in current code reports. Where additional local jurisdiction requirements apply, consult the current reports for applicable load values.

TEST CRITERIA: The Torq-Cut anchor has been tested in accordance with ICC-ES's Acceptance Criteria for Mechanical Anchors in Concrete Elements (AC193) and ACI 355.2 for the following:

- Static tension and shear loading in cracked and uncracked concrete
- Seismic and wind loading in cracked and uncracked concrete
- Performance in cracked concrete

Torq-Cut Setting Tool

The TCAST is the steel setting tool used to install the Torq-Cut anchor. It is used to drive the anchor into the pre-drilled hole and protect the threads on the Torq-Cut from being damaged by hammer blows.

INSTALLATION:

⚠ Caution: Oversized holes in the base material will make it difficult to set the anchor and will reduce the anchor's load capacity. Do not use an impact wrench to set or tighten the Torq-Cut anchor.

Installation Instructions: Pre-Set Version

1. Drill a hole in the base material to the specified embedment depth using the appropriate diameter carbide drill bit specified for each diameter.
2. Blow the hole clean using compressed air.
3. Assemble the anchor with nut and washer and finger tighten nut so all components are snug (spacer sleeve, expansion sleeve and cone). The bottom of the threaded rod should be flush with the bottom of the cone.
4. Place the anchor into the drilled hole and use a hammer and setting tool to drive the anchor until the washer and nut are tight against the surface of the base material.
5. Remove the nut and washer and install the fixture. Re-assemble the nut and washer over the fixture.
6. Tighten to the required installation torque.

Installation Instructions: Through-Set Version

1. Drill a hole in the base material to the specified embedment depth using the appropriate diameter carbide drill bit specified for each diameter.
2. Blow the hole clean using compressed air.
3. Assemble the anchor with nut and washer and finger tighten nut so all components are snug (spacer sleeve, expansion sleeve and cone). The bottom of the threaded rod should be flush with the bottom of the cone.
4. Place the anchor through the fixture and into the drilled hole. Use a hammer and setting tool to drive the anchor until the washer and nut are tight against the fixture.
5. Tighten to the required installation torque.

APPLICATION: Interior environment where low levels of moisture and corrosive chemicals are present

SUGGESTED SPECIFICATIONS:

Self-undercutting anchors shall have an expansion ring with undercutting teeth which expands by tightening the nut that pushes the ring into a cone expander via a spacer sleeve. The anchor shall have been tested and qualified for performance in cracked and uncracked concrete per ACI 355.2 and ICC-ES AC193. Undercut anchor shall be the Torq-Cut self-undercutting anchor from Simpson Strong-Tie, Pleasanton, CA, and be installed following the Simpson Strong-Tie instructions.



**Torq-Cut™
Self-Undercutting Anchor**
U.S. Patent 7,357,613



**Torq-Cut™
Setting Tool**
(Sold separately)

Installation Sequence

Steps 1, 2, 3 – Pre-Set and Through-Set Version

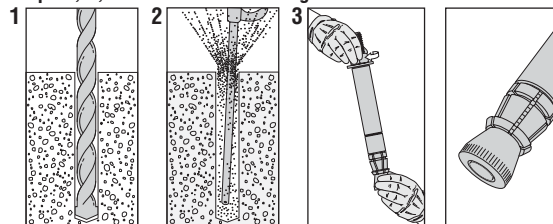

Steps 4, 5, 6 – Pre-Set Version

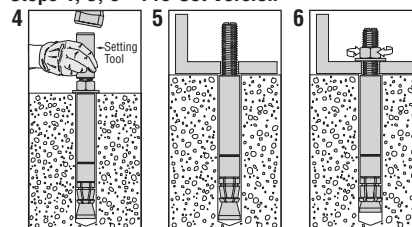

Steps 4, 5 – Through-Set Version

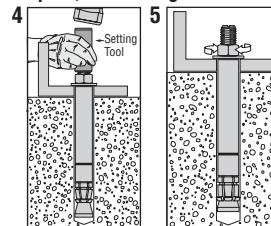

Mechanical Anchors

Torq-Cut Anchor Installation Data

Nominal Anchor Dia (in)	3/8	1/2	5/8	3/4
Drill Bit Size (in)	5/8	7/8	1	1 1/4
Fixture Hole Dia Range Pre-Set (in)	7/16-1/2	9/16-3/4	1 1/16-7/8	1 3/16-1 1/8
Min. Fixture Hole Dia Through-Set (in)	1 1/16	1 5/16	1 1/8	1 5/16
Wrench Size (in)	9/16	3/4	15/16	1 1/8
Setting Tool Required	TCAST37	TCAST50	TCAST62	TCAST75

Torq-Cut™ Self-Undercutting Anchor for Cracked and Un-cracked Concrete

Torq-Cut™ Anchor Product Data, Pre-Set Version¹

Size (in.)	Model No.	Drill Bit Dia. (in.)	Min. Drilled Hole Depth (A) (in.)	Min. Effective Embedment Depth, h_{ef} (C) (in.)	Max. Fixture Thickness (F) (in.)	Min. Fixture Hole Dia. (in.)	Threaded Rod Length (D) (in.)	Quantity	
								Box	Carton
3/8 x 6	TCAP370600	5/8	5 1/2	4	3/4	7/16	6	10	40
1/2 x 8 3/4	TCAP500834	7/8	7 1/2	5 3/4	1 1/4	9/16	8 3/4	5	10
1/2 x 9 1/2	TCAP500912	7/8	7 1/2	5 3/4	2	9/16	9 1/2	5	10
5/8 x 11 1/2	TCAP621112	1	10	8	1 1/2	1 1/16	11 1/2	4	8
5/8 x 12 1/2	TCAP621212	1	10	8	2 1/2	1 1/16	12 1/2	4	8
3/4 x 14 5/8	TCAP751458	1 1/4	12 1/2	10 1/4	2	1 5/16	14 5/8	4	8
3/4 x 16 5/8	TCAP751658	1 1/4	12 1/2	10 1/4	4	1 5/16	16 5/8	4	8

1. See detail below

Torq-Cut Anchor Product Data, Through-Set Version¹

Size (in.)	Model No.	Drill Bit Dia. (in.)	Min. Drilled Hole Depth (A) (in.)	Min. Effective Embedment Depth, h_{ef} (C) (in.)	Max. Fixture Thickness (F) (in.)	Min. Fixture Hole Dia. (in.)	Threaded Rod Length (D) (in.)	Quantity	
								Box	Carton
3/8 x 6	TCAT370600	5/8	5 1/2	4	3/4	1 1/16	6	10	40
1/2 x 8 3/4	TCAT500834	7/8	7 1/2	5 3/4	1 1/4	1 5/16	8 3/4	5	10
1/2 x 9 1/2	TCAT500912	7/8	7 1/2	5 3/4	2	1 5/16	9 1/2	5	10
5/8 x 11 1/2	TCAT621112	1	10	8	1 1/2	1 1/16	11 1/2	4	8
5/8 x 12 1/2	TCAT621212	1	10	8	2 1/2	1 1/16	12 1/2	4	8
3/4 x 14 5/8	TCAT751458	1 1/4	12 1/2	10 1/4	2	1 5/16	14 5/8	4	8
3/4 x 16 5/8	TCAT751658	1 1/4	12 1/2	10 1/4	4	1 5/16	16 5/8	4	8

1. See detail below

Torq-Cut Anchor Material Specifications

Carbon Steel Component Materials					
Threaded Rod	Nut	Washer	Spacer Sleeve	Undercut Expansion Ring	Expansion Cone
ASTM A193 ¹	SAE J995, Grade 8	ASTM F436, Type 1	SAE J403 Grade 1045 Steel	SAE J403 Grade 1045 Steel	SAE J403 Grade 1144 Steel
Zinc Plated ASTM B633 SC1	Commercial Zinc	Commercial Zinc	Zinc Plated ASTM B633 SC1	Zinc Plated ASTM B633 SC1	Zinc Plated ASTM B633 SC1

1. 3/8" TCA uses ASTM A193 Grade B7 rod. 1/2", 5/8" and 3/4" TCA uses ASTM A193 Grade B7M rod.

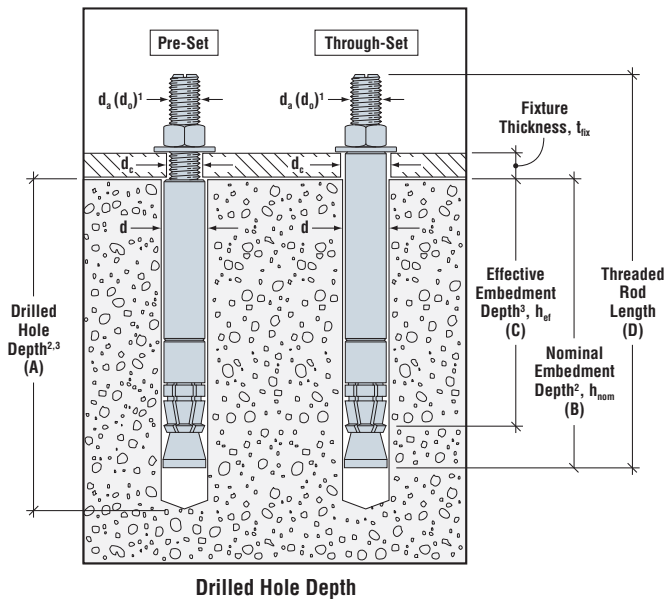

1. The notation in parentheses is for the 2006 IBC.
2. The Drilled Hole Depth is 1/2" greater than the Nominal Embedment Depth.
3. For the Through-Set version of the Torq-Cut anchor, if the actual Fixture Thickness (t_{fx}) is less than the Maximum Fixture Thickness (F), the Minimum Drilled Hole Depth (A) must be increased as follows:

$$\text{Drilled Hole Depth} = A + (F - t_{fx})$$
 Similarly, the Minimum Effective Embedment Depth (C) is increased as follows:

$$\text{Effective Embedment Depth} = C + (F - t_{fx})$$

Torq-Cut™ Self-Undercutting Anchor for Cracked and Uncracked Concrete

Torq-Cut™ Anchor Installation and Additional Data¹

Characteristic	Symbol	Units	Nominal Anchor Diameter (inch)			
			3/8	1/2	5/8	3/4
Installation Information						
Drill Bit Diameter	d	in.	5/8	7/8	1	1 1/4
Pre-Set Fixture Hole Diameter Range ²	d_c	in.	7/16-1/2	9/16-3/4	11/16-7/8	13/16-1 1/8
Through-Set Minimum Fixture Hole Diameter ²	d_c	in.	11/16	15/16	1 1/16	1 5/16
Installation Torque	T_{inst}	ft-lb	55	90	185	240
Minimum Nominal Embedment Depth	h_{nom}	in.	5	7	9 1/2	12
Minimum Overall Depth of Drilled Hole	h_{hole}	in.	5 1/2	7 1/2	10	12 1/2
Critical Edge Distance	c_{ac}	in.	6	8 5/8	12	15 3/8
Minimum Edge Distance	c_{min}	in.	6	7	10	7 3/4
Minimum Spacing	s_{min}	in.	6	7	9	7 3/4
Minimum Concrete Thickness	h_{min}	in.	6	8 5/8	12	15 5/8
Additional Data						
Anchor Category	category	—	1	1	1	1
Yield Strength	f_{ya}	ksi	105	80	80	80
Tensile Strength	f_{uta}	ksi	125	100	100	100
Effective Tensile and Shear Stress Area	A_{se}	in ²	0.078	0.142	0.226	0.334
Axial Stiffness in Service Load Range – uncracked concrete	β_{uncr}	lb/in.	635,830			
Axial Stiffness in Service Load Range – cracked concrete	β_{cr}	lb/in.	346,694			

1. The information presented in this table is to be used in conjunction with the design criteria of ACI 318 Appendix D.

2. The clearance must comply with applicable code requirements for the connected element.



*See page 13 for an explanation of the load table icons

Torq-Cut™ Anchor Tension Strength Design Data¹

Characteristic	Symbol	Units	Nominal Anchor Diameter (inch)			
			3/8	1/2	5/8	3/4
Minimum Nominal Embedment Depth	h_{nom}	in.	5	7	9 1/2	12
Steel Strength in Tension						
Nominal Steel Strength in Tension	N_{sa}	lb.	9,690	14,190	22,600	33,450
Strength Reduction Factor – Steel Failure	ϕ_{sa}	—	0.75 ²			
Concrete Breakout Strength in Tension⁶						
Minimum Effective Embedment Depth	h_{ef}	in.	4	5 3/4	8	10 1/4
Critical Edge Distance	c_{ac}	in.	6	8 5/8	12	15 3/8
Effectiveness Factor – Uncracked Concrete	k_{uncr}	—	24	24	24	24
Effectiveness Factor – Cracked Concrete	k_{cr}	—	17	21	17	21
Modification Factor	$\psi_{c,N}$	—	1.0	1.0	1.0	1.0
Strength Reduction Factor – Concrete Breakout Failure	ϕ_{cb}	—	0.65 ⁵			
Pullout Strength in Tension⁶						
Pullout Strength Uncracked Concrete	$N_{p,uncr}$	lb	7,400 ⁷	N/A ³	N/A ³	N/A ³
Pullout Strength Cracked Concrete	$N_{p,cr}$	lb	6,950 ⁷	N/A ³	N/A ³	N/A ³
Strength Reduction Factor - Pullout Failure	ϕ_p	—	0.65 ^{4,7}	N/A ³	N/A ³	N/A ³
Tension Resistance for Seismic Applications⁶						
Tension Resistance - Seismic Loads	N_{eq}	lb	9,690	14,190	22,600	33,450
Strength Reduction Factor – Steel Failure	ϕ_{sa}	—	0.75 ²			

- The information presented in this table must be used in conjunction with the design criteria of ACI 318 Appendix D, except as modified below.
- The tabulated value of ϕ_{sa} applies when the load combinations of Section 1605.2.1 of the IBC, or ACI 318 Section 9.2 are used. If the load combinations of ACI 318 Appendix C are used, the appropriate value of ϕ_{sa} must be determined in accordance with ACI 318 D.4.5. Torq-Cut™ anchors are ductile steel elements as defined in ACI 318 D.1.
- N/A (Not Applicable) denotes that pullout resistance does not need to be considered.
- The tabulated value of ϕ_p applies when the load combinations of Section 1605.2.1 of the IBC, or ACI 318 Section 9.2 are used and the requirements of ACI 318 D.4.4(c) for Condition B are met. If the load combinations of ACI 318 Appendix C are used, appropriate value of ϕ must be determined in accordance with ACI 318 Section D.4.5(c).

- The tabulated value of ϕ_{cb} applies when both the load combinations of Section 1605.2.1 of the IBC, or ACI 318 Section 9.2 are used and the requirements of ACI 318 Section D.4.4(c) for Condition B are met. Condition B applies where supplementary reinforcement is not provided. For installations where complying supplementary reinforcement can be verified, the ϕ_{cb} factors described in ACI 318 D.4.4 for Condition A are allowed. If the load combinations of ACI 318 Section 9.2 are used and the requirements of ACI 318 Section D.4.4 for Condition A are met, the appropriate value of ϕ_{cb} must be determined in accordance with ACI 318 D.4.4(c). If the load combinations of ACI 318 Appendix C are used, the appropriate value of ϕ_{cb} must be determined in accordance with ACI 318 D.4.5(c).
- For sand-lightweight concrete, in lieu of ACI 318 Section D.3.4, modify the value of concrete breakout strength, $N_{p,cr}$, $N_{p,uncr}$ and N_{eq} by 0.6. All-lightweight concrete is beyond the scope of this table.
- Pullout strength applies for 2500 psi $\leq f'_c \leq$ 3500 psi concrete. For $f'_c >$ 3500 psi concrete, pullout strength need not be considered since steel controls for concrete strengths greater than 3500 psi.

Torq-Cut™ Self-Undercutting Anchor for Cracked and Uncracked Concrete

Torq-Cut™ Shear Strength Design Data^{1,5}



*See page 13 for an explanation of the load table icons

Characteristic	Symbol	Units	Nominal Anchor Diameter (inch)			
			3/8	1/2	5/8	3/4
Minimum Nominal Embedment Depth	h_{nom}	in.	5	7	9½	12
Steel Strength in Shear						
Steel Strength in Shear	V_{sa}	lb.	5,815	8,515	13,560	20,070
Strength Reduction Factor – Steel Failure	ϕ_{sa}	—	0.65 ²			
Concrete Breakout Strength in Shear⁵						
Outside Diameter	d_a ⁶	in.	5/8	7/8	1	1¼
Load Bearing Length of Anchor in Shear	ℓ_e	in.	2.8	4.3	5.8	7.5
Strength Reduction Factor – Concrete Breakout Failure	ϕ_{cb}	—	0.70 ³			
Concrete Pryout Strength in Shear						
Coefficient for Pryout Strength	k_{cp}	—	2.0	2.0	2.0	2.0
Strength Reduction Factor – Concrete Pryout Failure	ϕ_{cp}	—	0.70 ⁴			
Steel Strength in Shear for Seismic Applications						
Steel Strength in Shear for Seismic Loads	V_{eq}	lb	5,815	8,515	13,560	20,070
Strength Reduction Factor – Steel Failure	ϕ_{sa}	—	0.65 ²			

- The information presented in this table must be used in conjunction with the design criteria of ACI 318 Appendix D, except as modified below.
- The tabulated value of ϕ_{sa} applies when the load combinations of Section 1605.2.1 of the IBC, or ACI 318 Section 9.2 are used and the requirements of ACI 318 D.4.4(c) for Condition B are met. If the load combinations of ACI 318 Appendix C are used, the appropriate value of ϕ_{sa} must be determined in accordance with ACI 318 D.4.5. Torq-Cut™ anchors are ductile steel elements as defined in ACI 318 D.1.
- The tabulated value of ϕ_{cb} applies when both the load combinations of Section 1605.2.1 of the IBC, or ACI 318 Section 9.2 are used and the requirements of ACI 318 Section D.4.4(c) for Condition B are met. Condition B applies where supplementary reinforcement is not provided. For installations where complying supplementary reinforcement can be verified, the ϕ_{cb} factors described in ACI 318 Section D.4.4 for Condition A are allowed. If the load combinations of ACI 318 Section 9.2 are used and the requirements of ACI 318 Section D.4.4 for Condition A are met, the appropriate value of ϕ_{cb} must be determined in accordance with ACI 318 Section D.4.4(c). If the load combinations of ACI 318 Appendix C are used, the appropriate value of ϕ_{cb} must be determined in accordance with ACI 318 Section D.4.5(c).
- The tabulated value of ϕ_{cp} applies when both the load combinations of IBC Section 1605.2.1 or ACI 318 Section 9.2 are used and the requirements of ACI 318 D.4.4(c) for Condition B are met. If the load combinations of ACI 318 Appendix C are used, the appropriate value of ϕ_{cp} must be determined in accordance with ACI 318 D.4.5(c).
- For sand-lightweight concrete, in lieu of ACI 318 Section D.3.4, modify the value of concrete breakout strength by 0.60. All-lightweight concrete is beyond the scope of this table.
- For the 2006 IBC, d_o replaces d_a .

Wedge-All® Wedge Anchors

The Wedge-All® wedge anchors are a non-bottom bearing, wedge-style expansion anchor for use in solid concrete or grout-filled concrete masonry. A one-piece clip ensures uniform holding capacity that increases as tension is applied. The threaded stud version is available in eight diameters and multiple lengths. A single size tie-wire version is available for wire supported fixtures. Threaded studs are set by tightening the nut. Tie-wire anchors are set with the claw end of a hammer.

WEDGE-ALL SPECIAL FEATURES:

- One piece wrap around clip
- Threaded end is chamfered for ease of starting nut
- Most sizes feature full thread for added versatility

MATERIAL: Carbon and stainless steel

FINISH: Carbon steel anchors are available zinc plated or mechanically galvanized.

CODES: ICC-ES ESR-1396 (CMU); City of L.A. RR24682; Factory Mutual 3017082, 3031136, and 3043442; Florida FL 11506.8; Underwriters Laboratories File Ex3605; Meets requirements of Federal Specifications A-A-1923A, Type 4. The Tie-Wire anchor is not code listed.

⚠ The load tables list values based upon results from the most recent testing and may not reflect those in current code reports. Where code jurisdictions apply, consult the current reports for applicable load values.

TEST CRITERIA: The Wedge-All anchor has been tested in accordance with ICC-ES's Acceptance Criteria for Expansion Anchors (AC01) for the following:

- Static tension and shear loading
- Seismic and wind loading
- Combination tension and shear loading
- Critical and minimum edge distance

INSTALLATION:

- Holes in metal fixtures to be mounted should exceed nominal anchor diameter by 1/16" for 1/4" thru 5/8" diameter anchors, and by 1/8" for all other diameters.
- Do not use an impact wrench to set or tighten the Wedge-All.

⚠ Caution: Oversized holes in the base material will make it difficult to set the anchor and will reduce the anchor's load capacity.

Threaded studs:

- Drill a hole in the base material using a carbide drill bit the same diameter as the nominal diameter of the anchor to be installed. Drill the hole to the specified embedment depth and blow it clean using compressed air. Overhead installations need not be blown clean. Alternatively, drill the hole deep enough to accommodate embedment depth and dust from drilling.
- Assemble the anchor with nut and washer so the top of the nut is flush with the top of the anchor. Place the anchor in the fixture and drive into the hole until washer and nut are tight against fixture.
- Tighten to the required installation torque.

Tie-Wire:

- Drill a hole at least 1 1/2" deep using a 1/4" diameter carbide tipped bit.
- Drive the anchor into the hole until the head is seated against the base material.
- Set the anchor by prying/pulling the head with the claw end of the hammer.

SUGGESTED SPECIFICATIONS:

Wedge anchors shall be a threaded stud with an integral cone expander and a single piece expansion clip. The stud shall be carbon steel with a minimum 70,000 psi tensile strength, or type 303, 304 or 316 stainless steel, as called for on the drawings. Anchors shall meet Federal Specification A-A-1923A, Type 4. Anchors shall be Wedge-All® anchors from Simpson Strong-Tie, Pleasanton, CA. Anchors shall be installed following the Simpson Strong-Tie instructions for Wedge-All anchors.



Wedge-All® Anchor

Tie-Wire Anchor (Zinc plate only)

Wedge-All® Anchor Installation Sequence

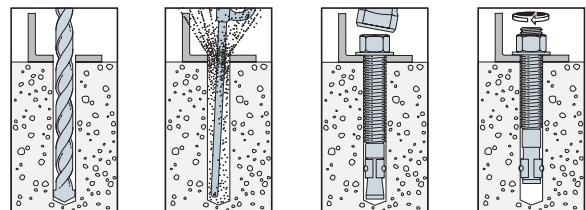

Tie-Wire Anchor Installation Sequence

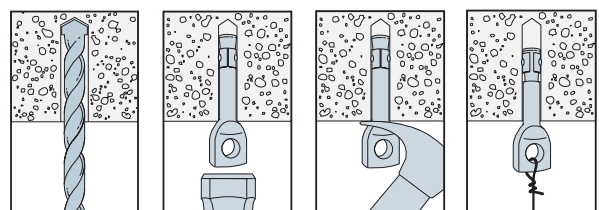

Wedge-All® Anchor Installation Data

Wedge-All Dia. (in.)	1/4	3/8	1/2	5/8	3/4	7/8	1	1 1/4
Bit Size (in.)	1/4	3/8	1/2	5/8	3/4	7/8	1	1 1/4
Min. Fixture Hole (in.)	5/16	7/16	9/16	1 1/16	7/8	1	1 1/8	1 3/8
Wrench Size (in.)	7/16	9/16	3/4	15/16	1 1/8	1 1/16	1 1/2	1 7/8

Length Identification Head Marks on Wedge-All® Anchors (corresponds to length of anchor – inches).

Mark	A	B	C	D	E	F	G	H	I	J	K	L	M	N	O	P	Q	R	S	T	U	V	W	X	Y	Z
From	1 1/2	2	2 1/2	3	3 1/2	4	4 1/2	5	5 1/2	6	6 1/2	7	7 1/2	8	8 1/2	9	9 1/2	10	11	12	13	14	15	16	17	18
Up To But Not Including	2	2 1/2	3	3 1/2	4	4 1/2	5	5 1/2	6	6 1/2	7	7 1/2	8	8 1/2	9	9 1/2	10	11	12	13	14	15	16	17	18	19

Wedge-All® Carbon-Steel Wedge Anchors

Wedge-All® Anchor Product Data
Carbon Steel: Zinc Plated and Mechanically Galvanized

Size (in.)	Carbon Steel Model No.	Mechanically Galvanized Model No.	Drill Bit Dia. (in.)	Thread Length (in.)	Quantity		
					Box	Carton	
1/4 x 1 1/2	TWD25112 ⁴	•	1/4	Hole dia. is 9/32	100	500	
1/4 x 1 3/4	WA25134	WA25134MG		15/16	100	500	
1/4 x 2 1/4	WA25214	WA25214MG		1 1/16	100	500	
1/4 x 3 1/4	WA25314	WA25314MG		2 7/16	100	500	
3/8 x 2 1/4	WA37214	WA37214MG	3/8	1 1/8	50	250	
3/8 x 2 3/4	WA37234	WA37234MG		1 3/8	50	250	
3/8 x 3	WA37300	WA37300MG		1 7/8	50	250	
3/8 x 3 1/2	WA37312	WA37312MG		2 1/2	50	250	
3/8 x 3 3/4	WA37334	WA37334MG		2 5/8	50	250	
3/8 x 5	WA37500	WA37500MG		3 7/8	50	200	
3/8 x 7	WA37700	WA37700MG		5 7/8	50	200	
1/2 x 2 3/4	WA50234	WA50234MG		1/2	1 9/16	25	125
1/2 x 3 3/4	WA50334	WA50334MG	2 9/16		25	125	
1/2 x 4 1/4	WA50414	WA50414MG	2 19/16		25	100	
1/2 x 5 1/2	WA50512	WA50512MG	4 1/16		25	100	
1/2 x 7	WA50700	WA50700MG	4 9/16		25	100	
1/2 x 8 1/2	WA50812	WA50812MG	6		25	50	
1/2 x 10	WA50100	WA50100MG	6		25	50	
1/2 x 12	WA50120	WA50120MG	6		25	50	
5/8 x 3 1/2	WA62312	WA62312MG	5/8		1 7/8	20	80
5/8 x 4 1/2	WA62412	WA62412MG			2 7/8	20	80
5/8 x 5	WA62500	WA62500MG		3 3/8	20	80	
5/8 x 6	WA62600	WA62600MG		4 3/8	20	80	
5/8 x 7	WA62700	WA62700MG		5 3/8	20	80	
5/8 x 8 1/2	WA62812	WA62812MG		6	20	40	
5/8 x 10	WA62100	WA62100MG		6	10	20	
5/8 x 12	WA62120	WA62120MG		6	10	20	
3/4 x 4 1/4	WA75414	WA75414MG	3/4	2 3/8	10	40	
3/4 x 4 3/4	WA75434	WA75434MG		2 7/8	10	40	
3/4 x 5 1/2	WA75512	WA75512MG		3 5/8	10	40	
3/4 x 6 1/4	WA75614	WA75614MG		4 3/8	10	40	
3/4 x 7	WA75700	WA75700MG		5 1/8	10	40	
3/4 x 8 1/2	WA75812	WA75812MG		6	10	20	
3/4 x 10	WA75100	WA75100MG		6	10	20	
3/4 x 12	WA75120	WA75120MG		6	5	10	
7/8 x 6	WA87600	WA87600MG	7/8	2 1/8	5	20	
7/8 x 8	WA87800	WA87800MG		2 1/8	5	10	
7/8 x 10	WA87100	WA87100MG		2 1/8	5	10	
7/8 x 12	WA87120	WA87120MG		2 1/8	5	10	
1 x 6	WA16000	WA16000MG	1	2 1/4	5	20	
1 x 9	WA19000	WA19000MG		2 1/4	5	10	
1 x 12	WA11200	WA11200MG		2 1/4	5	10	
1 1/4 x 9	WA12590	WA12590MG	1 1/4	2 3/4	5	10	
1 1/4 x 12	WA12512	WA12512MG		2 3/4	5	10	

1. The published length is the overall length of the anchor. Allow one anchor diameter for the nut and washer thickness plus the fixture thickness when selecting the minimum length.
2. Special lengths are available on request. Load values are valid as long as minimum embedment depths are satisfied.
3. Tie-Wire Wedge-All® anchor, overall length is 2".
4. Tie-Wire Wedge-All® anchor also available in bulk quantity of 2,000, model TWD25112B.
5. Bulk packaged Wedge-All® anchors available, call Simpson Strong-Tie® for details.

Material Specifications

Carbon Steel - Zinc Plated			
Component Materials			
Anchor Body	Nut	Washer	Clip
Material Meets minimum 70,000 psi tensile strength	Carbon Steel ASTM A 563, Grade A	Carbon Steel	Carbon Steel



Application: Interior environment, low level of corrosion resistance. See page 11 for more corrosion information.



Material Specifications

Carbon Steel - Mechanically Galvanized ¹			
Component Materials			
Anchor Body	Nut	Washer	Clip
Material Meets minimum 70,000 psi tensile strength	Carbon Steel ASTM A 563, Grade A	Carbon Steel	Carbon Steel

1. Mechanical Galvanizing meets ASTM B695, Class 55, Type 1.



Application: Exterior unpolluted environment, medium level of corrosion resistance. Well suited to humid environments. See page 11 for more corrosion information.

Wedge-All® Stainless-Steel Wedge Anchors

Wedge-All® Anchor Product Data - Stainless Steel

Size (in.)	Type 304/303 Stainless Model No. ¹	Type 316 Stainless Model No. ²	Drill Bit Dia. (in.)	Thread Length (in.)	Standard Quantity		Mini-Pack Quantity "R" Suffix in Model No. (see note below)	
					Box	Carton	Box	Carton
1/4 x 1 3/4	WA251344SS	WA251346SS	1/4	1 5/16	100	500	20	200
1/4 x 2 1/4	WA252144SS	WA252146SS		1 7/16	100	500	20	200
1/4 x 3 1/4	WA253144SS	WA253146SS		2 7/16	100	500	20	200
3/8 x 2 1/4	WA372144SS	WA372146SS	3/8	1 1/8	50	250	20	200
3/8 x 2 3/4	WA372344SS	WA372346SS		1 5/8	50	250	20	200
3/8 x 3	WA373004SS	WA373006SS		1 7/8	50	250	20	200
3/8 x 3 1/2	WA373124SS	WA373126SS		2 1/2	50	250	20	200
3/8 x 3 3/4	WA373344SS	WA373346SS		2 5/8	50	250	20	200
3/8 x 5	WA375004SS	WA375006SS		3 7/8	50	200	10	100
3/8 x 7	WA377004SS	WA377006SS		5 7/8	50	200	18	80
1/2 x 2 3/4	WA502344SS	WA502346SS	1/2	1 5/16	25	125	10	100
1/2 x 3 3/4	WA503344SS	WA503346SS		2 5/16	25	125	10	100
1/2 x 4 1/4	WA504144SS	WA504146SS		2 19/16	25	100	-	-
1/2 x 5 1/2	WA505124SS	WA505126SS		4 1/16	25	100	10	80
1/2 x 7	WA507004SS	WA507006SS		5 9/16	25	100	4	32
1/2 x 8 1/2	WA50812SS	WA508123SS		2	25	50	4	16
1/2 x 10	WA50100SS	WA501003SS		2	25	50	4	16
1/2 x 12	WA50120SS	WA501203SS	2	25	50	4	16	
5/8 x 3 1/2	WA623124SS	WA623126SS	5/8	1 7/8	20	80	10	100
5/8 x 4 1/2	WA624124SS	WA624126SS		2 7/8	20	80	10	80
5/8 x 5	WA625004SS	WA625006SS		3 3/8	20	80	10	80
5/8 x 6	WA626004SS	WA626006SS		4 3/8	20	80	10	80
5/8 x 7	WA627004SS	WA627006SS		5 3/8	20	80	4	16
5/8 x 8 1/2	WA62812SS	WA628123SS		2	20	40	4	16
5/8 x 10	WA62100SS	WA621003SS		2	10	20	4	16
5/8 x 12	WA62120SS	WA621203SS	2	10	20	4	16	
3/4 x 4 1/4	WA754144SS	WA754146SS	3/4	2 3/8	10	40	4	40
3/4 x 4 3/4	WA754344SS	WA754346SS		2 7/8	10	40	4	40
3/4 x 5 1/2	WA755124SS	WA755126SS		3 3/8	10	40	4	32
3/4 x 6 1/4	WA756144SS	WA756146SS		4 3/8	10	40	4	32
3/4 x 7	WA757004SS	WA757006SS		5 1/8	10	40	4	32
3/4 x 8 1/2	WA75812SS	WA758123SS		2 1/4	10	20	4	16
3/4 x 10	WA75100SS	WA751003SS		2 1/4	10	20	4	16
3/4 x 12	WA75120SS	WA751203SS	2 1/4	5	10	4	16	
7/8 x 6	WA87600SS	WA876003SS	7/8	2 1/8	5	20	4	8
7/8 x 8	WA87800SS	WA878003SS		2 1/8	5	10	4	8
7/8 x 10	WA87100SS	WA871003SS		2 1/8	5	10	4	8
7/8 x 12	WA87120SS	WA871203SS		2 1/8	5	10	-	-
1 x 6	WA16000SS	WA160003SS	1	2 1/4	5	20	4	8
1 x 9	WA19000SS	WA190003SS		2 1/4	5	10	4	8
1 x 12	WA11200SS	WA112003SS		2 1/4	5	10	4	8
1 1/4 x 9	WA12590SS	WA125903SS	1 1/4	2 3/4	5	10	4 ³	8
1 1/4 x 12	WA12512SS	WA125123SS		2 3/4	5	10	4 ³	8

1. Anchors with the "SS" suffix in the model number are manufactured from type 303 stainless steel, the remaining anchors (with the "4SS" suffix) are manufactured from type 304 stainless steel. Type 303 stainless anchors may require extra lead time, call factory for details. Types 303 and 304 stainless steel perform equally well in certain corrosive environments.
2. Anchors with the "3SS" suffix in the model number may require extra lead time. Call Simpson Strong-Tie for details.
3. These package quantities available in type 303 stainless steel only.
4. The published length is the overall length of the anchor. Allow one anchor diameter for the nut and washer thickness plus the fixture thickness when selecting a length.

5. Special lengths are available on request. Load values are valid as long as minimum embedment depths are satisfied.

Mini Pack: These package quantities must be ordered with a "R" suffix on the end of the standard model number. (example: WA505124SS-R).

Material Specifications

Type 304/303 Stainless Steel ¹			
Component Materials			
Anchor Body	Nut	Washer	Clip
Type 303 and 304 Stainless Steel	Type 18-8 Stainless Steel	Type 18-8 Stainless Steel	Type 304 or 316 Stainless Steel

1. Type 303 and 304 stainless steels perform equally well in certain corrosive environments. Larger sizes are manufactured from type 303.

Application: Exterior environment, high level of corrosion resistance. Resistant to organic chemicals, many inorganic chemicals, mild atmospheric pollution and mild marine environments (not in direct contact with salt water). See page 11 for more corrosion information.

Material Specifications

Type 316 Stainless Steel ¹			
Component Materials			
Anchor Body	Nut	Washer	Clip
Type 316 Stainless Steel	Type 316 Stainless Steel	Type 316 Stainless Steel	Type 316 Stainless Steel

1. Type 316 stainless steel provides the greatest degree of corrosion resistance offered by Simpson Strong-Tie®.

Application: Exterior environment, high level of corrosion resistance. Resistant to chlorides, sulfuric acid compounds and direct contact with salt water. See page 11 for more corrosion information.



Wedge-All® Wedge Anchors

Tension Loads for Carbon-Steel Wedge-All® (and Tie-Wire) Anchors in Normal-Weight Concrete

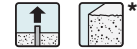

Size in. (mm)	Embed. Depth in. (mm)	Critical Edge Dist. in. (mm)	Critical Spacing in. (mm)	Tension Load							Install. Torque ft-lbs (N-m)
				f' _c ≥ 2000 psi (13.8 MPa) Concrete			f' _c ≥ 3000 psi (20.7 MPa) Concrete		f' _c ≥ 4000 psi (27.6 MPa) Concrete		
				Ultimate lbs. (kN)	Std. Dev. lbs. (kN)	Allowable lbs. (kN)	Allowable lbs. (kN)	Ultimate lbs. (kN)	Std. Dev. lbs. (kN)	Allowable lbs. (kN)	
1/4 (6.4)	1 1/8 (29)	2 1/2 (64)	1 5/8 (41)	680 (3.0)	167 (0.7)	170 (0.8)	205 (0.9)	960 (4.3)	233 (1.0)	240 (1.1)	8 (10.8)
	2 1/4 (57)	2 1/2 (64)	3 5/8 (79)	1,920 (8.5)	286 (1.3)	480 (2.1)	530 (2.4)	2,320 (10.3)	105 (0.5)	580 (2.6)	
3/8 (9.5)	1 3/4 (44)	3 3/4 (95)	2 5/8 (60)	1,560 (6.9)	261 (1.2)	390 (1.7)	555 (2.5)	2,880 (12.8)	588 (2.6)	720 (3.2)	30 (40.7)
	2 5/8 (67)	3 3/4 (95)	3 5/8 (92)	3,360 (14.9)	464 (2.1)	840 (3.7)	1,100 (4.9)	5,440 (24.2)	553 (2.5)	1,360 (6.0)	
	3 3/8 (86)	3 3/4 (95)	4 3/4 (121)	3,680 (16.4)	585 (2.6)	920 (4.1)	1,140 (5.1)	5,440 (24.2)	318 (1.4)	1,360 (6.0)	
1/2 (12.7)	2 1/4 (57)	5 (127)	3 5/8 (79)	3,280 (14.6)	871 (3.9)	820 (3.6)	1,070 (4.8)	5,280 (23.5)	849 (3.8)	1,320 (5.9)	60 (81.3)
	3 3/8 (86)	5 (127)	4 3/4 (121)	6,040 (26.9)	654 (2.9)	1,510 (6.7)	1,985 (8.8)	9,840 (43.8)	1,303 (5.8)	2,460 (10.9)	
	4 1/2 (114)	5 (127)	6 1/4 (159)	6,960 (31.0)	839 (3.7)	1,740 (7.7)	2,350 (10.5)	11,840 (52.7)	2,462 (11.0)	2,960 (13.2)	
5/8 (15.9)	2 3/4 (70)	6 1/4 (159)	3 5/8 (98)	4,520 (20.1)	120 (0.5)	1,130 (5.0)	1,640 (7.3)	8,600 (38.3)	729 (3.2)	2,150 (9.6)	90 (122.0)
	4 1/2 (114)	6 1/4 (159)	6 1/4 (159)	8,200 (36.5)	612 (2.7)	2,050 (9.1)	2,990 (13.3)	15,720 (69.9)	1,224 (5.4)	3,930 (17.5)	
	5 1/2 (140)	6 1/4 (159)	7 3/4 (197)	8,200 (36.5)	639 (2.8)	2,050 (9.1)	2,990 (13.3)	15,720 (69.9)	1,116 (5.0)	3,930 (17.5)	
3/4 (19.1)	3 3/8 (86)	7 1/2 (191)	4 3/4 (121)	6,760 (30.1)	1,452 (6.5)	1,690 (7.5)	2,090 (9.3)	9,960 (44.3)	1,324 (5.9)	2,490 (11.1)	150 (203.4)
	5 (127)	7 1/2 (191)	7 (178)	10,040 (44.7)	544 (2.4)	2,510 (11.2)	3,225 (14.3)	15,760 (70.1)	1,550 (6.9)	3,940 (17.5)	
	6 3/4 (171)	7 1/2 (191)	9 1/2 (241)	10,040 (44.7)	1,588 (7.1)	2,510 (11.2)	3,380 (15.0)	17,000 (75.6)	1,668 (7.4)	4,250 (18.9)	
7/8 (22.2)	3 3/8 (98)	8 3/4 (222)	5 5/8 (137)	7,480 (33.3)	821 (3.7)	1,870 (8.3)	2,275 (10.1)	10,720 (47.7)	1,253 (5.6)	2,680 (11.9)	200 (271.2)
	7 3/8 (200)	8 3/4 (222)	11 (279)	17,040 (75.8)	1,566 (7.0)	4,260 (18.9)	4,670 (20.8)	20,320 (90.4)	2,401 (10.7)	5,080 (22.6)	
1 (25.4)	4 1/2 (114)	10 (254)	6 1/4 (159)	15,400 (68.5)	2,440 (10.9)	3,850 (17.1)	3,885 (17.3)	15,680 (69.7)	1,876 (8.3)	3,920 (17.4)	300 (406.7)
	9 (229)	10 (254)	12 5/8 (321)	20,760 (92.3)	3,116 (13.9)	5,190 (23.1)	6,355 (28.3)	30,080 (133.8)	1,612 (7.2)	7,520 (33.5)	
1 1/4 (31.8)	5 5/8 (143)	12 1/2 (318)	7 3/8 (200)	15,160 (67.4)	1,346 (6.0)	3,790 (16.9)	4,990 (22.2)	24,760 (110.1)	625 (2.8)	6,190 (27.5)	400 (542.3)
	9 1/2 (241)	12 1/2 (318)	13 1/4 (337)	20,160 (89.7)	3,250 (14.5)	5,040 (22.4)	8,635 (38.4)	48,920 (217.6)	1,693 (7.5)	12,230 (54.4)	

1. The allowable loads listed are based on a safety factor of 4.0.
2. Refer to allowable load-adjustment factors for edge distance and spacing on pages 141 and 143.
3. Drill bit diameter used in base material corresponds to nominal anchor diameter.
4. Allowable loads may be linearly interpolated between concrete strengths listed.
5. Allowable loads for 1/4-inch size at 1 1/8-inch embedment apply to both the Wedge-All® and Tie-Wire anchors. Installation torque does not apply to the Tie-Wire anchor.
6. The minimum concrete thickness is 1 1/2 times the embedment depth.

*See page 13 for an explanation of the load table icons

Wedge-All® Wedge Anchors

Shear Loads for Carbon-Steel Wedge-All® (and Tie-Wire) Anchors in Normal-Weight Concrete



Size in. (mm)	Embed. Depth in. (mm)	Critical Edge Dist. in. (mm)	Critical Spacing in. (mm)	Shear Load					Install. Torque ft-lbs (N-m)
				$f'_c \geq 2000$ psi (13.8 MPa) Concrete			$f'_c \geq 3000$ psi (20.7 MPa) Concrete	$f'_c \geq 4000$ psi (27.6 MPa) Concrete	
				Ultimate lbs. (kN)	Std. Dev. lbs. (kN)	Allowable lbs. (kN)	Allowable lbs. (kN)	Allowable lbs. (kN)	
1/4 (6.4)	1 1/8 (29)	2 1/2 (64)	1 1/8 (41)	920 (4.1)	47 (0.2)	230 (1.0)	230 (1.0)	230 (1.0)	8 (10.8)
	2 1/4 (57)	2 1/2 (64)	3 1/8 (79)	•	•	230 (1.0)	230 (1.0)	230 (1.0)	
3/8 (9.5)	1 3/4 (44)	3 3/4 (95)	2 3/8 (60)	2,280 (10.1)	96 (0.4)	570 (2.5)	570 (2.5)	570 (2.5)	30 (40.7)
	2 1/8 (67)	3 3/4 (95)	3 3/8 (92)	4,220 (18.8)	384 (1.7)	1,055 (4.7)	1,055 (4.7)	1,055 (4.7)	
	3 3/8 (86)	3 3/4 (95)	4 3/4 (121)	•	•	1,055 (4.7)	1,055 (4.7)	1,055 (4.7)	
1/2 (12.7)	2 1/4 (57)	5 (127)	3 1/8 (79)	6,560 (29.2)	850 (3.8)	1,345 (6.0)	1,485 (6.6)	1,625 (7.2)	60 (81.3)
	3 1/8 (86)	5 (127)	4 3/4 (121)	8,160 (36.3)	880 (3.9)	1,675 (7.5)	1,850 (8.2)	2,020 (9.0)	
	4 1/2 (114)	5 (127)	6 1/4 (159)	•	•	1,675 (7.5)	1,850 (8.2)	2,020 (9.0)	
5/8 (15.9)	2 3/4 (70)	6 1/4 (159)	3 3/8 (98)	8,720 (38.8)	1,699 (7.6)	1,620 (7.2)	1,900 (8.5)	2,180 (9.7)	90 (122.0)
	4 1/2 (114)	6 1/4 (159)	6 1/4 (159)	12,570 (55.9)	396 (1.8)	2,330 (10.4)	2,740 (12.2)	3,145 (14.0)	
	5 1/2 (140)	6 1/4 (159)	7 3/4 (197)	•	•	2,330 (10.4)	2,740 (12.2)	3,145 (14.0)	
3/4 (19.1)	3 3/8 (86)	7 1/2 (191)	4 3/4 (121)	11,360 (50.5)	792 (3.5)	2,840 (12.6)	2,840 (12.6)	2,840 (12.6)	150 (203.4)
	5 (127)	7 1/2 (191)	7 (178)	18,430 (82.0)	1,921 (8.5)	4,610 (20.5)	4,610 (20.5)	4,610 (20.5)	
	6 3/4 (171)	7 1/2 (191)	9 1/2 (241)	•	•	4,610 (20.5)	4,610 (20.5)	4,610 (20.5)	
7/8 (22.2)	3 3/8 (98)	8 3/4 (222)	5 3/8 (137)	13,760 (61.2)	2,059 (9.2)	3,440 (15.3)	3,440 (15.3)	3,440 (15.3)	200 (271.2)
	7 3/8 (200)	8 3/4 (222)	11 (279)	22,300 (99.2)	477 (2.1)	5,575 (24.8)	5,575 (24.8)	5,575 (24.8)	
1 (25.4)	4 1/2 (114)	10 (254)	6 3/4 (159)	22,519 (100.2)	1,156 (5.1)	5,730 (25.5)	5,730 (25.5)	5,730 (25.5)	300 (406.7)
	9 (229)	10 (254)	12 5/8 (321)	25,380 (112.9)	729 (3.2)	6,345 (28.2)	6,345 (28.2)	6,345 (28.2)	
1 1/4 (31.8)	5 3/8 (143)	12 1/2 (318)	7 3/4 (200)	29,320 (130.4)	2,099 (9.3)	7,330 (32.6)	7,330 (32.6)	7,330 (32.6)	400 (542.3)
	9 1/2 (241)	12 1/2 (318)	13 1/4 (337)	•	•	7,330 (32.6)	7,330 (32.6)	7,330 (32.6)	

- The allowable loads listed are based on a safety factor of 4.0.
- Refer to allowable load-adjustment factors for spacing and edge distance on pages 141, 142 and 144.
- Drill bit diameter used in base material corresponds to nominal anchor diameter.
- Allowable loads may be linearly interpolated between concrete strengths listed.
- Allowable loads for 1/4-inch size at 1 1/8-inch embedment apply to both the Wedge-All® and Tie-Wire anchors. Installation torque does not apply to the Tie-Wire anchor.
- The minimum concrete thickness is 1 1/2 times the embedment depth.

*See page 13 for an explanation of the load table icons

Wedge-All® Wedge Anchors

Tension Loads for Stainless-Steel Wedge-All® Anchors in Normal-Weight Concrete

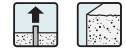

*See page 13 for an explanation of the load table icons

Size in. (mm)	Embed. Depth in. (mm)	Critical Edge Dist. in. (mm)	Critical Spacing in. (mm)	Allowable Tension Load lbs. (kN)			Install. Torque ft-lbs (N-m)
				f' _c ≥ 2000 psi (13.8 MPa) Concrete	f' _c ≥ 3000 psi (20.7 MPa) Concrete	f' _c ≥ 4000 psi (27.6 MPa) Concrete	
1/4 (6.4)	1 1/8 (29)	2 1/2 (64)	1 1/8 (41)	155 (0.7)	185 (0.8)	215 (1.0)	8 (10.8)
	2 1/4 (57)	2 1/2 (64)	3 1/8 (79)	430 (1.9)	475 (2.1)	520 (2.3)	
3/8 (9.5)	1 3/4 (44)	3 3/4 (95)	2 3/8 (60)	350 (1.6)	500 (2.2)	650 (2.9)	30 (40.7)
	2 5/8 (67)	3 3/4 (95)	3 3/8 (92)	755 (3.4)	990 (4.4)	1,225 (5.4)	
	3 3/8 (86)	3 3/4 (95)	4 3/4 (121)	830 (3.7)	1,025 (4.6)	1,225 (5.4)	
1/2 (12.7)	2 3/4 (57)	5 (127)	3 3/8 (79)	740 (3.3)	965 (4.3)	1,190 (5.3)	60 (81.3)
	3 3/8 (86)	5 (127)	4 3/4 (121)	1,360 (6.0)	1,785 (7.9)	2,215 (9.9)	
	4 1/2 (114)	5 (127)	6 1/4 (159)	1,565 (7.0)	2,115 (9.4)	2,665 (11.9)	
5/8 (15.9)	2 3/4 (70)	6 1/4 (159)	3 3/8 (98)	1,015 (4.5)	1,475 (6.6)	1,935 (8.6)	90 (122.0)
	4 1/2 (114)	6 1/4 (159)	6 1/4 (159)	1,845 (8.2)	2,690 (12.0)	3,535 (15.7)	
	5 1/2 (140)	6 1/4 (159)	7 3/4 (197)	1,845 (8.2)	2,690 (12.0)	3,535 (15.7)	
3/4 (19.1)	3 3/8 (86)	7 1/2 (191)	4 3/4 (121)	1,520 (6.8)	1,880 (8.4)	2,240 (10.0)	150 (203.4)
	5 (127)	7 1/2 (191)	7 (178)	2,260 (10.1)	2,905 (12.9)	3,545 (15.8)	
	6 3/4 (171)	7 1/2 (191)	9 1/2 (241)	2,260 (10.1)	3,040 (13.5)	3,825 (17.0)	
7/8 (22.2)	3 3/8 (98)	8 3/4 (222)	5 3/8 (137)	1,685 (7.5)	2,050 (9.1)	2,410 (10.7)	200 (271.2)
	7 7/8 (200)	8 3/4 (222)	11 (279)	3,835 (17.1)	4,205 (18.7)	4,570 (20.3)	
1 (25.4)	4 1/2 (114)	10 (254)	6 3/4 (159)	3,465 (15.4)	3,495 (15.5)	3,530 (15.7)	300 (406.7)
	9 (229)	10 (254)	12 3/8 (321)	4,670 (20.8)	5,720 (25.4)	6,770 (30.1)	
1 1/4 (31.8)	5 3/8 (143)	12 1/2 (318)	7 3/8 (200)	3,410 (15.2)	4,490 (20.0)	5,570 (24.8)	400 (542.3)
	9 1/2 (241)	12 1/2 (318)	13 1/4 (337)	4,535 (20.2)	7,770 (34.6)	11,005 (49.0)	

1. The allowable loads listed are based on a safety factor of 4.0.
2. Refer to allowable load-adjustment factors for edge distance and spacing on pages 141 and 143.
3. Drill bit diameter used in base material corresponds to nominal anchor diameter.
4. Allowable loads may be linearly interpolated between concrete strengths listed.
5. The minimum concrete thickness is 1 1/2 times the embedment depth.

Wedge-All® Wedge Anchors

Shear Loads for Stainless-Steel Wedge-All® Anchors
in Normal-Weight Concrete

Size in. (mm)	Embed. Depth in. (mm)	Critical Edge Dist. in. (mm)	Critical Spacing in. (mm)	Allowable Shear Load lbs. (kN)			Install. Torque ft-lbs (N-m)
				f' _c ≥ 2000 psi (13.8 MPa) Concrete	f' _c ≥ 3000 psi (20.7 MPa) Concrete	f' _c ≥ 4000 psi (27.6 MPa) Concrete	
1/4 (6.4)	1 1/8 (29)	2 1/2 (64)	1 1/8 (41)	265 (1.2)	265 (1.2)	265 (1.2)	8 (10.8)
	2 1/4 (57)	2 1/2 (64)	3 1/8 (79)	265 (1.2)	265 (1.2)	265 (1.2)	
3/8 (9.5)	1 3/8 (44)	3 3/4 (95)	2 3/8 (60)	655 (2.9)	655 (2.9)	655 (2.9)	30 (40.7)
	2 3/8 (67)	3 3/4 (95)	3 3/8 (92)	1,215 (5.4)	1,215 (5.4)	1,215 (5.4)	
	3 3/8 (86)	3 3/4 (95)	4 3/8 (121)	1,215 (5.4)	1,215 (5.4)	1,215 (5.4)	
1/2 (12.7)	2 1/4 (57)	5 (127)	3 1/8 (79)	1,545 (6.9)	1,710 (7.6)	1,870 (8.3)	60 (81.3)
	3 3/8 (86)	5 (127)	4 3/8 (121)	1,925 (8.6)	2,130 (9.5)	2,325 (10.3)	
	4 1/2 (114)	5 (127)	6 1/4 (159)	1,925 (8.6)	2,130 (9.5)	2,325 (10.3)	
5/8 (15.9)	2 3/4 (70)	6 1/4 (159)	3 3/8 (98)	1,865 (8.3)	2,185 (9.7)	2,505 (11.1)	90 (122.0)
	4 1/2 (114)	6 1/4 (159)	6 1/4 (159)	2,680 (11.9)	3,150 (14.0)	3,615 (16.1)	
	5 1/2 (140)	6 1/4 (159)	7 3/4 (197)	2,680 (11.9)	3,150 (14.0)	3,615 (16.1)	
3/4 (19.1)	3 3/8 (86)	7 1/2 (191)	4 3/8 (121)	3,265 (14.5)	3,265 (14.5)	3,265 (14.5)	150 (203.4)
	5 (127)	7 1/2 (191)	7 (178)	5,300 (23.6)	5,300 (23.6)	5,300 (23.6)	
	6 3/4 (171)	7 1/2 (191)	9 1/2 (241)	5,300 (23.6)	5,300 (23.6)	5,300 (23.6)	
7/8 (22.2)	3 3/8 (98)	8 3/4 (222)	5 3/8 (137)	3,955 (17.6)	3,955 (17.6)	3,955 (17.6)	200 (271.2)
	7 3/8 (200)	8 3/4 (222)	11 (279)	6,410 (28.5)	6,410 (28.5)	6,410 (28.5)	
1 (25.4)	4 1/2 (114)	10 (254)	6 1/4 (159)	6,590 (29.3)	6,590 (29.3)	6,590 (29.3)	300 (406.7)
	9 (229)	10 (254)	12 3/8 (321)	7,295 (32.4)	7,295 (32.4)	7,295 (32.4)	
1 1/4 (31.8)	5 3/8 (143)	12 1/2 (318)	7 3/8 (200)	8,430 (37.5)	8,430 (37.5)	8,430 (37.5)	400 (542.3)
	9 1/2 (241)	12 1/2 (318)	13 1/4 (337)	8,430 (37.5)	8,430 (37.5)	8,430 (37.5)	

*See page 13 for an explanation of the load table icons

1. The allowable loads listed are based on a safety factor of 4.0.
2. Refer to allowable load-adjustment factors for spacing and edge distance on pages 141, 142 and 144.
3. Drill bit diameter used in base material corresponds to nominal anchor diameter.
4. Allowable loads may be linearly interpolated between concrete strengths listed.
5. The minimum concrete thickness is 1 1/2 times the embedment depth.

Wedge-All® Wedge Anchors

Tension Loads for Carbon-Steel Wedge-All® (and Tie-Wire) Anchors in Sand-Lightweight Concrete over Metal Deck



Size in. (mm)	Embed. Depth in. (mm)	Critical Edge Dist. in. (mm)	Critical Spacing in. (mm)	Tension Load (Install in Concrete)			Tension Load (Install through Metal Deck)			Install. Torque ft-lbs (N-m)
				f'c ≥ 3000 psi (20.7 MPa) Concrete			f'c ≥ 3000 psi (20.7 MPa) Concrete			
				Ultimate lbs. (kN)	Std. Dev. lbs. (kN)	Allow. lbs. (kN)	Ultimate lbs. (kN)	Std. Dev. lbs. (kN)	Allow. lbs. (kN)	
1/4 (TWD) (6.4)	1 1/2 (38)	3 3/8 (86)	2 3/4 (70)	—	—	—	1,440 (6.4)	167 (0.7)	360 (1.6)	—
1/2 (12.7)	2 1/4 (57)	6 3/4 (171)	4 1/2 (105)	3,880 (17.3)	228 (1.0)	970 (4.3)	3,860 (17.2)	564 (2.5)	965 (4.3)	60 (81.3)
5/8 (15.9)	2 3/4 (70)	8 3/8 (213)	5 (127)	5,920 (26.3)	239 (1.1)	1,480 (6.6)	5,220 (23.2)	370 (1.6)	1,305 (5.8)	90 (122.0)
3/4 (19.1)	3 3/8 (>86)	10 (254)	6 1/8 (156)	7,140 (31.8)	537 (2.4)	1,785 (7.9)	6,600 (29.4)	903 (4.0)	1,650 (7.3)	150 (203.4)

* See page 13 for an explanation of the load table icons

See Notes 1–8 Below

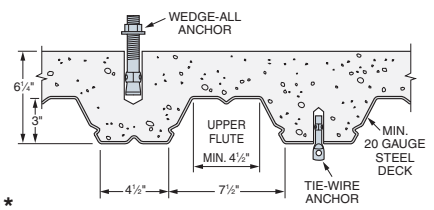

Lightweight Concrete On Metal Deck

Shear Loads for Carbon-Steel Wedge-All® (and Tie-Wire) Anchors in Sand-Lightweight Concrete over Metal Deck



Size in. (mm)	Embed. Depth in. (mm)	Critical Edge Dist. in. (mm)	Critical Spacing in. (mm)	Shear Load (Install in Concrete)			Shear Load (Install through Metal Deck)			Install. Torque ft-lbs (N-m)
				f'c ≥ 3000 psi (20.7 MPa) Concrete			f'c ≥ 3000 psi (20.7 MPa) Concrete			
				Ultimate lbs. (kN)	Std. Dev. lbs. (kN)	Allow. lbs. (kN)	Ultimate lbs. (kN)	Std. Dev. lbs. (kN)	Allow. lbs. (kN)	
1/4 (TWD) (6.4)	1 1/2 (38)	3 3/8 (86)	2 3/4 (70)	—	—	—	1,660 (7.4)	627 (2.8)	415 (1.8)	—
1/2 (12.7)	2 1/4 (57)	6 3/4 (171)	4 1/2 (105)	5,575 (24.8)	377 (1.7)	1,395 (6.2)	7,260 (32.3)	607 (2.7)	1,815 (8.1)	60 (81.3)
5/8 (15.9)	2 3/4 (70)	8 3/8 (213)	5 (127)	8,900 (39.6)	742 (3.3)	2,225 (9.9)	8,560 (38.1)	114 (0.5)	2,140 (9.5)	90 (122.0)
3/4 (19.1)	3 3/8 (86)	10 (254)	6 1/8 (156)	10,400 (46.3)	495 (2.2)	2,600 (11.6)	11,040 (49.1)	321 (1.4)	2,760 (12.3)	150 (203.4)

- The allowable loads listed are based on a safety factor of 4.0.
- Refer to allowable load-adjustment factors for edge distance on page 148.
- 100% of the allowable load is permitted at critical spacing, loads at reduced spacing have not been determined.
- Drill bit diameter used in base material corresponds to nominal anchor diameter.
- The minimum concrete thickness is 1 1/2 times the embedment depth.
- Metal deck must be minimum 20 gauge.
- Anchors installed in the bottom flute of the steel deck must have a minimum allowable edge distance of 1 1/2" from the inclined edge of the bottom flute.

Mechanical Anchors

Tension and Shear Loads for Carbon-Steel Wedge-All® Anchors in Grout-Filled CMU



Size in. (mm)	Embed. Depth in. (mm)	Critical Edge Dist. in. (mm)	Critical End Dist. in. (mm)	Critical Spacing in. (mm)	8" Grout-Filled CMU Allowable Load Based on CMU Strength						Install. Torque ft-lbs (N-m)
					Tension Load			Shear Load			
					Ultimate lbs. (kN)	Std. Dev. lbs. (kN)	Allow. lbs. (kN)	Ultimate lbs. (kN)	Std. Dev. lbs. (kN)	Allow. lbs. (kN)	
Anchor Installed on the Face of the CMU Wall at Least 1 1/4 inch Away from Head Joint (See Figure)											
3/8 (9.5)	2 5/8 (67)	10 1/2 (267)	10 1/2 (267)	10 1/2 (267)	1,700 (7.6)	129 (0.6)	340 (1.5)	3,360 (14.9)	223 (1.0)	670 (3.0)	30 (40.7)
1/2 (12.7)	3 1/2 (89)	14 (356)	14 (356)	14 (356)	2,120 (9.4)	129 (0.6)	425 (1.9)	5,360 (23.8)	617 (2.7)	1,070 (4.8)	35 (47.4)
5/8 (15.9)	4 3/8 (111)	17 1/2 (445)	17 1/2 (445)	17 1/2 (445)	3,120 (13.9)	342 (1.5)	625 (2.8)	8,180 (36.4)	513 (2.3)	1,635 (7.3)	55 (74.5)
3/4 (19.1)	5 1/4 (133)	21 (533)	21 (533)	21 (533)	4,320 (19.2)	248 (1.1)	865 (3.8)	10,160 (45.2)	801 (3.6)	2,030 (9.0)	120 (162.6)

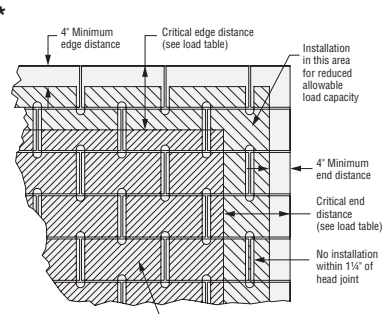

Shaded Area = Placement for Full and Reduced Allowable Load Capacity in Grout-Filled CMU

- The tabulated allowable loads are based on a safety factor of 5.0 for installations under the IBC and IRC.
- Listed loads may be applied to installations on the face of the CMU wall at least 1 1/4 inch away from headjoints.
- Values for 8-inch wide concrete masonry units (CMU) with a minimum specified compressive strength of masonry, f'm, at 28 days is 1500 psi.
- Embedment depth is measured from the outside face of the concrete masonry unit.
- Drill bit diameter used in base material corresponds to nominal anchor diameter.
- Allowable loads may be increased 33 1/3 % for short-term loading due to wind and seismic forces.
- Tension and shear loads for the Wedge-All® anchor may be combined using the parabolic interaction equation (n=5%).
- Refer to allowable load-adjustment factors for edge distance on page 145.

Wedge-All® Technical Information

Load-Adjustment Factors for Carbon-Steel and Stainless-Steel Wedge-All® Anchors in Normal-Weight Concrete: Edge Distance, Tension and Shear Loads

How to use these charts:

1. The following tables are for reduced edge distance.
2. Locate the anchor size to be used for either a tension and/or shear load application.
3. Locate the edge distance (C_{act}) at which the anchor is to be installed.
4. The load adjustment factor (f_c) is the intersection of the row and column.
5. Multiply the allowable load by the applicable load adjustment factor.
6. Reduction factors for multiple edges are multiplied together.

Edge Distance Tension (f_c)



Edge Dist. C_{act} (in.)	Size	1/4	3/8	1/2	5/8	3/4	7/8	1	1 1/4
	C_{cr}	2 1/2	3 3/4	5	6 1/4	7 1/2	8 3/4	10	12 1/2
	C_{min}	1	1 1/2	2	2 1/2	3	3 1/2	4	5
	f_{cmin}	0.70	0.70	0.70	0.70	0.70	0.70	0.70	0.70
1		0.70							
1 1/2		0.80	0.70						
2		0.90	0.77	0.70					
2 1/2		1.00	0.83	0.75	0.70				
3			0.90	0.80	0.74	0.70			
3 1/2			0.97	0.85	0.78	0.73	0.70		
3 3/4			1.00	0.88	0.80	0.75	0.71		
4				0.90	0.82	0.77	0.73	0.70	
4 1/2				0.95	0.86	0.80	0.76	0.73	
5				1.00	0.90	0.83	0.79	0.75	0.70
5 1/2					0.94	0.87	0.81	0.78	0.72
6					0.98	0.90	0.84	0.80	0.74
6 1/4					1.00	0.92	0.86	0.81	0.75
6 1/2						0.93	0.87	0.83	0.76
7						0.97	0.90	0.85	0.78
7 1/2						1.00	0.93	0.88	0.80
8							0.96	0.90	0.82
8 1/2							0.99	0.93	0.84
8 3/4							1.00	0.94	0.85
10								1.00	0.90
12 1/2									1.00
15									

*See page 13 for an explanation of the load table icons

See Notes Below

Edge Distance Shear (f_c) (Shear Applied Perpendicular to Edge)



Edge Dist. C_{act} (in.)	Size	1/4	3/8	1/2	5/8	3/4	7/8	1	1 1/4
	C_{cr}	2 1/2	3 3/4	5	6 1/4	7 1/2	8 3/4	10	12 1/2
	C_{min}	1	1 1/2	2	2 1/2	3	3 1/2	4	5
	f_{cmin}	0.30	0.30	0.30	0.30	0.30	0.30	0.30	0.30
1		0.30							
1 1/2		0.53	0.30						
2		0.77	0.46	0.30					
2 1/2		1.00	0.61	0.42	0.30				
3			0.77	0.53	0.39	0.30			
3 1/2			0.92	0.65	0.49	0.38	0.30		
3 3/4			1.00	0.71	0.53	0.42	0.33		
4				0.77	0.58	0.46	0.37	0.30	
4 1/2				0.88	0.67	0.53	0.43	0.36	
5				1.00	0.77	0.61	0.50	0.42	0.30
5 1/2					0.86	0.69	0.57	0.48	0.35
6					0.95	0.77	0.63	0.53	0.39
6 1/4					1.00	0.81	0.67	0.56	0.42
6 1/2						0.84	0.70	0.59	0.44
7						0.92	0.77	0.65	0.49
7 1/2						1.00	0.83	0.71	0.53
8							0.90	0.77	0.58
8 1/2							0.97	0.83	0.63
8 3/4							1.00	0.85	0.65
10								1.00	0.77
12 1/2									1.00
15									

1. C_{act} = actual edge distance at which anchor is installed (inches).
2. C_{cr} = critical edge distance for 100% load (inches).
3. C_{min} = minimum edge distance for reduced load (inches).
4. f_c = adjustment factor for allowable load at actual edge distance.
5. $f_{c cr}$ = adjustment factor for allowable load at critical edge distance. $f_{c cr}$ is always = 1.00.
6. $f_{c min}$ = adjustment factor for allowable load at minimum edge distance.
7. $f_c = f_{c min} + [(1 - f_{c min}) (C_{act} - C_{min}) / (C_{cr} - C_{min})]$.

Load-Adjustment Factors for Reduced Spacing:

Critical spacing is listed in the load tables. No adjustment in load is required when the anchors are spaced at critical spacing. No additional testing has been performed to determine the adjustment factors for spacing dimensions less than those listed in the load tables.

Wedge-All® Technical Information

Load-Adjustment Factors for Carbon-Steel and Stainless-Steel Wedge-All® Anchors in Normal-Weight Concrete: Edge Distance and Shear Load Applied Parallel to Edge

How to use these charts:

1. The following tables are for reduced edge distance.
2. Locate the anchor size to be used for a shear load application.
3. Locate the edge distance ($C_{act||}$) at which the anchor is to be installed.
4. The load adjustment factor ($f_{c||}$) is the intersection of the row and column.
5. Multiply the allowable load by the applicable load adjustment factor.
6. Reduction factors for multiple edges are multiplied together.

**Edge Distance Shear ($f_{c||}$)
(Shear Applied Parallel to Edge
with End Distance $\geq ED_{min}$)**



Edge Dist. $C_{act }$ (in.)	Size	1/4	3/8	1/2	5/8	3/4	7/8	1	1 1/4
	E	2 1/4	3 3/8	4 1/2	5 1/2	6 3/4	7 7/8	9	9 1/2
	ED_{min}	9	13 1/2	18	22	27	31 1/2	36	38
	$C_{cr }$	2 1/2	3 3/4	5	6 1/4	7 1/2	8 3/4	10	12 1/2
	$C_{min }$	1	1 1/2	2	2 1/2	3	3 1/2	4	5
$f_{cmin }$	1.00	0.93	0.70	0.62	0.62	0.62	0.62	0.62	0.62
1		1.00							
1 1/2		1.00	0.93						
2		1.00	0.95	0.70					
2 1/2		1.00	0.96	0.75	0.62				
3			0.98	0.80	0.67	0.62			
3 1/2			0.99	0.85	0.72	0.66	0.62		
4			1.00	0.90	0.77	0.70	0.66	0.62	
5				1.00	0.87	0.79	0.73	0.68	0.62
6					0.97	0.87	0.80	0.75	0.67
7					1.00	0.96	0.87	0.81	0.72
8						1.00	0.95	0.87	0.77
9							1.00	0.94	0.82
10								1.00	0.87
11									0.92
12									0.97
13									1.00

* See page 13 for an explanation of the load table icons

Mechanical Anchors

1. Table is not applicable to anchors with $ED < ED_{min}$. Factors from this table may not be combined with load-adjustment factors for shear loads applied perpendicular to edge.
2. $C_{act||}$ = actual edge distance (measured perpendicular to direction of shear load) at which anchor is installed (inches).
3. $C_{cr||}$ = critical edge distance (measured perpendicular to direction of shear load) for 100% load (inches).
4. $C_{min||}$ = minimum edge distance (measured perpendicular to direction of shear load) for reduced load (inches).
5. ED = actual end distance (measured parallel to direction of shear load) at which anchor is installed (inches).
6. ED_{min} = minimum edge distance (measured parallel to direction of shear load).
7. $f_{c||}$ = adjustment factor for allowable load at actual edge distance.
8. $f_{ccr||}$ = adjustment factor for allowable load at critical edge distance. $f_{ccr||}$ is always = 1.00.
9. $f_{cmin||}$ = adjustment factor for allowable load at minimum edge distance.
10. $f_{c||} = f_{cmin||} + [(1 - f_{cmin||}) (C_{act||} - C_{min||}) / (C_{cr||} - C_{min||})]$.

Wedge-All® Technical Information

Load-Adjustment Factors for Carbon-Steel and Stainless-Steel Wedge-All® Anchors in Normal-Weight Concrete: Spacing, Tension Loads

How to use these charts:

1. The following tables are for reduced spacing.
2. Locate the anchor size to be used for a tension load application.
3. Locate the anchor embedment (E) used for a tension load application.
4. Locate the spacing (S_{act}) at which the anchor is to be installed.
5. The load adjustment factor (f_s) is the intersection of the row and column.
6. Multiply the allowable load by the applicable load adjustment factor.
7. Reduction factors for multiple spacings are multiplied together.

Spacing Tension (f_s)



S_{act} (in.)	Dia.	1/4		3/8			1/2			5/8		
	E	1 1/8	2 1/4	1 3/4	2 5/8	3 3/8	2 1/4	3 3/8	4 1/2	2 3/4	4 1/2	5 1/2
	S_{cr}	1 5/8	3 1/8	2 3/8	3 3/8	4 3/4	3 1/8	4 3/4	6 1/4	3 3/8	6 1/4	7 3/4
	S_{min}	5/8	1 1/8	7/8	1 1/8	1 3/4	1 1/8	1 3/4	2 1/4	1 3/8	2 1/4	2 3/4
	f_{smin}	0.43	0.70	0.43	0.43	0.70	0.43	0.43	0.70	0.43	0.43	0.70
3/4		0.50										
1		0.64		0.48								
1 1/4		0.79	0.72	0.57			0.47					
1 1/2		0.93	0.76	0.67	0.46		0.54			0.46		
1 3/4		1.00	0.79	0.76	0.53	0.70	0.61	0.43		0.52		
2			0.83	0.86	0.59	0.73	0.68	0.48		0.57		
2 1/4			0.87	0.95	0.65	0.75	0.75	0.53	0.70	0.63	0.43	
2 1/2			0.91	1.00	0.72	0.78	0.82	0.57	0.72	0.69	0.47	
2 3/4			0.94		0.78	0.80	0.89	0.62	0.74	0.74	0.50	0.70
3			0.98		0.84	0.83	0.96	0.67	0.76	0.80	0.54	0.72
3 1/2			1.00		0.97	0.88	1.00	0.76	0.79	0.91	0.61	0.75
4					1.00	0.93		0.86	0.83	1.00	0.68	0.78
4 1/2						0.98		0.95	0.87		0.75	0.81
5						1.00		1.00	0.91		0.82	0.84
6									0.98		0.96	0.90
7									1.00		1.00	0.96
8												1.00

*See page 13 for an explanation of the load table icons

See Notes Below

Spacing Tension (f_s)



S_{act} (in.)	Dia.	3/4			7/8		1		1 1/4	
	E	3 3/8	5	6 3/4	3 3/8	7 7/8	4 1/2	9	5 5/8	9 1/2
	S_{cr}	4 3/4	7	9 1/2	5 5/8	11	6 1/4	12 5/8	7 7/8	13 1/4
	S_{min}	1 3/4	2 1/2	3 3/8	2	4	2 1/4	4 1/2	2 7/8	4 3/4
	f_{smin}	0.43	0.43	0.70	0.43	0.70	0.43	0.70	0.43	0.70
2		0.48			0.43					
3		0.67	0.49		0.60		0.54		0.46	
4		0.86	0.62	0.73	0.77	0.70	0.68		0.57	
5		1.00	0.75	0.78	0.94	0.74	0.82	0.72	0.68	0.71
6			0.87	0.83	1.00	0.79	0.96	0.76	0.79	0.74
7			1.00	0.88		0.83	1.00	0.79	0.90	0.78
8				0.93		0.87		0.83	1.00	0.81
9				0.98		0.91		0.87		0.85
10				1.00		0.96		0.90		0.89
11						1.00		0.94		0.92
12								0.98		0.96
13								1.00		0.99
14										1.00

1. E = Embedment depth (inches).
2. S_{act} = actual spacing distance at which anchors are installed (inches).
3. S_{cr} = critical spacing distance for 100% load (inches).
4. S_{min} = minimum spacing distance for reduced load (inches).
5. f_s = adjustment factor for allowable load at actual spacing distance.
6. $f_{s cr}$ = adjustment factor for allowable load at critical spacing distance.
 $f_{s cr}$ is always = 1.00.
7. $f_{s min}$ = adjustment factor for allowable load at minimum spacing distance.
8. $f_s = f_{s min} + [(1 - f_{s min}) (S_{act} - S_{min}) / (S_{cr} - S_{min})]$.

Wedge-All® Technical Information

Load-Adjustment Factors for Carbon-Steel and Stainless-Steel Wedge-All® Anchors in Normal-Weight Concrete: Spacing, Shear Loads

How to use these charts:

1. The following tables are for reduced spacing.
2. Locate the anchor size to be used for a shear load application.
3. Locate the anchor embedment (E) used for a shear load application.
4. Locate the spacing (S_{act}) at which the anchor is to be installed.
5. The load adjustment factor (f_s) is the intersection of the row and column.
6. Multiply the allowable load by the applicable load adjustment factor.
7. Reduction factors for multiple spacings are multiplied together.

Spacing Shear (f_s)



S_{act} (in.)	Dia.	1/4		3/8			1/2			5/8		
	E	1 1/8	2 1/4	1 3/4	2 5/8	3 3/8	2 1/4	3 3/8	4 1/2	2 3/4	4 1/2	5 1/2
	S_{cr}	1 5/8	3 1/8	2 3/8	3 3/8	4 3/4	3 1/8	4 3/4	6 1/4	3 3/8	6 1/4	7 3/4
	S_{min}	5/8	1 1/8	7/8	1 3/8	1 3/4	1 1/8	1 3/4	2 1/4	1 3/8	2 1/4	2 3/4
	f_{smin}	0.79	0.79	0.79	0.79	0.79	0.79	0.79	0.79	0.79	0.79	0.79
3/4		0.82										
1		0.87		0.81								
1 1/4		0.92	0.80	0.84			0.80					
1 1/2		0.97	0.83	0.88	0.80		0.83			0.80		
1 3/4		1.00	0.86	0.91	0.83	0.79	0.86	0.79		0.82		
2			0.88	0.95	0.85	0.81	0.88	0.81		0.84		
2 1/4			0.91	0.98	0.87	0.83	0.91	0.83	0.79	0.86	0.79	
2 1/2			0.93	1.00	0.90	0.84	0.93	0.84	0.80	0.88	0.80	
2 3/4			0.96		0.92	0.86	0.96	0.86	0.82	0.91	0.82	0.79
3			0.99		0.94	0.88	0.99	0.88	0.83	0.93	0.83	0.80
3 1/2			1.00		0.99	0.91	1.00	0.91	0.86	0.97	0.86	0.82
4					1.00	0.95		0.95	0.88	1.00	0.88	0.84
4 1/2						0.98		0.98	0.91		0.91	0.86
5						1.00		1.00	0.93		0.93	0.88
6									0.99		0.99	0.93
7									1.00		1.00	0.97
8												1.00

*See page 13 for an explanation of the load table icons

See Notes Below

Mechanical Anchors

Spacing Shear (f_s)



S_{act} (in.)	Dia.	3/4		7/8		1		1 1/4		
	E	3 3/8	5	6 3/4	3 3/8	7 7/8	4 1/2	9	5 3/8	9 1/2
	S_{cr}	4 3/4	7	9 1/2	5 3/8	11	6 3/4	12 3/8	7 3/8	13 1/4
	S_{min}	1 3/4	2 1/2	3 3/8	2	4	2 1/4	4 1/2	2 3/8	4 3/4
	f_{smin}	0.79	0.79	0.79	0.79	0.79	0.79	0.79	0.79	0.79
2		0.81			0.79					
3		0.88	0.81		0.85		0.83		0.80	
4		0.95	0.86	0.81	0.91	0.79	0.88		0.84	
5		1.00	0.91	0.85	0.98	0.82	0.93	0.80	0.88	0.80
6			0.95	0.88	1.00	0.85	0.99	0.83	0.92	0.82
7			1.00	0.91		0.88	1.00	0.85	0.96	0.85
8				0.95		0.91		0.88	1.00	0.87
9				0.98		0.94		0.91		0.90
10				1.00		0.97		0.93		0.92
11						1.00		0.96		0.94
12								0.98		0.97
13								1.00		0.99
14										1.00



1. E = Embedment depth (inches).
2. S_{act} = actual spacing distance at which anchors are installed (inches).
3. S_{cr} = critical spacing distance for 100% load (inches).
4. S_{min} = minimum spacing distance for reduced load (inches).
5. f_s = adjustment factor for allowable load at actual spacing distance.
6. f_{scr} = adjustment factor for allowable load at critical spacing distance.
 f_{scr} is always = 1.00.
7. f_{smin} = adjustment factor for allowable load at minimum spacing distance.
8. $f_s = f_{smin} + [(1 - f_{smin}) (S_{act} - S_{min}) / (S_{cr} - S_{min})]$.

Wedge-All® Technical Information

Load-Adjustment Factors for Carbon-Steel Wedge-All® Anchors in Sand-Lightweight Concrete: Edge Distance, Tension and Shear Loads

How to use these charts:

1. The following tables are for reduced edge distance.
2. Locate the anchor size to be used for either a tension and/or shear load application.
3. Locate the edge distance (C_{act}) at which the anchor is to be installed.
4. The load adjustment factor (f_c) is the intersection of the row and column.
5. Multiply the allowable load by the applicable load adjustment factor.
6. Reduction factors for multiple edges are multiplied together.

Edge Distance Tension (f_c)   *

Edge Dist. C_{act} (in.)	Size	1/4	1/2	5/8	3/4
	C_{cr}	3 3/8	6 3/4	8 3/8	10
	C_{min}	1 3/8	2 3/4	3 3/8	4
	f_{cmin}	0.70	0.70	0.70	0.70
1 3/8		0.70			
1 1/2		0.72			
2		0.79			
2 1/2		0.87			
2 3/4		0.91	0.70		
3		0.94	0.72		
3 3/8		1.00	0.75	0.70	
3 1/2			0.76	0.71	
4			0.79	0.74	0.70
4 1/2			0.83	0.77	0.73
5			0.87	0.80	0.75
5 1/2			0.91	0.83	0.78
6			0.94	0.86	0.80
6 1/2			0.98	0.89	0.83
6 3/4			1.00	0.90	0.84
7				0.92	0.85
7 1/2				0.95	0.88
8				0.98	0.90
8 3/8				1.00	0.92
8 1/2					0.93
9					0.95
9 1/2					0.98
10					1.00

See Notes Below

Edge Distance Shear (f_c)
(Shear Applied Perpendicular to Edge)



Edge Dist. C_{act} (in.)	Size	1/4	1/2	5/8	3/4
	C_{cr}	3 3/8	6 3/4	8 3/8	10
	C_{min}	1 3/8	2 3/4	3 3/8	4
	f_{cmin}	0.30	0.30	0.30	0.30
1 3/8		0.30			
1 1/2		0.34			
2		0.52			
2 1/2		0.69			
2 3/4		0.78	0.30		
3		0.87	0.34		
3 3/8		1.00	0.41	0.30	
3 1/2			0.43	0.32	
4			0.52	0.39	0.30
4 1/2			0.61	0.46	0.36
5			0.69	0.53	0.42
5 1/2			0.78	0.60	0.48
6			0.87	0.67	0.53
6 1/2			0.96	0.74	0.59
6 3/4			1.00	0.77	0.62
7				0.81	0.65
7 1/2				0.88	0.71
8				0.95	0.77
8 3/8				1.00	0.81
8 1/2					0.83
9					0.88
9 1/2					0.94
10					1.00

See Notes Below





*See page 13 for an explanation of the load table icons

Load-Adjustment Factors for Carbon-Steel Wedge-All® Anchors in Face of Wall Installation in 8" Grout-Filled CMU: Edge Distance, Tension and Shear Loads

Edge Distance Tension (f_c)   *

Edge Dist. C_{act} (in.)	Size	3/8	1/2	5/8	3/4
	C_{cr}	12	12	20	20
	C_{min}	4	4	4	4
	f_{cmin}	1.00	1.00	0.80	0.80
4		1.00	1.00	0.80	0.80
6		1.00	1.00	0.83	0.83
8		1.00	1.00	0.85	0.85
10		1.00	1.00	0.88	0.88
12		1.00	1.00	0.90	0.90
14				0.93	0.93
16				0.95	0.95
18				0.98	0.98
20				1.00	1.00

Edge Distance Shear (f_c)   *

Edge Dist. C_{act} (in.)	Size	3/8	1/2	5/8	3/4
	C_{cr}	12	12	20	20
	C_{min}	4	4	4	4
	f_{cmin}	0.79	0.52	0.32	0.32
4		0.79	0.52	0.32	0.32
5		0.82	0.58	0.36	0.36
6		0.84	0.64	0.41	0.41
7		0.87	0.70	0.45	0.45
8		0.90	0.76	0.49	0.49
9		0.92	0.82	0.53	0.53
10		0.95	0.88	0.58	0.58
11		0.97	0.94	0.62	0.62
12		1.00	1.00	0.66	0.66
13				0.70	0.70
14				0.75	0.75
15				0.79	0.79
16				0.83	0.83
17				0.87	0.87
18				0.92	0.92
19				0.96	0.96
20				1.00	1.00

1. C_{act} = actual edge distance at which anchor is installed (inches).
2. C_{cr} = critical edge distance for 100% load (inches).
3. C_{min} = minimum edge distance for reduced load (inches).
4. f_c = adjustment factor for allowable load at actual edge distance.
5. $f_{c_{cr}}$ = adjustment factor for allowable load at critical edge distance. $f_{c_{cr}}$ is always = 1.00.
6. $f_{c_{min}}$ = adjustment factor for allowable load at minimum edge distance.
7. $f_c = f_{c_{min}} + [(1 - f_{c_{min}}) (C_{act} - C_{min}) / (C_{cr} - C_{min})]$.

Load-Adjustment Factors for Reduced Spacing:
Critical spacing is listed in the load tables. No adjustment in load is required when the anchors are spaced at critical spacing. No additional testing has been performed to determine the adjustment factors for spacing dimensions less than those listed in the load tables.

Sleeve-All® Sleeve Anchors

Sleeve-All® sleeve anchors are pre-assembled expanding sleeve anchors for use in all types of solid base materials. These anchors are available in acorn, hex, rod coupler, flat or round head styles for a wide range of applications.

MATERIAL: Carbon and stainless steel

FINISH: Carbon Steel: Zinc plated

INSTALLATION:

 Caution: Oversized holes will make it difficult to set the anchor and will reduce the anchor's load capacity.

- Drill a hole in the base material using a carbide drill bit the same diameter as the nominal diameter of the anchor to be installed. Drill the hole to the specified embedment depth and blow it clean using compressed air. Overhead installations need not be blown clean. Alternatively, drill the hole deep enough to accommodate embedment depth and dust from drilling.
- Place the anchor in the fixture and drive into the hole until the washer and nut are tight against fixture.
- Tighten to required installation torque.

CODES: Factory Mutual 3017082, 3026805, 3029959 and 3043442, 3/8"–3/4" dia.; Underwriters Laboratories File Ex3605, 3/8"–3/4" dia. Meets requirements of Federal Specifications A-A-1922A.

 The load tables list values based upon results from the most recent testing and may not reflect those in the current code reports. Where code jurisdictions apply, consult the current reports for applicable load values.

SUGGESTED SPECIFICATIONS:

Sleeve anchors shall be zinc plated studs having a minimum 50,000 psi tensile strength with an expansion sleeve meeting AISI 1008 cold rolled steel or type 304 stainless steel stud with a type 304 stainless-steel expansion sleeve, as called for on the drawings. Sleeve anchors shall meet Federal Specifications A-A-1922A. Anchors shall be Sleeve-All® expanding sleeve anchors from Simpson Strong-Tie, Pleasanton, CA. Anchors shall be installed following the Simpson Strong-Tie instructions for Sleeve-All expanding sleeve anchors.

SLEEVE-ALL ANCHORS



Acorn



Hex



Phillips Flat Head



Round



Rod Coupler



Mechanical Anchors

Sleeve-All Anchor Installation Sequence

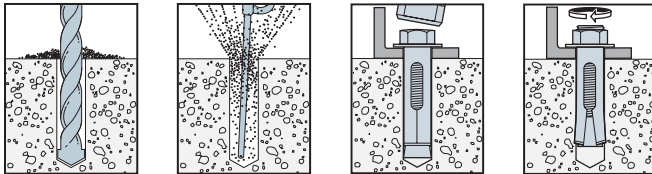

Material Specifications

Anchor Component	Zinc Plated Carbon Steel	304 Stainless Steel
Anchor Body	Material meets minimum 50,000 psi tensile	Type 304
Sleeve	SAE J403, Grade 1008 Cold Rolled Steel	Type 304
Nut	Commercial Grade, meets requirements of ASTM A563 Grade A	Type 304
Washer	SAE J403, Grade 1008/1010 Cold Rolled Steel	Type 304

Sleeve-All® Anchor Installation Data

Sleeve-All Dia. (in.)	1/4	5/16	3/8	1/2	5/8	3/4
Bit Size (in.)	1/4	5/16	3/8	1/2	5/8	3/4
Wrench Size ¹ (in.)	3/8	7/16	1/2	9/16	3/4	15/16
Wrench Size for Coupler Nut (in.)			1/2	5/8	3/4	–

1. Applies to Acorn and Hex head configurations only.

Length Identification Head Marks on Sleeve-All Anchors (corresponds to length of anchor – inches).

Mark	A	B	C	D	E	F	G	H	I	J	K	L	M	N	O	P	Q	R	S	T	U	V	W	X	Y	Z
From	1 1/2	2	2 1/2	3	3 1/2	4	4 1/2	5	5 1/2	6	6 1/2	7	7 1/2	8	8 1/2	9	9 1/2	10	11	12	13	14	15	16	17	18
Up To But Not Including	2	2 1/2	3	3 1/2	4	4 1/2	5	5 1/2	6	6 1/2	7	7 1/2	8	8 1/2	9	9 1/2	10	11	12	13	14	15	16	17	18	19

Sleeve-All® Sleeve Anchors

Sleeve-All® Anchor Product Data - Zinc-Plated Carbon Steel

Size (in.)	Model No.	Head Style	Bolt Diameter - Threads per inch	Max. Fixture Thickness (in.)	Quantity		
					Box	Ctn.	
1/4 x 1 3/8	SL25138A	Acorn Head	3/16 - 24	1/4	100	500	
1/4 x 2 1/4	SL25214A			1 1/8	100	500	
5/16 x 1 1/2*	SL31112H	Hex Head	1/4 - 20	3/8	100	500	
5/16 x 2 1/2	SL31212H			1 1/16	50	250	
3/8 x 1 1/8	SL37178H			3/8	50	250	
3/8 x 3	SL37300H			1 1/2	50	200	
3/8 x 4	SL37400H			2 1/4	50	200	
1/2 x 2 1/4*	SL50214H		1/2	50	200		
1/2 x 3	SL50300H		3/4	25	100		
1/2 x 4	SL50400H		1 3/4	25	100		
1/2 x 6	SL50600H		3 3/8	20	80		
5/8 x 2 1/4*	SL62214H		1/2	25	100		
5/8 x 3	SL62300H	1/2 - 13	3/4	20	80		
5/8 x 4 1/4	SL62414H		1 1/2	10	40		
5/8 x 6	SL62600H		3 1/4	10	40		
3/4 x 2 1/2*	SL75212H		1/2	10	40		
3/4 x 4 1/4	SL75414H		7/8	10	40		
3/4 x 6 1/4	SL75614H	2 7/8	5	20			
1/4 x 2	SL25200PF	Phillips Flat Head	3/16 - 24	7/8	100	500	
1/4 x 3	SL25300PF			1 7/8	50	250	
5/16 x 2 1/2	SL31212PF		1/4 - 20	1 1/16	50	250	
5/16 x 3 1/2	SL31312PF			2 1/16	50	250	
3/8 x 2 3/4	SL37234PF		5/16 - 18	1 1/4	50	200	
3/8 x 4	SL37400PF			2 1/2	50	200	
3/8 x 5	SL37500PF			3 1/2	50	200	
3/8 x 6	SL37600PF			4 1/2	50	200	
1/4 x 2	SL25200R			Round Head	3/16 - 24	7/8	100
1/4 x 2 3/4	SL25234R		1 5/8			50	250
3/8 x 2 1/2	SL37212R	1	50		200		
3/8 x 3 3/4	SL37334R	2 1/4	50		200		
3/8 x 4 3/4	SL37434R	3 1/4	50		200		

*These models do not meet minimum embedment requirements for rated load values.

Sleeve-All® Anchor Product Data - Stainless Steel

Size (in.)	Model No.	Head Style	Bolt Diameter - Threads per inch	Max. Fixture Thickness (in.)	Quantity	
					Box	Ctn.
1/4 x 2 1/4	SL2514PFSS	Phillips Flat Head	3/16 - 24	1 1/8	100	500
3/8 x 1 1/8	SL37178HSS			3/8	50	250
3/8 x 3	SL37300HSS	Hex Head	5/16 - 18	1 1/2	50	200
1/2 x 3	SL50300HSS			3/4	25	100
1/2 x 4	SL50400HSS			1 3/4	25	100

Sleeve-All® Anchor (with rod coupler) Product Data - Zinc-Plated Carbon Steel

Size (in.)	Model No.	Accepts Rod Dia. (in.)	Wrench Size	Quantity	
				Box	Ctn.
3/8 x 1 7/8	SL37178C	3/8	1/2	50	200
1/2 x 2 1/4	SL50214C	1/2	5/8	25	100
5/8 x 2 1/4	SL62214C	5/8	3/4	20	80

Tension and Shear Loads for 3/8" Sleeve-All® Anchor in Grout-Filled CMU (Anchor Installed in Horizontal Mortar Joint or Face Shell)

Size in. (mm)	Embed. Depth in. (mm)	Min. Edge Dist. in. (mm)	Min. End Dist. in. (mm)	Min. Spacing in. (mm)	Tension Load		Shear Load		Install. Torque ft-lbs (N-m)
					Ultimate lbs. (kN)	Allow. lbs. (kN)	Ultimate lbs. (kN)	Allow. lbs. (kN)	
3/8 (9.5)	1 1/2 (38)	16 (406)	16 (406)	24 (610)	2,000 (8.9)	400 (1.8)	2,300 (10.2)	460 (2.0)	15 (20)

- The tabulated allowable loads are based on a safety factor of 5.0 for installations under the IBC and IRC.
- Listed loads may be applied to installations through a face shell with the following placement guidelines:
 - Minimum 3" from vertical mortar joint.
 - Minimum 1" from vertical cell centerline.
- Values for 8-inch wide concrete masonry units (CMU) with a minimum specified compressive strength of masonry, f'_m , at 28 days is 1500 psi.
- Embedment depth is measured from the outside face of the concrete masonry unit.
- Drill bit diameter used in base material corresponds to nominal anchor diameter.
- Allowable loads may not be increased for short-term loading due to wind or seismic forces.



*See page 13 for an explanation of the load table icons

Face Shell Installation

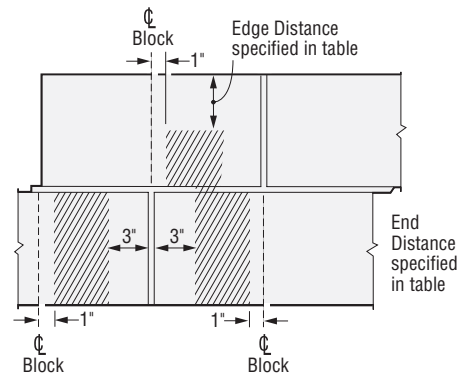

Allowable Anchor Placement in grout-filled CMU shown by shaded areas.

Sleeve-All® Sleeve Anchors

Tension and Shear Loads for Sleeve-All® Anchors in Normal-Weight Concrete



Size in. (mm)	Embed. Depth in. (mm)	Critical Edge Dist. in. (mm)	Critical Spacing Dist. in. (mm)	Tension Load						Shear Load			Install. Torque ft-lbs (N-m)
				f' _c ≥ 2000 psi (13.8 MPa) Concrete			f' _c ≥ 4000 psi (27.6 MPa) Concrete			f' _c ≥ 2000 psi (13.8 MPa) Concrete			
				Ultimate lbs. (kN)	Std. Dev. lbs. (kN)	Allow. lbs. (kN)	Ultimate lbs. (kN)	Std. Dev. lbs. (kN)	Allow. lbs. (kN)	Ultimate lbs. (kN)	Std. Dev. lbs. (kN)	Allow. lbs. (kN)	
1/4 (6.4)	1 1/8 (29)	2 1/2 (64)	4 1/2 (114)	880 (3.9)	94 (0.4)	220 (1.0)	1,320 (5.9)	189 (0.8)	330 (1.5)	1,440 (6.4)	90 (0.4)	360 (1.6)	5 (7)
5/16 (7.9)	1 3/16 (37)	3 1/8 (79)	5 3/8 (146)	1,120 (5.0)	113 (0.5)	280 (1.2)	1,320 (5.9)	350 (1.6)	330 (1.5)	2,160 (9.6)	113 (0.5)	540 (2.4)	8 (11)
3/8 (9.5)	1 1/2 (38)	3 3/4 (95)	6 (152)	1,600 (7.1)	294 (1.3)	400 (1.8)	2,680 (11.9)	450 (2.0)	670 (3.0)	3,080 (13.7)	223 (1.0)	770 (3.4)	15 (20)
1/2 (12.7)	2 1/4 (57)	5 (127)	9 (229)	3,160 (14.1)	254 (1.1)	790 (3.5)	4,760 (21.2)	485 (2.2)	1,190 (5.3)	5,000 (22.2)	473 (2.1)	1,250 (5.6)	25 (34)
5/8 (15.9)	2 3/4 (70)	6 1/4 (159)	11 (279)	4,200 (18.7)	681 (3.0)	1,050 (4.7)	6,160 (27.4)	1,772 (7.9)	1,540 (6.9)	8,520 (37.9)	713 (3.2)	2,130 (9.5)	50 (68)
3/4 (19.1)	3 (86)	7 1/2 (191)	13 1/2 (343)	6,400 (28.5)	665 (3.0)	1,600 (7.1)	9,520 (42.3)	674 (3.0)	2,380 (10.6)	10,040 (44.7)	955 (4.2)	2,510 (11.2)	90 (122)

- The tabulated allowable loads are based on a safety factor of 4.0.
- Allowable loads may not be increased for short-term loading due to wind or seismic forces.
- Refer to allowable load-adjustment factors for spacing and edge distance on page 149.
- Drill bit diameter used in base material corresponds to nominal anchor diameter.
- Allowable tension loads may be linearly interpolated between concrete strengths listed.
- The minimum concrete thickness is 1 1/2 times the embedment depth.

*See page 13 for an explanation of the load table icons

Tension and Shear Loads for Sleeve-All® Anchors in Grout-Filled CMU



Size in. (mm)	Embed. Depth in. (mm)	Min. Edge Dist. in. (mm)	Min. End Dist. in. (mm)	Min. Spacing in. (mm)	Tension Load		Shear Load		Install. Torque ft-lbs (N-m)
					Ultimate lbs. (kN)	Allow. lbs. (kN)	Ultimate lbs. (kN)	Allow. lbs. (kN)	
Anchor Installed in a Single Face Shell									
3/8 (9.5)	1 1/2 (38)	12 (305)	12 (305)	24 (610)	1,746 (7.8)	350 (1.6)	2,871 (12.8)	575 (2.6)	15 (20)
1/2 (12.7)	2 1/4 (57)	12 (305)	12 (305)	24 (610)	3,384 (15.1)	675 (3.0)	5,670 (25.2)	1,135 (5.0)	25 (34)
5/8 (15.9)	2 3/4 (70)	12 (305)	12 (305)	24 (610)	3,970 (17.7)	795 (3.5)	8,171 (36.3)	1,635 (7.3)	50 (68)
3/4 (19.1)	3 (86)	12 (305)	12 (305)	24 (610)	6,395 (28.4)	1,280 (5.7)	12,386 (55.1)	2,475 (11.0)	90 (122)
Anchor Installed in Mortar "T" Joint									
3/8 (9.5)	1 1/2 (38)	8 (203)	8 (203)	24 (610)	1,927 (8.6)	385 (1.7)	3,436 (15.3)	685 (3.0)	15 (20)
1/2 (12.7)	2 1/4 (57)	8 (203)	8 (203)	24 (610)	3,849 (17.1)	770 (3.4)	5,856 (26.0)	1,170 (5.2)	25 (34)
5/8 (15.9)	2 3/4 (70)	8 (203)	8 (203)	24 (610)	4,625 (20.6)	925 (4.1)	7,040 (31.3)	1,410 (6.3)	50 (68)
3/4 (19.1)	3 (86)	8 (203)	8 (203)	24 (610)	5,483 (24.4)	1,095 (4.9)	7,869 (35.0)	1,575 (7.0)	90 (122)

*See page 13 for an explanation of the load table icons

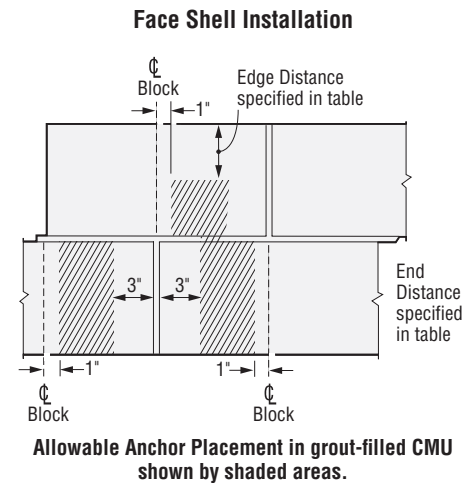

- The tabulated allowable loads are based on a safety factor of 5.0 for installations under the IBC and IRC.
- Listed loads may be applied to installations through a face shell with the following placement guidelines:
 - Minimum 3" from vertical mortar joint.
 - Minimum 1" from vertical cell centerline.
- Values for 6- and 8-inch wide concrete masonry units (CMU) with a minimum specified compressive strength of masonry, f'_m, at 28 days is 1500 psi.
- Embedment depth is measured from the outside face of the concrete masonry unit.
- Drill bit diameter used in base material corresponds to nominal anchor diameter.
- Allowable loads may not be increased for short-term loading due to wind or seismic forces.

Sleeve-All® Technical Information

**Load-Adjustment Factors for Sleeve-All® Anchors in Normal-Weight Concrete:
Edge Distance and Spacing, Tension and Shear Loads**

How to use these charts:

1. The following tables are for reduced edge distance and spacing.
2. Locate the anchor size to be used for either a tension and/or shear load application.
3. Locate the edge distance (C_{act}) or spacing (S_{act}) at which the anchor is to be installed.
4. The load adjustment factor (f_c or f_s) is the intersection of the row and column.
5. Multiply the allowable load by the applicable load adjustment factor.
6. Reduction factors for multiple edges or spacing are multiplied together.

Edge Distance Tension (f_c)



Edge Dist. C_{act} (in.)	Size C_{cr}	1/4	5/16	3/8	1/2	5/8	3/4
	C_{min}	1 1/4	1 1/8	1 1/8	2 1/2	3 1/8	3 3/4
	f_{emin}	0.60	0.60	0.60	0.60	0.60	0.60
1 1/4		0.60					
1 1/2		0.68					
1 9/16		0.70	0.60				
1 7/8		0.80	0.68	0.60			
2		0.84	0.71	0.63			
2 1/2		1.00	0.84	0.73	0.60		
3			0.97	0.84	0.68		
3 1/8			1.00	0.87	0.70	0.60	
3 1/2				0.95	0.76	0.65	
3 3/4				1.00	0.80	0.68	0.60
4					0.84	0.71	0.63
4 1/2					0.92	0.78	0.68
5					1.00	0.84	0.73
5 1/2						0.90	0.79
6						0.97	0.84
6 1/4						1.00	0.87
6 1/2							0.89
7							0.95
7 1/2							1.00

*See page 13 for an explanation of the load table icons

See Notes Below

Spacing Tension and Shear (f_s)



S_{act} (in.)	Size	1/4	5/16	3/8	1/2	5/8	3/4
	E	1 1/8	1 1/8	1 1/2	2 1/4	2 3/4	3 3/8
	S_{cr}	4 1/2	5 3/4	6	9	11	13 1/2
	S_{min}	2 1/4	2 7/8	3	4 1/2	5 1/2	6 3/4
	f_{smin}	0.50	0.50	0.50	0.50	0.50	0.50
2 1/4		0.50					
2 1/2		0.56					
2 7/8		0.64	0.50				
3		0.67	0.52	0.50			
3 1/2		0.78	0.61	0.58			
4		0.89	0.70	0.67			
4 1/2		1.00	0.78	0.75	0.50		
5			0.87	0.83	0.56		
5 1/2			0.96	0.92	0.61	0.50	
5 3/4			1.00	0.96	0.64	0.52	
6				1.00	0.67	0.55	
6 1/2					0.72	0.59	
6 3/4					0.75	0.61	0.50
7					0.78	0.64	0.52
8					0.89	0.73	0.59
9					1.00	0.82	0.67
10						0.91	0.74
11						1.00	0.81
12							0.89
13							0.96
13 1/2							1.00

1. E = Embedment depth (inches).
2. S_{act} = actual spacing distance at which anchors are installed (inches).
3. S_{cr} = critical spacing distance for 100% load (inches).
4. S_{min} = minimum spacing distance for reduced load (inches).
5. f_s = adjustment factor for allowable load at actual spacing distance.
6. f_{scr} = adjustment factor for allowable load at critical spacing distance. f_{scr} is always = 1.00.
7. f_{smin} = adjustment factor for allowable load at minimum spacing distance.
8. $f_s = f_{smin} + [(1 - f_{smin}) (S_{act} - S_{min}) / (S_{cr} - S_{min})]$.

Edge Distance Shear (f_c)



Edge Dist. C_{act} (in.)	Size C_{cr}	1/4	5/16	3/8	1/2	5/8	3/4
	C_{min}	1 1/4	1 1/8	1 1/8	2 1/2	3 1/8	3 3/4
	f_{emin}	0.30	0.30	0.30	0.30	0.30	0.30
1 1/4		0.30					
1 1/2		0.44					
1 9/16		0.48	0.30				
1 7/8		0.65	0.44	0.30			
2		0.72	0.50	0.35			
2 1/2		1.00	0.72	0.53	0.30		
3			0.94	0.72	0.44		
3 1/8			1.00	0.77	0.48	0.30	
3 1/2				0.91	0.58	0.38	
3 3/4				1.00	0.65	0.44	0.30
4					0.72	0.50	0.35
4 1/2					0.86	0.61	0.44
5					1.00	0.72	0.53
5 1/2						0.83	0.63
6						0.94	0.72
6 1/4						1.00	0.77
6 1/2							0.81
7							0.91
7 1/2							1.00

1. C_{act} = actual edge distance at which anchor is installed (inches).
2. C_{cr} = critical edge distance for 100% load (inches).
3. C_{min} = minimum edge distance for reduced load (inches).
4. f_c = adjustment factor for allowable load at actual edge distance.
5. f_{ccr} = adjustment factor for allowable load at critical edge distance. f_{ccr} is always = 1.00.
6. f_{cmin} = adjustment factor for allowable load at minimum edge distance.
7. $f_c = f_{cmin} + [(1 - f_{cmin}) (C_{act} - C_{min}) / (C_{cr} - C_{min})]$.

Drop-In Internally Threaded Expansion Shell Anchor

Drop-in anchors are internally threaded, deformation-controlled expansion anchors with a preassembled expander plug, suitable for flush mount applications in solid base materials. The anchor is set by driving the expansion plug towards the bottom of the anchor using the setting tool. Drop-in anchors are also available in coil-threaded versions for ½" and ¾" coil threaded rod.

The Lipped Drop-In (DIAL) features a lip at the top of the anchor body that keeps the top of the anchor flush with the concrete. This eliminates the need for precisely drilled hole depths and allows for easier flush installation, consistent embedment and uniform rod lengths.

Short Drop-In anchors are for use in solid and hollow concrete. The short length permits shallow embedment that helps to avoid drilling into rebar or prestressing strands. The wide surface flange enables the Short Drop-In to be installed in deep or bottomless holes. Fixed-depth drill bits are also available to take the guesswork out of drilling to the correct depth for these ¾" and ½" Short Drop-Ins. Using the fixed-depth bit drill bit prevents overdrilling, which saves time and prolongs bit life.

MATERIAL: Carbon and stainless steel
(DIA37S and DIA50S available in zinc-plated, carbon steel only)

FINISH: Carbon steel: Zinc plated

INSTALLATION:

- Drill a hole in the base material using the appropriate diameter carbide drill bit as specified in the table. Drill the hole to the specified embedment depth plus ¼" for flush mounting. Blow the hole clean using compressed air. Overhead installations need not be blown clean.

Caution: Oversized holes will make it difficult to set the anchor and will reduce the anchor's load capacity.

- Insert designated anchor into hole. Tap with hammer until flush against surface.
- Using the designated Drop-In setting tool, drive expander plug towards the bottom of the anchor until shoulder of setting tool makes contact with the top of the anchor.
- Minimum thread engagement should be equal to the nominal diameter of the threaded insert.

CODES: Drop-In: City of L.A. RR24682; Factory Mutual 3017082; Underwriters Laboratories File Ex3605. Meets requirements of Federal Specifications A-A-55614, Type I. Short Drop-In: Factory Mutual 3017082 and Underwriters Laboratories File Ex3605.

The load tables list values based upon results from the most recent testing and may not reflect those in current code reports. Where code jurisdictions apply, consult the current reports for applicable load values.

TEST CRITERIA: The Drop-In anchor has been tested in accordance with ICC-ES's Acceptance Criteria for Expansion Anchors (AC01) for the following:

- Seismic/wind loading
- Combination tension and shear loads
- Critical and minimum edge distance and spacing

SUGGESTED SPECIFICATIONS: Drop-In anchors shall be internally threaded, expanding shell anchors. The anchor shell shall be zinc plated carbon steel with a minimum 70,000 psi tensile strength, type 303 or 316 stainless steel, as called for on the drawings. Drop-In anchors shall meet Federal Specification A-A-55614, Type I. Anchors shall be Drop-In anchors from Simpson Strong-Tie, Pleasanton, CA. Anchors shall be installed following the Simpson Strong-Tie instructions for Drop-In internally threaded expansion shell anchors.

Material Specifications

Anchor Component	Component Material		
	Zinc Plated Carbon Steel	Type 303 Stainless Steel	Type 316 Stainless Steel
Anchor Body	Meets minimum 70,000 psi tensile	AISI 303. Meets chemical requirements of ASTM A-582	Type 316
Expander Plug	Meets minimum 50,000 psi tensile	AISI 303	Type 316
Thread	UNC/Coil-thread	UNC	UNC

Note: DIA37S, DIA50C and DIA75C are not available in stainless steel.



Drop-In



Lipped Drop-In



Short Drop-In



Coil-Thread Drop-In

Installation Sequence

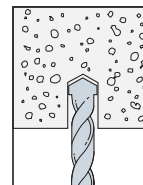

1. Drill a hole using the specified diameter carbide bit into the base material to a depth of at least ¼" deeper than the required embedment. Then blow the hole clean of dust and debris using compressed air.

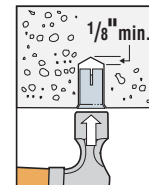

2. Insert Drop-In anchor into hole. Tap with hammer until flush against surface.

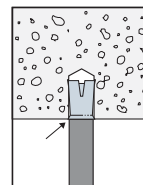

3. Using the Drop-In anchor setting tool, drive expander plug toward the bottom of the anchor until the shoulder of setting tool makes contact with the top of the anchor.

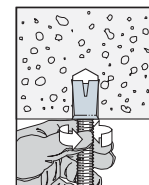

4. Install threaded rod into the anchor to support pipes, wiring, etc.

Drop-In Internally Threaded Expansion Shell Anchor

Drop-In Anchor Product Data - Carbon and Stainless Steel

Rod Size (in.)	Carbon Steel Model No.	303 Stainless Model No.	316 Stainless Model No.	Drill Bit Diameter (in.)	Bolt Threads (per in.)	Body Length (in.)	Thread Length (in.)	Quantity	
								Box	Ctn.
1/4	DIA25	DIA25SS	DIA256SS	3/8	20	1	3/8	100	500
3/8	DIA37	DIA37SS	DIA376SS	1/2	16	1 1/2	5/8	50	250
1/2	DIA50	DIA50SS	DIA506SS	5/8	13	2	3/4	50	200
5/8	DIA62	DIA62SS	—	7/8	11	2 1/2	1	25	100
3/4	DIA75	DIA75SS	—	1	10	3 1/8	1 1/4	20	80



Drop-In Anchor

Lipped Drop-In Anchor Product Data

Rod Size (in.)	Carbon Steel Model No.	Drill Bit Diameter (in.)	Bolt Threads (per in.)	Body Length (in.)	Thread Length (in.)	Quantity	
						Box	Ctn.
1/4	DIAL25	3/8	20	1	3/8	100	500
3/8	DIAL37	1/2	16	1 1/2	5/8	50	250
1/2	DIAL50	5/8	13	2	3/4	50	200



Lipped Drop-In Anchor

Short Drop-In Anchor Product Data

Rod Size (in.)	Model No.	Drill Bit Diameter (in.)	Bolt Threads (per in.)	Body Length (in.)	Thread Length (in.)	Quantity	
						Box	Carton
3/8	DIA37S ¹	1/2	16	3/4	1/4	100	500
1/2	DIA50S ¹	5/8	13	1	5/16	50	200

1. A dedicated setting tool is included with each box of DIA37S and DIA50S.



Short Drop-In Anchor

Coil-Thread Drop-In Anchor Product Data

Rod Size (in.)	Carbon Steel Model No.	Drill Bit Diameter (in.)	Bolt Threads (per in.)	Body Length (in.)	Thread Length (in.)	Quantity	
						Box	Ctn.
1/2	DIA50C ¹	5/8	6	2	3/4	50	200
3/4	DIA75C ¹	1	5	3 1/8	1 1/4	20	80

1. DIA50C and DIA75C accept 1/2" and 3/4" coil-thread rod, respectively.



Coil-Thread Drop-In Anchor

Drop-In Anchor Setting Tool Product Data

Model No.	For use With	Box Qty.
DIAS25	DIA25, DIAL25	10
DIAS37	DIA37, DIAL37	10
DIAS50	DIA50, DIA50C, DIAL50	10
DIAS62	DIA62	5
DIAS75	DIA75, DIA75C	5

1. Setting Tools sold separately except for DIA37S and DIA50S.
2. Setting Tools for use with carbon and stainless-steel Drop-In anchors.



Drop-In Anchor Setting Tool

Fixed-Depth Drill Bit Product Data

Drill Bit Diameter (in.)	Drop-In Anchor (in.)	Model No.	Drill Depth (in.)
1/2	3/8	MDPL050DIAS	15/16
5/8	1/2	MDPL062DIAS	1 1/4



Fixed-Depth Drill Bit

Drop-In Internally Threaded Expansion Shell Anchor

Tension Loads for Drop-In (Carbon and Stainless Steel), Lipped Drop-In (Carbon Steel) and Coil-Thread Drop-In (Carbon Steel) Anchors in Normal-Weight Concrete



Rod Size in. (mm)	Drill Bit Dia. (in.)	Embed. Depth in. (mm)	Critical Edge Dist. in. (mm)	Critical Spacing in. (mm)	Tension Load						
					$f'_c \geq 2000$ psi (13.8 MPa) Concrete			$f'_c \geq 3000$ psi (20.7 MPa) Concrete		$f'_c \geq 4000$ psi (27.6 MPa) Concrete	
					Ultimate lbs. (kN)	Std. Dev. lbs. (kN)	Allowable lbs. (kN)	Allowable lbs. (kN)	Ultimate lbs. (kN)	Std. Dev. lbs. (kN)	Allowable lbs. (kN)
¼ (6.4)	⅜	1 (25)	3 (76)	4 (102)	1,400 (6.2)	201 (0.9)	350 (1.6)	405 (1.8)	1,840 (8.2)	451 (2.0)	460 (2.0)
⅜ (9.5)	½	1½ (38)	4½ (114)	6 (152)	2,400 (10.7)	251 (1.1)	600 (2.7)	795 (3.5)	3,960 (17.6)	367 (1.6)	990 (4.4)
½ (12.7)	⅝	2 (51)	6 (152)	8 (203)	3,320 (14.8)	372 (1.7)	830 (3.7)	1,178 (5.2)	6,100 (27.1)	422 (1.9)	1,525 (6.8)
⅝ (15.9)	¾	2½ (64)	7½ (191)	10 (254)	5,040 (22.4)	689 (3.1)	1,260 (5.6)	1,715 (7.6)	8,680 (38.6)	971 (4.3)	2,170 (9.7)
¾ (19.1)	1	3⅝ (79)	9 (229)	12½ (318)	8,160 (36.3)	961 (4.3)	2,040 (9.1)	2,365 (10.5)	10,760 (47.9)	1,696 (7.5)	2,690 (12.0)

1. The allowable loads listed are based on a safety factor of 4.0.
2. Refer to allowable load-adjustment factors for edge distance and spacing on page 155.
3. Allowable loads may be linearly interpolated between concrete strengths listed.
4. The minimum concrete thickness is 1½ times the embedment depth.

* See page 13 for an explanation of the load table icons

Shear Loads for Drop-In (Carbon and Stainless Steel), Lipped Drop-In (Carbon Steel) and Coil-Thread Drop-In (Carbon Steel) Anchors in Normal-Weight Concrete



Rod Size in. (mm)	Drill Bit Dia. in.	Embed. Depth in. (mm)	Critical Edge Dist. in. (mm)	Critical Spacing in. (mm)	Shear Load					
					$f'_c \geq 2000$ psi (13.8 MPa) Concrete			$f'_c \geq 3000$ psi (20.7 MPa) Concrete		$f'_c \geq 4000$ psi (27.6 MPa) Concrete
					Ultimate lbs. (kN)	Std. Dev. lbs. (kN)	Allowable lbs. (kN)	Allowable lbs. (kN)	Allowable lbs. (kN)	
¼ (6.4)	⅜	1 (25)	3½ (89)	4 (102)	1,960 (8.7)	178 (0.8)	490 (2.2)	490 (2.2)	490 (2.2)	
⅜ (9.5)	½	1½ (38)	5¼ (133)	6 (152)	3,240 (14.4)	351 (1.6)	810 (3.6)	925 (4.1)	1,040 (4.6)	
½ (12.7)	⅝	2 (51)	7 (178)	8 (203)	7,000 (31.1)	562 (2.5)	1,750 (7.8)	1,750 (7.8)	1,750 (7.8)	
⅝ (15.9)	¾	2½ (64)	8¾ (222)	10 (254)	11,080 (49.3)	923 (4.1)	2,770 (12.3)	2,770 (12.3)	2,770 (12.3)	
¾ (19.1)	1	3⅝ (79)	10½ (267)	12½ (318)	13,800 (61.4)	1,781 (7.9)	3,450 (15.3)	3,725 (16.6)	4,000 (17.8)	

1. The allowable loads listed are based on a safety factor of 4.0.
2. Refer to allowable load-adjustment factors for edge distance and spacing on page 155.
3. Allowable loads may be linearly interpolated between concrete strengths listed.
4. The minimum concrete thickness is 1½ times the embedment depth.

Drop-In Internally Threaded Expansion Shell Anchor

Tension and Shear Loads for Drop-In (Carbon Steel) and Lipped Drop-In (Carbon Steel) Anchors in Sand-Lightweight Concrete over Metal Deck



Model No.	Rod Size in. (mm)	Drill Bit Dia. in.	Embed. Depth in. (mm)	Tension Critical Edge Dist. in. (mm)	Shear Critical Edge Dist. in. (mm)	Critical Spacing in. (mm)	Tension Load (Install through Metal Deck)			Shear Load (Install through Metal Deck)		
							$f'_c \geq 3000$ psi (20.7 MPa) Concrete			$f'_c \geq 3000$ psi (20.7 MPa) Concrete		
							Ultimate lbs. (kN)	Std. Dev. lbs. (kN)	Allowable lbs. (kN)	Ultimate lbs. (kN)	Std. Dev. lbs. (kN)	Allowable lbs. (kN)
DIA37	3/8 (9.5)	1/2	1 1/2 (38)	6 (152)	7 (178)	8 (203)	3,000 (13.3)	367 (1.6)	750 (3.3)	2,400 (10.7)	187 (0.8)	600 (2.7)
DIA50	1/2 (12.7)	5/8	2 (51)	8 (203)	9 3/8 (238)	10 5/8 (270)	3,580 (15.9)	861 (3.8)	895 (4.0)	5,600 (24.9)	200 (0.9)	1,400 (6.2)

1. The allowable loads listed are based on a safety factor of 4.0.
2. Allowable loads may not be increased for short-term loading due to wind or seismic forces.
3. Refer to allowable load-adjustment factors for edge distance and spacing on page 156.

*See page 13 for an explanation of the load table icons

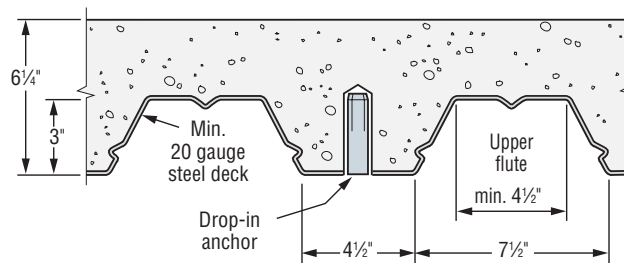

Lightweight Concrete over Metal Deck

Tension and Shear Loads for 3/8" and 1/2" Short Drop-In Anchor in Sand-Lightweight Concrete Fill over Metal Deck



Model No.	Rod Size (in.)	Drill Bit Dia. (in.)	Emb. Depth (in.)	Tension Critical End Distance (in.)	Shear Critical End Distance (in.)	Critical Spacing (in.)	Install through the Lower Flute or Upper Flute of Metal Deck, $f'_c \geq 3000$ psi Concrete			
							Tension Load		Shear Load	
							Ultimate (lbs.)	Allowable (lbs.)	Ultimate (lbs.)	Allowable (lbs.)
DIA37S	3/8	1/2	3/4	6	7	8	1344	335	1649	410
DIA50S	1/2	5/8	1	8	9 3/8	10 5/8	1711	430	2070	515

1. The allowable loads listed are based on a safety factor of 4.0.
2. Allowable loads may not be increased for short-term loading due to wind or seismic forces.
3. Refer to allowable load-adjustment factors for edge distances and spacing on page 156.
4. Anchors were installed with a 1" offset from the centerline of the flute.

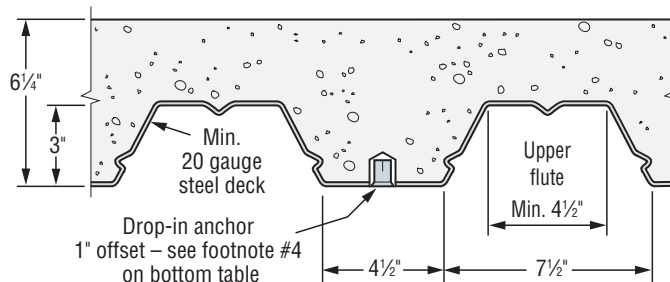

Lightweight Concrete over Metal Deck

Drop-In Internally Threaded Expansion Shell Anchor



Tension and Shear Loads for 3/8" and 1/2" Short Drop-In Anchor in Normal-Weight Concrete

Model No.	Rod Size (in.)	Drill Bit Dia. (in.)	Emb. Depth (in.)	Tension Critical Edge Distance (in.)	Shear Critical Edge Distance (in.)	Critical Spacing (in.)	Normal-Weight Concrete, $f'_c \geq 2500$ psi				Normal-Weight Concrete, $f'_c \geq 4000$ psi			
							Tension Load		Shear Load		Tension Load		Shear Load	
							Ultimate (lbs.)	Allowable (lbs.)	Ultimate (lbs.)	Allowable (lbs.)	Ultimate (lbs.)	Allowable (lbs.)	Ultimate (lbs.)	Allowable (lbs.)
DIA37S	3/8	1/2	3/4	4 1/2	5 1/4	3	1,500	375	2,274	570	2,170	540	3,482	870
DIA50S	1/2	5/8	1	6	7	4	2,039	510	3,224	805	3,420	855	5,173	1,295

1. The allowable loads listed are based on a safety factor of 4.0.
2. Allowable loads may not be increased for short-term loading due to wind or seismic forces.
3. Refer to allowable load-adjustment factors for edge distances and spacing on page 155.
4. Allowable loads may be linearly interpolated between concrete strengths.
5. The minimum concrete thickness is 1 1/2 times the embedment depth.



Tension and Shear Loads for 3/8" and 1/2" Short Drop-In Anchor in Hollow Core Concrete Panel

Model No.	Rod Size (in.)	Drill Bit Dia. (in.)	Emb. Depth (in.)	Tension Critical Edge Distance (in.)	Shear Critical Edge Distance (in.)	Critical Spacing (in.)	Hollow Core Concrete Panel, $f'_c \geq 4000$ psi			
							Tension Load		Shear Load	
							Ultimate (lbs.)	Allowable (lbs.)	Ultimate (lbs.)	Allowable (lbs.)
DIA37S	3/8	1/2	3/4	4 1/2	5 1/4	3	1,860	465	3,308	825
DIA50S	1/2	5/8	1	6	7	4	2,650	660	4,950	1,235

1. The allowable loads listed are based on a safety factor of 4.0.
2. Allowable loads may not be increased for short-term loading due to wind or seismic forces.
3. Refer to allowable load-adjustment factors for edge distances and spacing on page 155.
4. Allowable loads may be linearly interpolated between concrete strengths.

*See page 13 for an explanation of the load table icons

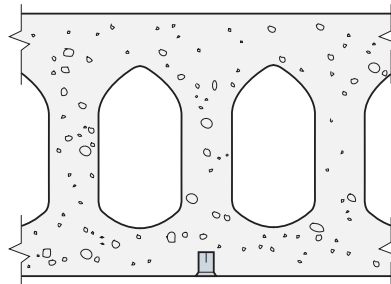

Hollow Core Concrete Panel
(Anchor can be installed below web or hollow core)

Drop-In Technical Information

Load-Adjustment Factors for Drop-In (Carbon and Stainless Steel) and Lipped Drop-In (Carbon Steel) Anchors in Normal-Weight Concrete: Edge Distance and Spacing, Tension and Shear Loads

How to use these charts:

1. The following tables are for reduced edge distance and spacing.
2. Locate the anchor size to be used for either a tension and/or shear load application.
3. Locate the edge distance (C_{act}) or spacing (S_{act}) at which the anchor is to be installed.
4. The load adjustment factor (f_c or f_s) is the intersection of the row and column.
5. Multiply the allowable load by the applicable load adjustment factor.
6. Reduction factors for multiple edges or spacing are multiplied together.

Edge Distance Tension (f_c)



Edge Dist. (C_{act}) (in.)	Size	1/4	3/8	1/2	5/8	3/4
	C_{cr}	3	4 1/2	6	7 1/2	9
C_{min}	1 3/4	2 5/8	3 1/2	4 5/8	5 1/4	
f_{cmin}	0.65	0.65	0.65	0.65	0.65	0.65
1 3/4		0.65				
2		0.72				
2 1/2		0.86				
2 5/8		0.90	0.65			
3		1.00	0.72			
3 1/2			0.81	0.65		
4			0.91	0.72		
4 5/8			0.98	0.77	0.65	
4 1/2			1.00	0.79	0.66	
5				0.86	0.72	
5 1/4				0.90	0.75	0.65
5 1/2				0.93	0.78	0.67
6				1.00	0.83	0.72
6 1/2					0.89	0.77
7					0.94	0.81
7 1/2					1.00	0.86
8						0.91
8 1/2						0.95
9						1.00

*See page 13 for an explanation of the load table icons

Spacing Tension and Shear (f_s)

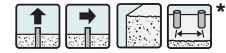

S_{act} (in.)	Size	1/4	3/8 ⁹	3/8	1/2	5/8	3/4
	E	1	3/4	1 1/2	2	2 1/2	3 1/8
S_{cr}	4	3	6	8	10	12 1/2	
S_{min}	2	1 1/2	3	4	5	6 1/4	
f_{smin}	0.50	0.50	0.50	0.50	0.50	0.50	0.50
1 1/2			0.50				
2		0.50	0.67				
2 1/2		0.63	0.83				
3		0.75	1.00	0.50			
3 1/2		0.88		0.58			
4		1.00		0.67	0.50		
4 1/2				0.75	0.56		
5				0.83	0.63	0.50	
5 1/2				0.92	0.69	0.55	
6				1.00	0.75	0.60	
6 1/4					0.78	0.63	0.50
7					0.88	0.70	0.56
8					1.00	0.80	0.64
9						0.90	0.72
10						1.00	0.80
11							0.88
12							0.96
12 1/2							1.00

1. E = Embedment depth (inches).
2. S_{act} = actual spacing distance at which anchors are installed (inches).
3. S_{cr} = critical spacing distance for 100% load (inches).
4. S_{min} = minimum spacing distance for reduced load (inches).
5. f_s = adjustment factor for allowable load at actual spacing distance.
6. f_{scr} = adjustment factor for allowable load at critical spacing distance. f_{scr} is always = 1.00.
7. f_{smin} = adjustment factor for allowable load at minimum spacing distance.
8. $f_s = f_{smin} + [(1 - f_{smin})(S_{act} - S_{min}) / (S_{cr} - S_{min})]$.
9. ⁹ Short Drop-In (DIA37S).

Edge Distance Shear (f_c)



Edge Dist. (C_{act}) (in.)	Size	1/4	3/8	1/2	5/8	3/4
	C_{cr}	3 1/2	5 1/4	7	8 3/4	10 1/2
C_{min}	1 3/4	2 5/8	3 1/2	4 5/8	5 1/4	
f_{cmin}	0.45	0.45	0.45	0.45	0.45	0.45
1 3/4		0.45				
2		0.53				
2 1/2		0.69				
2 5/8		0.73	0.45			
3		0.84	0.53			
3 1/2		1.00	0.63	0.45		
4			0.74	0.53		
4 5/8			0.82	0.59	0.45	
4 1/2			0.84	0.61	0.47	
5			0.95	0.69	0.53	
5 1/4			1.00	0.73	0.56	0.45
5 1/2				0.76	0.59	0.48
6				0.84	0.65	0.53
6 1/2				0.92	0.72	0.58
7				1.00	0.78	0.63
7 1/2					0.84	0.69
8					0.91	0.74
8 1/2					0.97	0.79
8 3/4					1.00	0.82
9						0.84
9 1/2						0.90
10						0.95
10 1/2						1.00

1. C_{act} = actual edge distance at which anchor is installed (inches).
2. C_{cr} = critical edge distance for 100% load (inches).
3. C_{min} = minimum edge distance for reduced load (inches).
4. f_c = adjustment factor for allowable load at actual edge distance.
5. f_{ccr} = adjustment factor for allowable load at critical edge distance. f_{ccr} is always = 1.00.
6. f_{cmin} = adjustment factor for allowable load at minimum edge distance.
7. $f_c = f_{cmin} + [(1 - f_{cmin})(C_{act} - C_{min}) / (C_{cr} - C_{min})]$.

Drop-In Technical Information

Load-Adjustment Factors for Drop-In (Carbon and Stainless Steel) and Lipped Drop-In (Carbon Steel) Anchors in Sand-Lightweight Concrete over Metal Deck: Edge Distance and Spacing, Tension and Shear Loads

How to use these charts:

1. The following tables are for reduced edge distance and spacing.
2. Locate the anchor size to be used for either a tension and/or shear load application.
3. Locate the edge distance (C_{act}) or spacing (S_{act}) at which the anchor is to be installed.
4. The load adjustment factor (f_c or f_s) is the intersection of the row and column.
5. Multiply the allowable load by the applicable load adjustment factor.
6. Reduction factors for multiple edges or spacing are multiplied together.

Edge Distance Tension (f_c)

Edge Dist. (C_{act} in.)	Size	¾	1½
	C_{cr}	6	8
	C_{min}	3½	4¾
	f_{cmin}	0.65	0.65
3½		0.65	
4		0.72	
4½		0.79	
4¾		0.83	0.65
5		0.86	0.68
5½		0.93	0.73
6		1.00	0.78
6½			0.84
7			0.89
7½			0.95
8			1.00



* See page 13 for an explanation of the load table icons

Spacing Tension and Shear (f_s)

S_{act} (in.)	Size	¾	1½
	S_{cr}	8	10¾
	S_{min}	4	5¼
	f_{smin}	0.50	0.50
4		0.50	
4½		0.56	
5		0.63	
5¼		0.66	0.50
6		0.75	0.57
6½		0.81	0.62
7		0.88	0.66
7½		0.94	0.71
8		1.00	0.76
8½			0.80
9			0.85
9½			0.90
10			0.94
10¾			1.00



See Notes Below

Edge Distance Shear (f_c)

Edge Dist. (C_{act} in.)	Size	¾	1½
	C_{cr}	7	9¾
	C_{min}	3½	4¾
	f_{cmin}	0.45	0.45
3½		0.45	
4		0.53	
4½		0.61	
4¾		0.65	0.45
5		0.69	0.48
5½		0.76	0.54
6		0.84	0.60
6½		0.92	0.66
7		1.00	0.72
7½			0.78
8			0.84
8½			0.90
9			0.96
9¾			1.00



1. S_{act} = actual spacing distance at which anchors are installed (inches).
2. S_{cr} = critical spacing distance for 100% load (inches).
3. S_{min} = minimum spacing distance for reduced load (inches).
4. f_s = adjustment factor for allowable load at actual spacing distance.
5. f_{scr} = adjustment factor for allowable load at critical spacing distance. f_{scr} is always = 1.00.
6. f_{smin} = adjustment factor for allowable load at minimum spacing distance.
7. $f_s = f_{smin} + [(1 - f_{smin}) (S_{act} - S_{min}) / (S_{cr} - S_{min})]$.

1. C_{act} = actual edge distance at which anchor is installed (inches).
2. C_{cr} = critical edge distance for 100% load (inches).
3. C_{min} = minimum edge distance for reduced load (inches).
4. f_c = adjustment factor for allowable load at actual edge distance.
5. f_{ocr} = adjustment factor for allowable load at critical edge distance. f_{ocr} is always = 1.00.
6. f_{cmin} = adjustment factor for allowable load at minimum edge distance.
7. $f_c = f_{cmin} + [(1 - f_{cmin}) (C_{act} - C_{min}) / (C_{cr} - C_{min})]$.

Blue Banger Hanger® Cast-In-Place, Internally Threaded Inserts

Blue Banger Hanger® internally threaded inserts are cast into the underside of the concrete deck after being fastened to the top of wood forms or metal deck. Once the concrete has cured, the anchor provides an attachment point for threaded rod used to hang electrical, mechanical and plumbing utilities. The Blue Banger Hanger insert is the only pre-pour insert to offer the patented multi-thread design that enables one size insert to handle multiple diameters of threaded rod.

FEATURES:

- Quick and easy installation saves time and money- no assembly required
- Patented multi-thread design allows each hanger to accept multiple diameters of threaded rod. Three sizes of hangers can handle all applications, reducing contractor and distributor inventories
- Multi-thread design allows threaded rod size to be changed after the anchor is in the concrete
- Machined steel insert with large flanged head provides high tension and shear loads for overhead attachments
- Positive attachment to form keeps the hanger vertical and in the correct position.
- Internal threads eliminate the cost of rod couplers
- The head is stamped with the Simpson Strong-Tie® "≠" sign for easy identification before the concrete pour



Patented multi-thread design allows one product to handle up to three rod diameters.



Blue Banger Hanger®
Metal Deck Insert (BBMD)
U.S. Patent 6,240,697B1



Blue Banger Hanger®
Roof Deck Insert (BBRD)
U.S. Patent 6,240,697B1

MATERIAL: Carbon steel

FINISH: Yellow-zinc dichromate

CODES: Factory Mutual 3024378 (except roof deck insert); Underwriters Laboratories File EX3605 (except roof deck insert); Metal deck insert (BBMD) in compliance with UL Standard 2043, 2nd edition, "Fire test for heat and visible smoke release for discrete products and their accessories installed in air-handling spaces."

Blue Banger Hanger Product Data

Hanger Type	For Rod Diameter (in.)	Deck Hole Diameter (in.)	Model No.	Carton Qty.
Metal Deck Insert	1/4, 3/8, 1/2	3/16-7/8	BBMD2550	100
	3/8, 1/2, 5/8	1 1/8-1 3/16	BBMD3762	50
	5/8, 3/4	1 3/16-1 1/4	BBMD6275	50
Roof Deck Insert	1/4, 3/8, 1/2	7/8	BBRD2550	50
Wood Form Insert	1/4, 3/8, 1/2	N/A	BBWF2550	200
	3/8, 1/2, 5/8		BBWF3762	150
	5/8, 3/4		BBWF6275	150



Blue Banger Hanger®
Wood Form Insert (BBWF)
U.S. Patent 6,240,697B1



Multiple rod diameters are easily accommodated with the Blue Banger Hanger®.

Blue Banger Hanger® Cast-In-Place, Internally Threaded Inserts

BLUE BANGER HANGER® – METAL DECK-INSERT

FEATURES:

- 3" plastic sleeve keeps internal threads clean.
- Extended length of the sleeve allows easy location of the insert even with fireproofing on the underside of the deck. Also provides guidance to align threaded rod with the internal threads.
- Installed height of 2" allows the insert to be used on top of, or between, deck ribs.
- Compression spring keeps the insert perpendicular to the deck, even if it is bumped or stepped on after installation.
- Multi-thread design: Each insert accepts 2–3 rod diameters.

INSTALLATION:

- Drill a hole in the metal deck using the appropriate diameter bit as referenced in the table.
- Insert the hanger into the hole and strike the top so that the plastic sleeve is forced through the hole and expands against the bottom side of the deck. The anchor can also be installed by stepping on it.



Metal-Deck Insert Installation Sequence

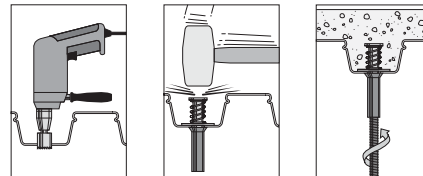

BLUE BANGER HANGER® – METAL-ROOF DECK INSERT

FEATURES:

- Low profile design doesn't interfere with roofing material
- Plastic sleeve allows for easy identification and keeps internal threads clean.
- Positive attachment to the roof deck prevents spinning and keeps the hanger in position.
- Pre-staked screws allow quick installation.
- Multi-thread design: The insert accepts 3 rod diameters.

INSTALLATION:

- Drill a hole in the metal deck using the appropriate diameter bit as referenced in the table.
- Insert the hanger into the hole and fasten to the deck with the two pre-staked, self-drilling sheet metal screws provided.

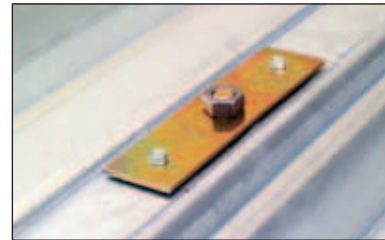

Metal-Roof Deck Insert Installation Sequence

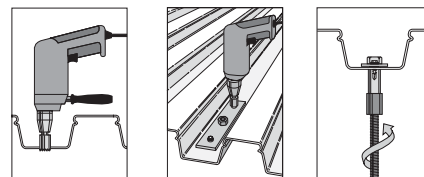

BLUE BANGER HANGER® – WOOD-FORM INSERT

FEATURES:

- Blue plastic ring acts as an insert locator when forms are removed.
- Plastic ring creates a countersunk recess to keep internal threads clean from concrete residue.
- Nails snap off with the swipe of a hammer after the forms are removed.
- Multi-thread design: Each insert accepts 2–3 rod diameters.

INSTALLATION:

- Strike the top of the hanger and drive the 3 mounting nails into the forming material until the bottom of the hanger is flush with the plywood. The hanger should be sitting 90° perpendicular to the forming material.
- Once concrete is hardened, and forms are stripped, strike the mounting nails to break them off.



Wood-Form Insert Installation Sequence

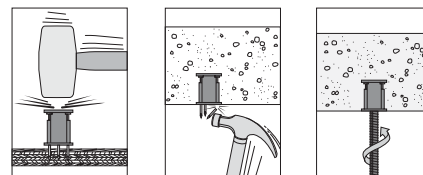

Blue Banger Hanger® Cast-In-Place, Internally Threaded Inserts

Wood-Form Insert: Tension Loads in Normal-Weight Concrete

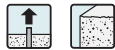

Model No.	Threaded Rod Dia. in.	Embed. Depth in. (mm)	Min. Edge Dist. in. (mm)	Min. Spacing in. (mm)	Tension Load Based on Concrete Strength		Tension Load Based on Rod Strength
					$f'_c \geq 3000$ psi (20.7 MPa) Concrete		A307 (SAE 1018)
					Ultimate lbs. (kN)	Allowable lbs. (kN)	Allowable lbs. (kN)
BBWF2550	1/4	2 (51)	7 (178)	8 (203)	6,820 (30.3)	1,705 (7.6)	940 (4.2)
	3/8						2,105 (9.4)
	1/2						3,750 (16.7)
BBWF3762	3/8	2 (51)	7 (178)	8 (203)	7,360 (32.7)	1,840 (8.2)	2,105 (9.4)
	1/2						3,750 (16.7)
	5/8						5,875 (26.1)
BBWF6275	5/8	2 (51)	7 (178)	8 (203)	7,420 (33.0)	1,855 (8.3)	5,875 (26.1)
	3/4						8,460 (37.6)

Roof-Deck Insert: Tension Loads in Metal Deck



Model No.	Drill Bit Dia. in.	Threaded Rod Dia. in.	Allowable Tension Load lbs. (kN)	
			1 1/2" Deck	3" Deck
BBRD2550	1 3/16-7/8	1/4	150 (0.7)	300 (1.3)
		3/8		
		1/2		

1. The allowable loads are based on a factor of safety of 4.0.
2. Allowable loads may not be increased for short-term loading due to wind or seismic forces.
3. Acceptability of deck deflection due to imposed loads must be investigated separately.
4. Threaded-rod strength must be investigated separately.
5. Anchors may be installed in the top or bottom flute of the metal deck.
6. Deck shall be 20-gauge minimum.

See Notes Below

Wood-Form Insert: Shear Loads in Normal-Weight Concrete



Model No.	Threaded Rod Dia. in.	Embed. Depth in. (mm)	Min. Edge Dist. in. (mm)	Min. Spacing in. (mm)	Shear Load Based on Concrete Strength		Shear Load Based on Rod Strength
					$f'_c \geq 3000$ psi (20.7 MPa) Concrete		A307 (SAE 1018)
					Ultimate lbs. (kN)	Allowable lbs. (kN)	Allowable lbs. (kN)
BBWF2550	1/2	2 (51)	7 (178)	8 (203)	8,750 (38.9)	2,185 (9.7)	1,930 (8.6)
BBWF3762	5/8	2 (51)	7 (178)	8 (203)	10,700 (47.6)	2,675 (11.9)	3,025 (13.4)
BBWF6275	3/4	2 (51)	7 (178)	8 (203)	10,460 (46.5)	2,615 (11.6)	4,360 (19.4)

Typical Roof-Deck Insert Installation in Metal Deck

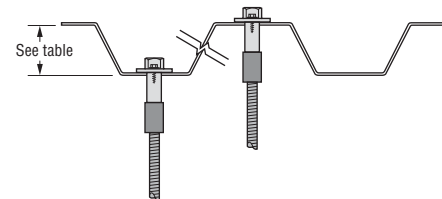

See Notes Below

Wood-Form Insert: Tension Loads in Sand-Lightweight Concrete



Model No.	Threaded Rod Dia. in.	Embed. Depth in. (mm)	Min. Edge Dist. in. (mm)	Min. Spacing in. (mm)	Tension Load Based on Concrete Strength		Tension Load Based on Rod Strength
					$f'_c \geq 3000$ psi (20.7 MPa) Concrete		A307 (SAE 1018)
					Ultimate lbs. (kN)	Allowable lbs. (kN)	Allowable lbs. (kN)
BBWF2550	1/4	2 (51)	7 (178)	8 (203)	4,280 (19.0)	1,070 (4.8)	940 (4.2)
	3/8						2,105 (9.4)
	1/2						3,750 (16.7)
BBWF6275	5/8	2 (51)	7 (178)	8 (203)	4,400 (19.6)	1,100 (4.9)	5,875 (26.1)
	3/4						8,460 (37.6)

*See page 13 for an explanation of the load table icons

See notes below.

Wood-Form Insert: Shear Loads in Sand-Lightweight Concrete



Model No.	Threaded Rod Dia. in.	Embed. Depth in. (mm)	Min. Edge Dist. in. (mm)	Min. Spacing in. (mm)	Shear Load Based on Concrete Strength		Shear Load Based on Rod Strength
					$f'_c \geq 3000$ psi (20.7 MPa) Concrete		A307 (SAE 1018)
					Ultimate lbs. (kN)	Allowable lbs. (kN)	Allowable lbs. (kN)
BBWF2550	1/2	2 (51)	7 (178)	8 (203)	8,600 (38.2)	2,150 (9.6)	1,930 (8.6)
BBWF6275	3/4	2 (51)	7 (178)	8 (203)	9,260 (41.2)	2,315 (10.3)	4,360 (19.4)

1. Allowable load must be the lesser of the concrete or steel strength.
2. The allowable loads based on concrete strength are based on a factor of safety of 4.0.
3. Allowable loads may not be increased for short-term loading due to wind or seismic forces.
4. Mechanical and plumbing design codes may prescribe lower allowable loads. Verify with local codes.
5. Minimum concrete slab thickness = 2x embedment depth.

Blue Banger Hanger® Cast-In-Place, Internally Threaded Inserts



* See page 13 for an explanation of the load table icons

Metal Deck Insert: Tension Loads in Normal-Weight or Sand-Lightweight Concrete over Metal Deck

Model No.	Drill Bit Dia. in.	Threaded Rod Dia. in.	Embed. Depth in. (mm)	Min. Edge Dist. in. (mm)	Min. Spacing in. (mm)	Tension Load Based on Concrete Strength (Install in High Flute)		Tension Load Based on Concrete Strength (Install in Low Flute)		Tension Load Based on Rod Strength
						$f'_c \geq 3000$ psi (20.7 MPa) Concrete		$f'_c \geq 3000$ psi (20.7 MPa) Concrete		A307 (SAE 1018)
						Ultimate lbs. (kN)	Allowable lbs. (kN)	Ultimate lbs. (kN)	Allowable lbs. (kN)	Allowable lbs. (kN)
BBMD2550	1 ³ / ₁₆ -7 ¹⁶ / ₆₄	1/4	2 (51)	7 1/2 (191)	8 (203)	9,320 (41.5)	2,330 (10.4)	3,210 (14.3)	800 (3.6)	940 (4.2)
		3/8								2,105 (9.4)
		1/2								3,750 (16.7)
BBMD3762	1 1/8-1 3/8	3/8	2 (51)	7 1/2 (191)	8 (203)	10,540 (46.9)	2,635 (11.7)	3,440 (15.3)	860 (3.8)	2,105 (9.4)
		1/2								3,750 (16.7)
		5/8								5,875 (26.1)
BBMD6275	1 3/16-1 3/8	5/8	2 (51)	7 1/2 (191)	8 (203)	12,360 (55.0)	3,090 (13.7)	3,445 (15.3)	860 (3.8)	5,875 (26.1)
		3/4								8,460 (37.6)

See notes below.

Metal Deck Insert: Shear Loads in Normal-Weight or Sand-Lightweight Concrete over Metal Deck



* See page 13 for an explanation of the load table icons

Model No.	Drill Bit Dia. in.	Threaded Rod Dia. in.	Embed. Depth in. (mm)	Min. Edge Dist. in. (mm)	Min. Spacing in. (mm)	Shear Load Based on Concrete Strength (Install in High Flute)		Shear Load Based on Concrete Strength (Install in Low Flute)		Shear Load Based on Rod Strength
						$f'_c \geq 3000$ psi (20.7 MPa) Concrete		$f'_c \geq 3000$ psi (20.7 MPa) Concrete		A307 (SAE 1018)
						Ultimate lbs. (kN)	Allowable lbs. (kN)	Ultimate lbs. (kN)	Allowable lbs. (kN)	Allowable lbs. (kN)
BBMD2550	1 ³ / ₁₆ -7 ¹⁶ / ₆₄	1/2	2 (51)	7 1/2 (191)	8 (203)	9,720 (43.2)	2,430 (10.8)	2,790 (12.4)	700 (3.1)	1,930 (8.6)
BBMD3762	1 1/8-1 3/8	5/8	2 (51)	7 1/2 (191)	8 (203)	9,400 (41.8)	2,350 (10.4)	3,360 (14.9)	840 (3.7)	3,025 (13.4)
BBMD6275	1 3/16-1 3/8	3/4	2 (51)	7 1/2 (191)	8 (203)	9,720 (43.2)	2,430 (10.8)	3,360 (14.9)	840 (3.7)	4,360 (19.4)

1. Allowable load must be the lesser of the concrete or rod strength.
2. The allowable loads based on concrete strength are based on a factor of safety of 4.0.
3. Allowable loads may not be increased for short-term loading due to wind or seismic forces.
4. Anchors may be installed off-center in the flute, up to 1" from the edge of flute.
5. Shear loads shall be applied flush with metal deck surface.
6. Deck shall be 20-gauge minimum.
7. Mechanical and plumbing design codes may prescribe lower allowable loads. Verify with local codes.

Typical Metal Deck Installation

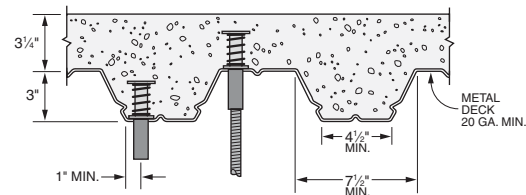

Wood Form Insert: Factory Mutual and Underwriters Laboratories Pipe Size Limits

Model No.	Rod Dia. in.	FM Max. Nominal Pipe Size in.	UL Max. Nominal Pipe Size in.
BBWF2550	1/4	N/L	4
	3/8	4	4
	1/2	8	8
BBWF3762	3/8	4	4
	1/2	8	8
	5/8	N/L	8
BBWF6275	5/8	N/L	N/L
	3/4		

1. N/L = Not listed for this pipe size.

Metal Deck Insert: Factory Mutual and Underwriters Laboratories Pipe Size Limits

Model No.	Rod Dia. in.	FM Max. Nominal Pipe Size		UL Max. Nominal Pipe Size	
		Install in High Flute in.	Install in Low Flute in.	Install in High Flute in.	Install in Low Flute in.
BBMD2550	1/4	N/L	N/L	4	4
	3/8	4	4	4	4
	1/2	8	N/L	8	4
BBMD3762	3/8	4	4	4	4
	1/2	8	N/L	8	4
	5/8	N/L	N/L	8	4
BBMD6275	5/8	12	N/L	12	N/L
	3/4	12	N/L	12	N/L

1. N/L = Not listed for this pipe size.

Easy-Set Pin-Drive Expansion Anchor

The Easy-Set is a pin drive expansion anchor for medium and heavy duty fastening applications into concrete and grout-filled block. Integrated nut and washer helps keep track of parts.

MATERIAL: Anchor body – Hot-rolled steel; Pin – Hot-wrought carbon steel

FINISH: Yellow zinc dichromate coating

INSTALLATION:

Note: Hole in fixture to be mounted must be at least 1/16" greater than the anchor diameter.

 Caution: Oversized holes in the base material will make it difficult to set the anchor and will reduce the anchor's load capacity.

- Drill a hole in the base material using a carbide drill bit the same diameter as the nominal diameter of the anchor to be installed. Drill the hole to the specified embedment depth plus 1/4" to allow for pin extension and blow it clean using compressed air. Overhead installations need not be blown clean. Alternatively, drill the hole deep enough to accommodate embedment depth and dust from drilling.
- Adjust the nut for required embedment. Place the anchor through the fixture and into the hole.
- Hammer the center pin until the bottom of the head is flush with top of anchor.



Easy-Set (EZAC)

EZAC Product Data

Size (in.)	Model No.	Min. Thread Length (in.)	Box Qty.	Carton Qty.
1/4 x 1 3/4	EZAC25134	5/8	100	500
1/4 x 2 3/8	EZAC25238	3/4	100	500
5/16 x 2 3/4	EZAC31234	1	50	250
3/8 x 2 3/8	EZAC37238	1	50	250
3/8 x 3 1/2	EZAC37312	1 1/8	50	250
3/8 x 4 3/4	EZAC37434	1 1/2	50	200
1/2 x 2 3/4	EZAC50234	1	25	125
1/2 x 3 1/2	EZAC50312	1 1/8	25	125
1/2 x 4 3/4	EZAC50434	1 1/2	25	100
1/2 x 6	EZAC50600	2	25	100
5/8 x 4	EZAC62400	1 5/8	15	60
5/8 x 4 3/4	EZAC62434	1 5/8	15	60
5/8 x 6	EZAC62600	2	15	60
3/4 x 5	EZAC75500	2	10	40
3/4 x 6	EZAC75600	2	10	40
3/4 x 7 1/2	EZAC75712	2	10	20

Installation Sequence

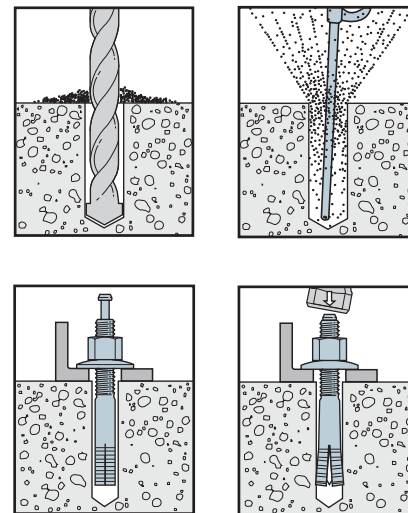

Mechanical Anchors

EZAC Tension and Shear Load Values in Normal-Weight Concrete

Size in.	Embed. Depth in. (mm)	Drill Bit Dia. in.	Critical Edge Dist. in. (mm)	Critical Spacing Dist. in. (mm)	Tension Load		Shear Load	
					f'c ≥ 2000 psi (13.8 MPa) Concrete	Allowable lbs. (kN)	f'c ≥ 2000 psi (13.8 MPa) Concrete	Allowable lbs. (kN)
1/4	1 1/8 (29)	1/4	1 3/4 (44)	3 1/2 (89)	190 (0.8)	250 (1.1)		
5/16	1 1/2 (38)	5/16	2 1/4 (57)	4 1/2 (114)	530 (2.4)	330 (1.5)		
3/8	1 3/4 (44)	3/8	2 3/4 (70)	5 1/4 (133)	630 (2.8)	645 (2.9)		
1/2	2 1/2 (64)	1/2	3 3/8 (86)	6 3/4 (171)	1,005 (4.5)	1,230 (5.5)		
5/8	3 (76)	5/8	4 1/4 (108)	9 (229)	1,515 (6.7)	1,325 (5.9)		
3/4	3 3/4 (95)	3/4	5 1/4 (133)	10 1/2 (267)	1,615 (7.2)	1,750 (7.8)		



* See page 13 for an explanation of the load table icons

1. The allowable loads listed are based on a safety factor of 4.0.
2. Allowable loads may not be increased for short-term loading due to wind or seismic forces.
3. 100% of the allowable load is permitted at critical spacing and critical edge distance. Allowable loads at lesser spacings and edge distances have not been determined.
4. The minimum concrete thickness is 1 1/2 times the embedment depth.
5. Tension and Shear loads for the EZAC Anchor may be combined using the straight-line interaction equation (n = 1).

Titen® Concrete and Masonry Screws

Titen® screws are 3/16" and 1/4" diameter hardened screws for attaching all types of components to concrete and masonry. Available in hex and phillips head designs in three colors. Use with appropriately sized Titen drill bits included with each box.

Warning: Industry studies show that hardened fasteners can experience performance problems in wet or corrosive environments. Accordingly, use these products in dry, interior and non-corrosive environments only.

MATERIAL: Heat-treated carbon steel

FINISH: Zinc plated with a baked on ceramic coating

CODES: Florida FL 2355.1

INSTALLATION:

 Caution: Industry studies show that hardened fasteners can experience performance problems in wet or corrosive environments. Steps must be taken to prevent inadvertent sustained loads above the listed allowable loads. Overtightening and bending moments can initiate cracks detrimental to the hardened screw's performance. Use the Simpson Strong-Tie installation tool kit as it has a bit that is designed to reduce the potential for overtightening the screw.

 Caution: Oversized holes in the base material will reduce or eliminate the mechanical interlock of the threads with the base material and will reduce the anchor's load capacity.

- Drill a hole in the base material using the appropriate diameter carbide drill bit as specified in the table. Drill the hole to the specified embedment depth plus 1/2" to allow the thread tapping dust to settle and blow it clean using compressed air. Overhead installations need not be blown clean. Alternatively, drill the hole deep enough to accommodate embedment depth and dust from drilling and tapping.
- Position fixture, insert screw and tighten using drill and installation tool fitted with a hex socket or phillips bit.

Preservative-treated wood applications: Suitable for use in non-ammonia formulations of CCA, ACQ-C, ACQ-D, CA-B, SBX/DOT and zinc borate. Use in dry, interior environments only. Use caution not to damage ceramic barrier coating during installation. Recommendations are based on testing and experience at time of publication and may change. Simpson Strong-Tie cannot provide estimates on service life of screws. Contact Simpson Strong-Tie for additional information.



Installation Sequence

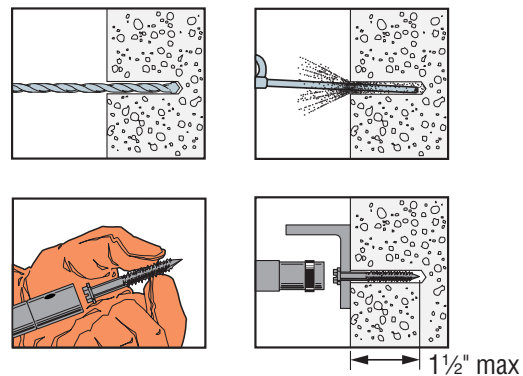

Mechanical Anchors

Titen® Tension and Shear Load Values in Normal-Weight Concrete



Titen Dia. in. (mm)	Drill Bit Dia. in.	Embed. Depth in. (mm)	Critical Spacing in. (mm)	Critical Edge Dist. in. (mm)	Tension Load				Shear Load	
					f'c ≥ 2000 psi (13.8 MPa) Concrete		f'c ≥ 4000 psi (27.6 MPa) Concrete		f'c ≥ 2000 psi (13.8 MPa) Concrete	
					Ultimate lbs. (kN)	Allowable lbs. (kN)	Ultimate lbs. (kN)	Allowable lbs. (kN)	Ultimate lbs. (kN)	Allowable lbs. (kN)
3/16 (4.8)	5/32	1 (25.4)	2 1/4 (57.2)	1 1/8 (28.6)	500 (2.2)	125 (0.6)	640 (2.8)	160 (0.7)	1,020 (4.5)	255 (1.1)
3/16 (4.8)	5/32	1 1/2 (38.1)	2 1/4 (57.2)	1 1/8 (28.6)	1,220 (5.4)	305 (1.4)	1,850 (8.2)	460 (2.0)	1,670 (7.4)	400 (1.8)
1/4 (6.4)	3/16	1 (25.4)	3 (76.2)	1 1/2 (38.1)	580 (2.6)	145 (0.6)	726 (3.2)	180 (0.8)	900 (4.0)	225 (1.0)
1/4 (6.4)	3/16	1 1/2 (38.1)	3 (76.2)	1 1/2 (38.1)	1,460 (6.5)	365 (1.6)	2,006 (8.9)	500 (2.2)	1,600 (7.1)	400 (1.8)

1. Maximum anchor embedment is 1 1/2" (38.1 mm).
2. Concrete must be minimum 1.5 x embedment.



Titen® Tension and Shear Load Values in Face Shell of Hollow and Grout-Filled CMU



Titen Dia. in. (mm)	Drill Bit Dia. in.	Embed. Depth in. (mm)	Critical Spacing in. (mm)	Critical Edge Dist. in. (mm)	Values for 6" or 8" Lightweight, Medium-Weight or Normal-Weight CMU			
					Tension Load		Shear Load	
					Avg. Ult. lbs. (kN)	Allow. lbs. (kN)	Avg. Ult. lbs. (kN)	Allow. lbs. (kN)
3/16 (4.8)	5/32	1 (25.4)	2 1/4 (57.2)	1 1/8 (28.6)	542 (2.4)	110 (0.5)	1,016 (4.5)	205 (0.9)
1/4 (6.4)	3/16	1 (25.4)	3 (76.2)	1 1/2 (38.1)	740 (3.3)	150 (0.7)	1,242 (5.5)	250 (1.1)

1. The tabulated allowable loads are based on a safety factor of 5.0 for installations under the IBC and IRC.
2. Maximum anchor embedment is 1 1/2" (38.1 mm).

*See page 13 for an explanation of the load table icons



Bulk packaging available for large-volume applications

Titen® Concrete and Masonry Screws

Standard Blue Titen® Product Data ($\frac{3}{16}$ " diameter)

Size (in.)	Model No. ¹	Bit Diameter (in.)	Quantity		
			Box ²	Carton ³	Bulk ⁴
$\frac{3}{16} \times 1\frac{1}{4}$	TTN18114H	$\frac{5}{32}$	100	1600	1000
$\frac{3}{16} \times 1\frac{3}{4}$	TTN18134H			500	
$\frac{3}{16} \times 2\frac{1}{4}$	TTN18214H			500	
$\frac{3}{16} \times 2\frac{3}{4}$	TTN18234H			500	
$\frac{3}{16} \times 3\frac{1}{4}$	TTN18314H			400	
$\frac{3}{16} \times 3\frac{3}{4}$	TTN18334H			400	
$\frac{3}{16} \times 4$	TTN18400H			400	
$\frac{3}{16} \times 1\frac{1}{4}$	TTN18114PF			1600	
$\frac{3}{16} \times 1\frac{3}{4}$	TTN18134PF			500	
$\frac{3}{16} \times 2\frac{1}{4}$	TTN18214PF			500	
$\frac{3}{16} \times 2\frac{3}{4}$	TTN18234PF			500	
$\frac{3}{16} \times 3\frac{1}{4}$	TTN18314PF			400	
$\frac{3}{16} \times 3\frac{3}{4}$	TTN18334PF			400	
$\frac{3}{16} \times 4$	TTN18400PF			400	

1. H Suffix: Hex Head, PF Suffix: Phillips Flat Head.
2. One drill bit is included in each box.
3. Cartons consist of boxes of 100.
4. Bulk Titen Screws come packed in a single carton, and do not include a drill bit. To order, add a "B" onto the end of the model number. Example: TTN18314HB.

Standard Blue Titen® Product Data ($\frac{1}{4}$ " diameter)

Size (in.)	Model No. ¹	Bit Diameter (in.)	Quantity		
			Box ²	Carton ³	Bulk ⁴
$\frac{1}{4} \times 1\frac{1}{4}$	TTN25114H	$\frac{3}{16}$	100	1600	1000
$\frac{1}{4} \times 1\frac{3}{4}$	TTN25134H			500	1000
$\frac{1}{4} \times 2\frac{1}{4}$	TTN25214H			500	1000
$\frac{1}{4} \times 2\frac{3}{4}$	TTN25234H			500	1000
$\frac{1}{4} \times 3\frac{1}{4}$	TTN25314H			400	1000
$\frac{1}{4} \times 3\frac{3}{4}$	TTN25334H			400	1000
$\frac{1}{4} \times 4$	TTN25400H			400	1000
$\frac{1}{4} \times 5$	TTN25500H			400	•
$\frac{1}{4} \times 6$	TTN25600H			400	•
$\frac{1}{4} \times 1\frac{1}{4}$	TTN25114PF			1600	1000
$\frac{1}{4} \times 1\frac{3}{4}$	TTN25134PF			500	1000
$\frac{1}{4} \times 2\frac{1}{4}$	TTN25214PF			500	1000
$\frac{1}{4} \times 2\frac{3}{4}$	TTN25234PF			500	1000
$\frac{1}{4} \times 3\frac{1}{4}$	TTN25314PF			400	1000
$\frac{1}{4} \times 3\frac{3}{4}$	TTN25334PF			400	1000
$\frac{1}{4} \times 4$	TTN25400PF			400	1000
$\frac{1}{4} \times 5$	TTN25500PF			400	•
$\frac{1}{4} \times 6$	TTN25600PF			400	•

1. H Suffix: Hex Head, PF Suffix: Phillips Flat Head.
2. One drill bit is included in each box.
3. Cartons consist of boxes of 100.
4. Bulk Titen Screws come packed in a single carton, and do not include a drill bit. To order, add a "B" onto the end of the model number. Example: TTN25314HB.

White Titen® Product Data (Phillips Flat Head)

Size (in.)	Model No.	Bit Diameter (in.)	Quantity		
			Box ¹	Carton ²	Bulk ³
$\frac{3}{16} \times 1\frac{1}{4}$	TTNW18114PF	$\frac{5}{32}$	100	1600	1000
$\frac{3}{16} \times 1\frac{3}{4}$	TTNW18134PF			500	
$\frac{3}{16} \times 2\frac{1}{4}$	TTNW18214PF			500	
$\frac{3}{16} \times 2\frac{3}{4}$	TTNW18234PF			500	
$\frac{3}{16} \times 3\frac{1}{4}$	TTNW18314PF			400	
$\frac{3}{16} \times 3\frac{3}{4}$	TTNW18334PF			400	
$\frac{3}{16} \times 4$	TTNW18400PF			400	
$\frac{1}{4} \times 1\frac{1}{4}$	TTNW25114PF			$\frac{3}{16}$	
$\frac{1}{4} \times 1\frac{3}{4}$	TTNW25134PF	500	•		
$\frac{1}{4} \times 2\frac{1}{4}$	TTNW25214PF	500	•		
$\frac{1}{4} \times 2\frac{3}{4}$	TTNW25234PF	500	•		
$\frac{1}{4} \times 3\frac{1}{4}$	TTNW25314PF	400	•		
$\frac{1}{4} \times 3\frac{3}{4}$	TTNW25334PF	400	•		
$\frac{1}{4} \times 4$	TTNW25400PF	400	•		
$\frac{1}{4} \times 5$	TTNW25500PF	400	•		
$\frac{1}{4} \times 6$	TTNW25600PF	400	•		

1. H Suffix: Hex Head, PF Suffix: Phillips Flat Head.
2. One drill bit is included in each box.
3. Cartons consist of boxes of 100.
4. Bulk Titen Screws come packed in a single carton, and do not include a drill bit. To order, add a "B" onto the end of the model number. Example: TTNW18314PFB.

Titen® Stainless-Steel Concrete and Masonry Screws

The stainless-steel Titen® screws attach various types of components to concrete and masonry in environments where a medium level of corrosion resistance is required (reference table on page 12). Available in hex and phillips head, the Titen screws are designed for use with appropriately-sized drill bits that are included with each box.

FEATURES:

- Type 410 grade stainless steel zinc plated with a protective top coat for added corrosion protection
- Suitable for concrete, brick, grout-filled CMU and hollow-block applications
- Suitable for some preservative-treated wood applications
- Available in lengths from 1 ¼" to 4"
- 5% observed red rust after 1500 hours of ASTM B117 salt spray test*.

* Salt-spray test performance is based on tests on uninstalled fasteners, and may not reflect actual performance when installed. This information is provided for comparative purposes only.

MATERIAL: Heat-treated type 410 stainless steel

FINISH: Zinc plated with a protective top coat

INSTALLATION:

 Caution: Industry studies show that hardened fasteners can experience performance problems in wet or corrosive environments. Steps must be taken to prevent inadvertent sustained loads above the listed allowable loads. Overtightening and bending moments can initiate cracks detrimental to the hardened screw's performance. Use the Simpson Strong-Tie Titen installation tool kit as it has a bit that is designed to reduce the potential for overtightening the screw.

 Caution: Oversized holes in the base material will reduce or eliminate the mechanical interlock of the threads with the base material and will reduce the anchor's load capacity.

- Drill a hole in the base material using the appropriate diameter carbide drill bit as specified in the table. Drill the hole to the specified embedment depth plus ½" to allow the thread tapping dust to settle and blow it clean using compressed air. Overhead installations need not be blown clean. Alternatively, drill the hole deep enough to accommodate embedment depth and dust from drilling and tapping.
- Position fixture, insert screw and tighten using drill and Titen screw installation tool fitted with a hex socket or phillips bit.

For contact with preservative-treated wood and untreated wood, reference the table on page 12. Use caution not to damage coating during installation. The type 410 stainless-steel Titen with a protective top coat provides "medium" corrosion protection. Recommendations are based on testing and experience at time of publication and may change. Simpson Strong-Tie cannot provide estimates on service life of screws. Contact Simpson Strong-Tie for additional information.



Titen® Stainless-Steel Hex-Head Screw (HSS)

Titen® Stainless-Steel Phillips-Head Screw (PFSS)

Installation Sequence

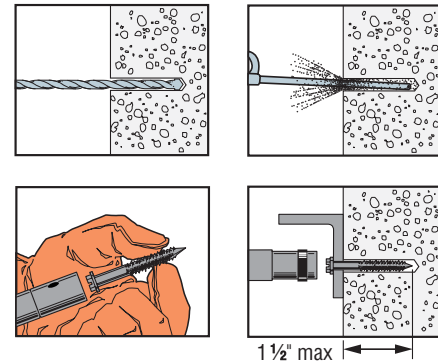

Mechanical Anchors

Type 410 Stainless-Steel Titen® Tension and Shear Load Values in Normal-Weight Concrete



Titen Dia. in. (mm)	Drill Bit Dia. in.	Embed. Depth in. (mm)	Critical Spacing in. (mm)	Critical Edge Dist. in. (mm)	Tension Load				Shear Load	
					f'c ≥ 2000 psi (13.8 MPa) Concrete		f'c ≥ 4000 psi (27.6 MPa) Concrete		f'c ≥ 2000 psi (13.8 MPa) Concrete	
					Ultimate lbs. (kN)	Allow. lbs. (kN)	Ultimate lbs. (kN)	Allow. lbs. (kN)	Ultimate lbs. (kN)	Allow. lbs. (kN)
1/4 (6.4)	3/16	1 (25.4)	3 (76.2)	1 1/2 (38.1)	600 (2.7)	150 (0.7)	935 (4.2)	235 (1.0)	760 (3.4)	190 (0.8)
1/4 (6.4)	3/16	1 1/2 (38.1)	3 (76.2)	1 1/2 (38.1)	1,040 (4.6)	260 (1.2)	1,760 (7.8)	440 (2.0)	810 (3.6)	200 (0.9)

1. Maximum anchor embedment is 1 ½" (38.1 mm).
2. Concrete must be minimum 1.5 x embedment.

Type 410 Stainless-Steel Titen® Tension and Shear Load Values in Face Shell of Hollow and Grout-Filled CMU



Titen Dia. in. (mm)	Drill Bit Dia. in.	Embed. Depth in. (mm)	Critical Spacing in. (mm)	Critical Edge Dist. in. (mm)	Values for 6" or 8" Lightweight, Medium-Weight or Normal-Weight CMU			
					Tension Load		Shear Load	
					Ultimate lbs. (kN)	Allow. lbs. (kN)	Ultimate lbs. (kN)	Allow. lbs. (kN)
1/4 (6.4)	3/16	1 (25.4)	4 (101.6)	1 1/2 (38.1)	550 (2.4)	110 (0.5)	495 (2.2)	100 (0.4)

1. The tabulated allowable loads are based on a safety factor of 5.0 for installations under the IBC and IRC.
2. Maximum anchor embedment is 1 ½" (38.1 mm).

410 Stainless-Steel Titen® Product Data

Size (in)	Head Style	Model No.	Bit Dia. (in)	Quantity	
				Box	Carton
1/4 x 1 1/4	Hex Head	TTN25114HSS	3/16	100	1600
1/4 x 1 3/4		TTN25134HSS		100	500
1/4 x 2 1/4		TTN25214HSS		100	500
1/4 x 2 3/4		TTN25234HSS		100	500
1/4 x 3 1/4		TTN25314HSS		100	400
1/4 x 3 3/4		TTN25334HSS		100	400
1/4 x 4		TTN25400HSS		100	400
1/4 x 1 1/4	Phillips Flat Head	TTN25114PFSS	3/16	100	1600
1/4 x 1 3/4		TTN25134PFSS		100	500
1/4 x 2 1/4		TTN25214PFSS		100	500
1/4 x 2 3/4		TTN25234PFSS		100	500
1/4 x 3 1/4		TTN25314PFSS		100	400
1/4 x 3 3/4		TTN25334PFSS		100	400
1/4 x 4		TTN25400PFSS		100	400

One drill bit is included in each box

*See page 13 for an explanation of the load table icons

Titen® Concrete and Masonry Screws

TITEN® SCREW – Installation Tool

Makes installation of Titen screws quick and easy. Works with drills with a standard three-jaw style chuck. Available in a rugged plastic box ideal for storage of the tool and screws. Eight piece kit includes:

- Drill bit holder
- 5/8" sleeve
- 1/4" and 5/16" hex sockets
- Phillips bit socket
- #2 & #3 Phillips bits
- Allen wrench



Titen® Screw Installation Kit (Model TTNT01)

Titen® Installation Tool

Model No.	Quantity	
	Box	Carton
TTNT01	1	24

TITEN® SCREW – Drill Bits

The same bits that come included with boxes of Titen screws are also available separately. They work with the Titen Installation Tool as well as drills with a standard three-jaw style chuck.

Titen® Drill Bits

Size (in.)	Model No.	Use With		Quantity	
		Screw	Length (in.)	Box	Carton
5/32 x 3 1/2	MDB15312	3/16" dia.	To 1 3/4	12	48
5/32 x 4 1/2	MDB15412		To 3 1/4		
5/32 x 5 1/2	MDB15512		To 4		
3/16 x 3 1/2	MDB18312	1/4" dia.	To 1 3/4		
3/16 x 4 1/2	MDB18412		To 3 1/4		
3/16 x 5 1/2	MDB18512		To 4		



Titen® Screw Drill Bit

TITEN® SCREW – SDS-Plus Drill Bit/Driver

This SDS-Plus shank bit works with the Titen Installation Tool to allow pre-drilling and installation of Titen screws using a rotohammer. *Rotohammer must be in rotation-only mode before driving screws.*



Titen® Screw Drill Bit / Driver

Special hex adaptor (included with the Titen Screw Installation Kit) allows the Titen Installation Tool to slide over the bit and lock in, ready to drive screws.



Titen® Drill Bit/Driver Product Data

Size (in.)	Model No.	For Screw Dia. (in.)	Drilling Depth (in.)	Overall Length (in.)
5/32 x 5	MDBP15500H	3/16	2 1/4	5
5/32 x 6	MDBP15600H		3 1/4	6
5/32 x 7	MDBP15700H		4 1/4	7
3/16 x 5	MDBP18500H	1/4	2 1/4	5
3/16 x 6	MDBP18600H		3 1/4	6
3/16 x 7	MDBP18700H		4 1/4	7

Titen® Drill Bit/Driver - Bulk Packs of 25

Size (in.)	Model No.	For Screw Dia. (in.)	Drilling Depth (in.)	Overall Length (in.)
5/32 x 5	MDBP15500HB	3/16	2 1/4	5
5/32 x 7	MDBP15700HB		4 1/4	7
3/16 x 5	MDBP18500HB	1/4	2 1/4	5
3/16 x 7	MDBP18700HB		4 1/4	7

1. Titen Drivers are sold individually.

Heli-Tie™ Helical Wall Tie

The Heli-Tie™ is a stainless-steel helical tie used to anchor building façades to structural members or to stabilize multiple-wythe brick walls. The helical design allows the tie to be driven quickly and easily into a predrilled pilot hole (or embedded into mortar joints in new construction) to provide a mechanical connection between a masonry façade and its backup material or between multiple wythes of brick. As it is driven, the fins of the tie undercut the masonry to provide an expansion-free anchorage that will withstand tension and compression loads. The Heli-Tie wall tie is installed using a proprietary setting tool that is used with an SDS-Plus shank rotohammer to drive and countersink the tie. Heli-Tie wall ties performs in concrete and masonry as well as wood and steel studs.



Heli-Tie™ Helical Wall Tie
U.S. Patent 7,269,987

FEATURES:

- Installs quickly and easily- With the rotohammer in drill and hammer mode the tie installs faster than competitive products.
- Provides an inconspicuous repair that preserves the appearance of the building. After installation the tie is countersunk up to 1/2" below the surface, allowing the tie location to be patched.
- Corrosion resistant stainless steel.
- Larger core diameter provides higher torsional capacity resulting in less deflection due to "uncoiling" under load.
- Fractionally sized anchor - no metric drill bits required.
- Patented manufacturing process results in a more uniform helix along the entire tie allowing easier driving and better interlock with the substrate.
- Batch number printed on every tie for easy identification and inspection.

MATERIAL: Type 304 stainless steel (type 316 available by special order, contact Simpson Strong-Tie for details)

TEST CRITERIA: CSA A370

INSTALLATION:

- Drill pilot hole through the façade material and to the specified embedment depth + 1" in the backup material using appropriate drill bit(s). Drill should be in rotation only mode when drilling into soft masonry or into hollow backing material.
- Position blue end of the Heli-Tie™ fastener in the installation tool and insert the tie into the pilot hole.
- With the SDS-PLUS rotohammer in rotation and hammer mode, drive the tie until the tip of the installation tool enters the exterior surface of the masonry and countersinks the tie below the surface. Patch the hole in the façade using a color-appropriate material.



Installation Sequence

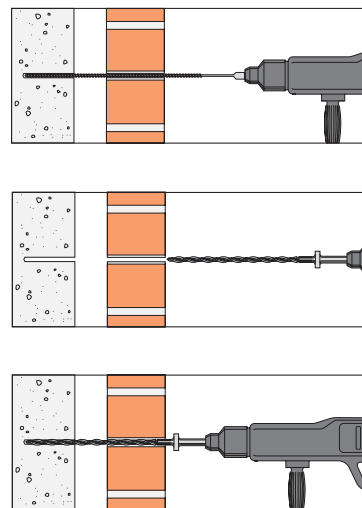

Heli-Tie™ Product Data

Size (in.)	Model No.	Drill Bit Dia. (in.)	Quantity	
			Box	Carton
3/8 x 7	HELI37700A	7/32 or 1/4	100	400
3/8 x 8	HELI37800A		100	400
3/8 x 9	HELI37900A		100	400
3/8 x 10	HELI371000A		150	300
3/8 x 11	HELI371100A		150	300
3/8 x 12	HELI371200A		150	300

Special-order lengths available, contact Simpson Strong-Tie for details.

Heli-Tie™ Fastener Installation Tool - Model HELITOO37A

Required for correct installation of Heli-Tie wall ties. Speeds up installation and automatically countersinks the tie into the façade material. The one-piece design with no moving parts improves longevity and prevents the Heli-Tie fasteners from jamming. Installation tools sold separately.



HELITOO37A

Heli-Tie™ Helical Wall Tie

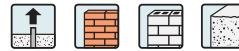

* See page 13 for an explanation of the load table icons

Guide Tension Loads in Various Base Materials

Size in. (mm)	Base Material	Anchor Location	Drill Bit Dia. in.	Min. Embed. Depth in. (mm)	Tension Load ¹				
					Ultimate ² lbs. (kN)	Load at Max. Permitted Displ. ³ lbs. (kN)	Standard Deviation lbs. (kN)		
3/8 (9.0)	Solid Brick ⁴	Mortar Bed Joint	7/32	3 (76)	570 (2.5)	240 (1.1)	79 (0.4)		
			1/4		365 (1.6)	130 (0.6)	46 (0.2)		
		Brick Face	7/32		1,310 (5.8)	565 (2.5)	84 (0.4)		
			1/4		815 (3.6)	350 (1.6)	60 (0.3)		
	Hollow Brick ⁵	Mortar Bed Joint	7/32	3 (76)	530 (2.4)	285 (1.3)	79 (0.4)		
			1/4		775 (3.4)	405 (1.8)	47 (0.2)		
		Brick Face	7/32		510 (2.3)	185 (0.8)	20 (0.1)		
			1/4		1,170 (5.2)	405 (1.8)	79 (0.4)		
	Grout-Filled CMU ⁶	Center of Face Shell	7/32	2 3/4 (70)	830 (3.7)	350 (1.6)	60 (0.3)		
			1/4		1,160 (5.2)	440 (2.0)	56 (0.2)		
		Web	7/32		810 (3.6)	330 (1.5)	100 (0.4)		
			1/4		720 (3.2)	320 (1.4)	71 (0.3)		
		Mortar Bed Joint	7/32		530 (2.4)	205 (0.9)	58 (0.3)		
			1/4		790 (3.5)	305 (1.4)	56 (0.2)		
		Hollow CMU ⁷	Center of Face Shell		7/32	2 3/4 (70)	505 (2.2)	255 (1.1)	46 (0.2)
					1/4		1,200 (5.3)	445 (2.0)	50 (0.2)
	Web		7/32	675 (3.0)	385 (1.7)		96 (0.4)		
			1/4	880 (3.9)	410 (1.8)		76 (0.3)		
	Normal-Weight Concrete ⁸	-	7/32	1 3/4 (44)	990 (4.4)	380 (1.7)	96 (0.4)		
			1/4	2 3/4 (70)	590 (2.6)	370 (1.6)	24 (0.1)		
	2x4 Wood Stud ^{9,11}	Center of Thin Edge	7/32	2 3/4 (70)	450 (2.0)	260 (1.2)	6 (0.0)		
			1/4		200 (0.9)	120 (0.5)	8 (0.0)		
	Metal Stud ^{10,11}	Center of Flange	7/32	1 (25)	155 (0.7)	95 (0.4)	2 (0.0)		
			1/4		200 (0.9)	120 (0.5)	8 (0.0)		

Caution: Loads are guide values based on laboratory testing. On-site testing shall be performed for verification of capacity since base material quality can vary widely.

1. Tabulated loads are guide values based on laboratory testing. On-site testing shall be performed for verification of capacity since base material quality can vary widely.
2. Ultimate load is average load at failure of the base material. Heli-Tie™ fastener average ultimate steel strength is 3,885 pounds and does not govern.
3. Load at maximum permitted displacement is average load at displacement of 0.157 inches (4 mm). The designer shall apply a suitable factor of safety to these numbers to derive allowable service loads.
4. Solid brick values for nominal 4-inch wide solid brick conforming to ASTM C62/C216, Grade SW. Type N mortar is prepared in accordance with IBC Section 2103.8.
5. Hollow brick values for nominal 4-inch wide hollow brick conforming to ASTM C216/C652, Grade SW, Type HBS, Class H40V. Mortar is prepared in accordance with IBC Section 2103.8.
6. Grout-filled CMU values for 8-inch wide lightweight, medium-weight and normal-weight concrete masonry units. The masonry units must be fully grouted. Values for 8-inch wide concrete masonry units (CMU) with a minimum specified compressive strength of masonry, f_m, at 28 days is 1500 psi.
7. Hollow CMU values for 8-inch wide lightweight, medium-weight and normal-weight concrete masonry units.
8. Normal-weight concrete values for concrete with minimum specified compressive strength of 2,500 psi.
9. 2x4 wood stud values for nominal 2x4 Spruce-Pine-Fir.
10. Metal stud values for 20-gauge C-shape metal stud.
11. For new construction. Anchor one end of tie into backup material. Embed other end into veneer mortar joint. Not for retrofits due to difficulty of locating center of 2x4 or metal stud flange.

C-SAS-2012 © 2012 Simpson Strong-Tie Company Inc.

Mechanical Anchors

Compression (Buckling) Loads

Size in. (mm)	Unsupported Length in. (mm)	Ultimate Compression Load ¹ lbs. (kN)
3/8 (9.0)	1 (25)	1,905 (8.5)
	2 (50)	1,310 (5.8)
	4 (100)	980 (4.4)
	6 (150)	785 (3.5)

1. The Designer shall apply a suitable factor of safety to these numbers to derive allowable service loads.



Heli-Tie™ Wall Tie Tension Tester - Model HELITEST37A

Recommended equipment for on-site testing to accurately determine load values in any specific structure. The Heli-Tie wall tie tension tester features a key specifically designed to grip the Heli-Tie fastener and provide accurate results. Replacement test keys sold separately (Model HELIKEY37A).

Crimp Multi-Purpose Anchors

The Crimp anchor is an easy-to-install expansion anchor for use in concrete and grout-filled block. The pre-formed curvature along the shaft creates an expansion mechanism that secures the anchor in place and eliminates the need for a secondary tightening procedure. This speeds up anchor installation and reduces the overall cost.

Four Crimp anchor head styles are available to handle different applications that include fastening wood or light-gauge steel, attaching concrete formwork, hanging overhead support for sprinkler pipes or suspended ceiling panels.

WARNING : Industry studies show that hardened fasteners can experience performance problems in wet or corrosive environments. Accordingly, with the exception of the duplex anchor, use these products in dry, interior and non-corrosive environments only.

MATERIAL: Carbon steel

FINISH: Zinc plated and mechanically galvanized

CODES: Factory Mutual 3031136 for the 3/8" Rod Coupler.

HEAD STYLES: Mushroom, rod coupler, tie-wire and duplex

INSTALLATION:

- Drill a hole using the specified diameter carbide bit into the base material to a depth of at least 1/2" deeper than the required embedment.
- Blow the hole clean of dust and debris using compressed air. Overhead application need not be blown clean. Where a fixture is used, drive the anchor through the fixture into the hole until the head sits flush against the fixture.
- Be sure the anchor is driven to the required embedment depth. The Rod Coupler and Tie-Wire models should be driven in until the head is seated against the surface of the base material.



Mushroom Head



Rod Coupler



Tie-Wire



Duplex

Crimp Anchor Product Data

Size	Model No.	Head Style/ Finish	Drill Bit Dia. (in.)	Min. Fixture Hole Size (in.)	Min. Embed (in.)	Quantity Box	Ctn		
3/16" x 1 1/4"	CD18114M	Mushroom Head - Zinc Plated	3/16	1/4	7/8	100	1600		
3/16" x 2"	CD18200M				1 1/4	100	500		
1/4" x 1"	CD25100M				7/8	100	1600		
1/4" x 1 1/4"	CD25114M				7/8	100	1600		
1/4" x 1 1/2"	CD25112M		1/4	5/16	1 1/4	100	1600		
1/4" x 2"	CD25200M				1 1/4	100	500		
1/4" x 2 1/2"	CD25212M				1 1/4	100	500		
1/4" x 3"	CD25300M				1 1/4	100	500		
3/8" x 2"	CD37200M				3/8	7/16	1 3/4	25	125
3/8" x 3"	CD37300M						1 3/4	25	125
1/4" x 3"	CD25300MG	Mushroom Head - Mechanically Galvanized	1/4	5/16	1 1/4	100	500		
1/4" Rod Coupler	CD25114RC	Rod Coupler - Zinc Plated	3/16	N/A	1 1/4	100	500		
3/8" Rod Coupler	CD37112RC		1/4	N/A	1 1/2	50	250		
1/4" Tie Wire	CD25118T	Tie Wire - Zinc Plated	1/4	N/A	1 1/8	100	500		
1/4" Duplex	CD25234D	Duplex Head - Zinc Plated	1/4	5/16	1 1/4	100	500		

1. Mechanical galvanizing meets ASTM B695, Class 55, Type 1. Intended for some pressure-treated wood sill plate applications. Not for use in other corrosive or outdoor environments. See page 16 for details.

Crimp Anchor Installation Sequence

Rod Coupler

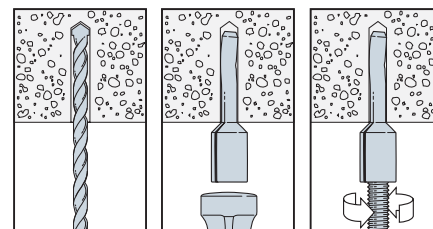

Tie-Wire

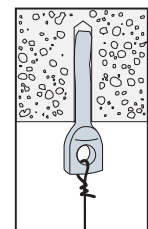

Mushroom Head

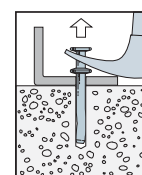
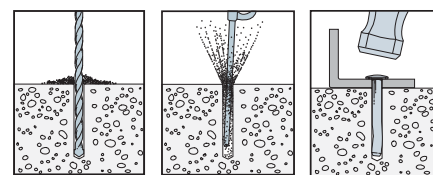

Duplex-head anchor may be removed with a claw hammer

Crimp Multi-Purpose Anchors



Tension and Shear Loads in Normal-Weight Concrete

Size (in.)	Drill Bit Dia. (in.)	Embed. Depth (in.)	Min. Spacing (in.)	Min. Edge Dist. (in.)	Tension Load		Shear Load	
					f' _c ≥ 2000 psi Concrete	f' _c ≥ 4000 psi Concrete	f' _c ≥ 2000 psi Concrete	f' _c ≥ 4000 psi Concrete
					Allowable Load (lbs.)	Allowable Load (lbs.)	Allowable Load (lbs.)	Allowable Load (lbs.)
MUSHROOM HEAD								
3/16	3/16	1 1/4	3	3	145	250	340	450
1/4	1/4	1 1/4	3	3	175	275	395	610
3/8	3/8	1 3/4	4	4	365	780	755	1305
DUPLEX HEAD								
1/4	1/4	1 1/4	3	3	175	275	395	610
TIE WIRE								
1/4	1/4	1 1/8	3	3	155	215	265	325
ROD COUPLER⁴								
1/4	3/16	1 1/4	3	3	145	250	•	•
3/8	1/4	1 1/2	4	4	265	600	•	•

1. The allowable loads listed are based on a safety factor of 4.0.
2. The minimum concrete thickness is 1 1/2 times the embedment depth.
3. Allowable loads may be linearly interpolated between concrete strengths listed.
4. For rod coupler, mechanical and plumbing design codes may prescribe lower allowable loads; verify with local codes.

*See page 13 for an explanation of the load table icons



Tension and Shear Loads in Sand-Lightweight Concrete over Metal Deck

Size (in.)	Drill Bit Dia. (in.)	Embed. Depth (in.)	Min. Spacing (in.)	Min. Edge Dist. (in.)	Tension Load (Install in Concrete)	Tension Load (Install through Metal Deck)	Shear Load (Install in Concrete)	Shear Load (Install through Metal Deck)
					f' _c ≥ 3000 psi Concrete	f' _c ≥ 3000 psi Concrete	f' _c ≥ 3000 psi Concrete	f' _c ≥ 3000 psi Concrete
					Allowable Load (lbs.)	Allowable Load (lbs.)	Allowable Load (lbs.)	Allowable Load (lbs.)
MUSHROOM HEAD								
3/16	3/16	1 1/4	4	4	115	85	345	600
1/4	1/4	1 1/4	4	4	145	130	375	890
3/8	3/8	1 3/4	5 1/2	5 1/2	315	330	1030	1085
DUPLEX HEAD								
1/4	1/4	1 1/4	4	4	145	130	375	890
TIE WIRE								
1/4	1/4	1 1/8	3	3	130	90	275	210
ROD COUPLER⁶								
1/4	3/16	1 1/4	4	4	115	85	•	•
3/8	1/4	1 1/2	5	5	300	280	•	•

1. The allowable loads listed are based on a safety factor of 4.0.
2. The minimum concrete thickness is 1 1/2 times the embedment depth.
3. Anchors may be installed off-center in the flute, up to 1" from the center of flute.
4. Anchor may be installed in either upper or lower flute.
5. Deck profile shall be 3" deep, 20-gauge minimum.
6. For rod coupler, mechanical and plumbing design codes may prescribe lower allowable loads; verify with local codes.

Length Identification Head Marks on Mushroom And Duplex-Head Crimp Anchors (corresponds to length of anchor - inches)

Mark	□	A	B	C	D
From	1	1 1/2	2	2 1/2	3
Up To But Not Including	1 1/2	2	2 1/2	3	3 1/2

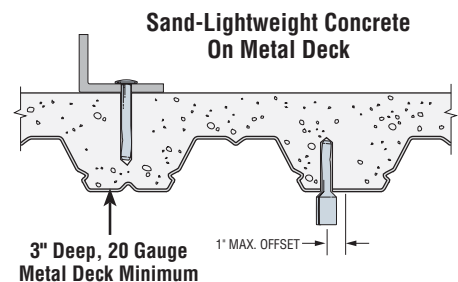

MSD/CSD/DSD Split Drive Anchors

The Split Drive anchor is a one piece anchor, with a split-type expansion mechanism on the working end. As the anchor is driven into the hole, the expansion mechanism compresses and exerts force against the walls of the hole. Can be installed in concrete, grout-filled block and stone. Available in mushroom, countersunk and duplex-head styles. The duplex head Split Drive is designed for temporary fastening applications and can be removed using a claw hammer.

Warning for CSD and MSD only: Industry studies show that hardened fasteners can experience performance problems in wet or corrosive environments. Accordingly, use these products in dry, interior and non-corrosive environments only.

MATERIAL: Heat-treated carbon steel

FINISH: Zinc plated and mechanically galvanized

INSTALLATION:

Caution: Oversized holes in the base material will reduce the anchor's load capacity. For CSD and MSD, embedment depths greater than 1½" may cause bending during installation.

- Drill a hole in the base material using a ¼" diameter carbide tipped drill. Drill the hole to the specified embedment depth and blow it clean using compressed air. Alternatively, drill the hole deep enough to accommodate embedment depth and dust from drilling. Overhead installations need not be blown clean.
- Position fixture and insert Split Drive anchor through fixture hole. For CSD and MSD, ⅜" diameter fixture hole is recommended for hard fixtures such as steel. For DSD, ⅝" diameter fixture hole is recommended.
- Drive anchor until head is flush against fixture.

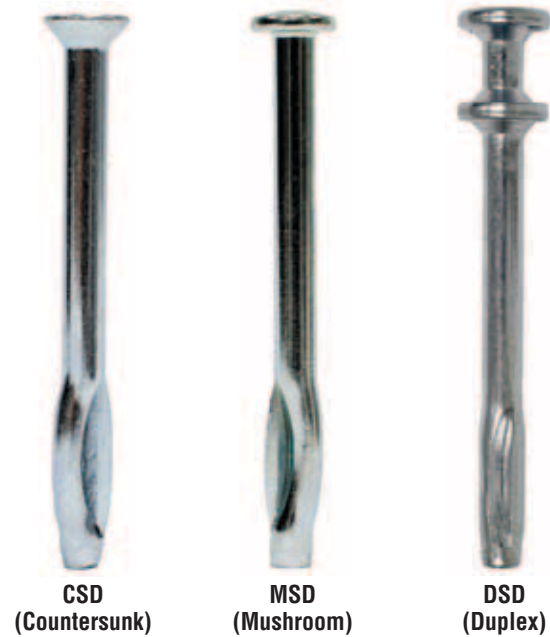

MSD/CSD/DSD Product Data

Size (in.)	Model No.	Head Style/ Finish	Drill Bit Dia. (in.)	Quantity	
				Box	Carton
¼ x 1½	MSD25112	Mushroom Head - Zinc Plated	¼	100	500
¼ x 2	MSD25200			100	500
¼ x 2½	MSD25212			100	500
¼ x 3	MSD25300			100	400
¼ x 3½	MSD25312			100	400
¼ x 4	MSD25400			100	400
¼ x 1½	CSD25112	Countersunk Head - Zinc Plated	¼	100	500
¼ x 2	CSD25200			100	500
¼ x 2½	CSD25212			100	500
¼ x 3	CSD25300			100	400
¼ x 3½	CSD25312			100	400
¼ x 4	CSD25400			100	400
¼ x 3	CSD25300MG	Countersunk Head - Mechanically Galvanized ¹	¼	100	400
¼ x 4	CSD25400MG			100	400
¼ x 3	DSD25300	Duplex Head - Zinc Plated	¼	100	400

1. Mechanical galvanizing meets ASTM B695, Class 55, Type 1. Intended for some preservative-treated wood sill plate applications. Not for use in other corrosive or outdoor environments. See page 11 for details.

Installation Sequence

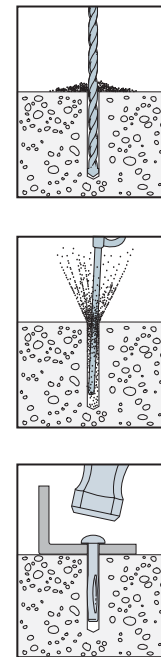

MSD & CSD Tension and Shear Load Values in Normal-Weight Concrete

Size (in.)	Drill Bit Dia. (in.)	Embed. Depth (in.)	Min. Spacing (in.)	Min. Edge Dist. (in.)	Tension Load (lbs.)		Shear Load (lbs.)	
					$f'_c \geq 2000$ psi		$f'_c \geq 2000$ psi	
					Ultimate Load	Allowable Load	Ultimate Load	Allowable Load
¼	¼	1¼	2½	3	655	165	970	240



DSD Tension and Shear Load Values in Normal-Weight Concrete

Size (in.)	Drill Bit Dia. (in.)	Embed. Depth (in.)	Min. Spacing (in.)	Min. Edge Dist. (in.)	Concrete Compressive Strength (psi)	Tension Load (lbs.)		Shear Load (lbs.)	
						$f'_c \geq 2000$ psi		$f'_c \geq 2000$ psi	
						Ultimate Load	Allowable Load	Ultimate Load	Allowable Load
¼	¼	1¼	2½	3	2500	800	200	2480	620
¼	¼	1¼	2½	3	4000	1060	265	2740	685



*See page 13 for an explanation of the load table icons

DSD anchor may be removed with a claw hammer

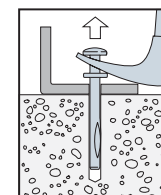

Nailon™ Pin Drive Anchors

Nylon and Zinc Nailon™ anchors are low cost anchors for light-duty applications under static loads.

SPECIAL FEATURES:

- Nylon Nailon anchor: The nylon shell acts as an insulator when used in electrical applications.
- Zinc Nailon anchor: Available with carbon and stainless-steel pins. The pin and head configuration make this anchor tamper resistant.

MATERIAL: Nylon Body: nylon – Pin – Cold-rolled steel
Zinc Body – die cast zinc alloy;
Pin – Carbon and stainless steel (Type 304)

CODES: Meets Federal Specification A-A-1925A, Type 1 (zinc mushroom),

INSTALLATION:

 **Caution:** Oversized holes will make it difficult to set the anchor and will lower the anchor's load capacity.

- Drill a hole in the base material using a carbide drill bit the same diameter as the nominal diameter of the anchor to be installed. Drill the hole to the specified embedment depth plus 1/8" for pin extension and blow it clean using compressed air. Alternatively, drill the hole deep enough to accommodate embedment depth and dust from drilling.
- Position fixture, insert Nailon anchor.
- Tap with hammer until flush with fixture; drive pin until flush with top of head.



Nylon Nailon™ Anchor (Mushroom, Round)

Zinc Nailon™ Anchor (Mushroom)

Installation Sequence

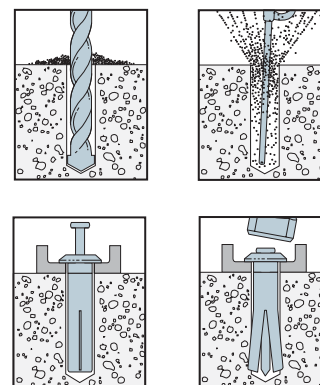

Nylon Nailon™ Product Data and Tension Loads in Normal-Weight Concrete



Head Style	Size (in.)	Model No.	Drill Bit Dia. (in.)	Embed. Depth (in.)	Allowable Tension Load (lbs.) f'c ≥ 3000 psi	Quantity	
						Box	Carton
R	3/16 x 1	N18100R	3/16	7/8	20	100	1600
M		N18100M				100	1600
R	3/16 x 1 1/2	N18112R	1/4	1 1/4	25	100	500
R	1/4 x 1	N25100R		7/8	20	100	1600
M		N25100M	100			1600	
R	1/4 x 1 1/2	N25112R	1/4	1 1/4	30	100	500
M		N25112M				100	500
M	1/4 x 2	N25200M	1/4	1 1/2	40	100	400
R		N25200R				100	400
M	1/4 x 3	N25300M	1/4	2	40	50	200

R = Round Head; M = Mushroom Head

1. Allowable loads listed are based on a safety factor of 4.0.

 Not for use in overhead applications

 These anchors are not recommended for eccentric tension (prying) loading. Capacity can be greatly reduced in such applications.

Zinc Nailon™ (Mushroom Head) Product Data and Tension and Shear Loads in Normal-Weight Concrete



Size (in.)	Carbon Steel Pin Model No.	Stainless Steel Pin Model No.	Drill Bit Dia. (in.)	Embed. Depth (in.)	Allowable Load (lbs.)		Quantity		
					f'c ≥ 3000 psi		Box	Carton	Bulk
					Tension	Shear			
3/16 x 3/8	ZN18078	•	3/16	3/4	165	120	100	1600	1000
1/4 x 3/4	ZN25034	ZN25034SS	1/4	5/8	165	120	100	1600	
1/4 x 1	ZN25100	ZN25100SS		7/8	225	225	100	500	
1/4 x 1 1/4	ZN25114	ZN25114SS		1	255	225	100	500	
1/4 x 1 1/2	ZN25112	ZN25112SS		1 1/4	285	225	100	500	
1/4 x 2	ZN25200	ZN25200SS		1 1/2	285	260	100	400	
1/4 x 2 1/2	ZN25212	ZN25212SS		2	310	260	100	400	
1/4 x 3	ZN25300	ZN25300SS		2 1/2	310	260	100	400	

*See page 13 for an explanation of the load table icons

1. The allowable loads listed are based on a safety factor of 4.0.
2. Bulk Nailon anchors come packed in a single carton of 1,000. To order add a "B" onto the end of the model number. Example: ZN25100B. Not available with stainless-steel pins.

LSES Lag Screw Expansion Shield



LSES

The Lag Screw Expansion Shield is a die cast zinc alloy expansion shield for anchoring lag screws in a variety of base materials, including concrete, concrete block, brick and mortar joints. Radial ribs provide additional holding power in softer material.

MATERIAL: Die cast Zamac 3 Alloy

INSTALLATION:

! **Caution:** Oversized holes may make it impossible to set the anchor and will reduce the anchor's load capacity.

- Drill a hole in the base material using the appropriate-diameter carbide drill bit as specified in the table. Drill the hole to the specified embedment depth plus 1/8" for flush mounting and blow it clean using compressed air. Alternatively, drill the hole deep enough to accommodate embedment depth and dust from drilling. Overhead installations need not be blown clean.
- Insert anchor into hole. Tap with hammer until flush with surface of base material.
- Position fixture; insert screw and tighten.

LSES Product Data and Tension Loads in Normal-Weight Concrete

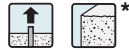

Size (in.)	Model No.	Drill Bit Dia. (in.)	Embed. Depth (in.)	Allowable Tension Load (lbs.)	Quantity	
				f'c ≥ 3000 psi	Box	Carton
1/4 Short	LSES25S	1/2	1	90	100	500
5/16 Short	LSES31S	1/2	1 1/4	100	100	500
3/8 Short	LSES37S	5/8	1 3/4	220	50	250
1/2 Short	LSES50S	3/4	2	250	25	125
1/4 Long	LSES25L	1/2	1 1/2	120	50	250
5/16 Long	LSES31L	1/2	1 3/4	150	50	250
3/8 Long	LSES37L	5/8	2 1/2	260	50	200
1/2 Long	LSES50L	3/4	3	310	25	100

*See page 13 for an explanation of the load table icons

1. The allowable loads listed are based on a safety factor of 4.0.
2. The minimum concrete thickness is 1 1/2 times the embedment depth.
3. Screw is not included.

Installation Sequence

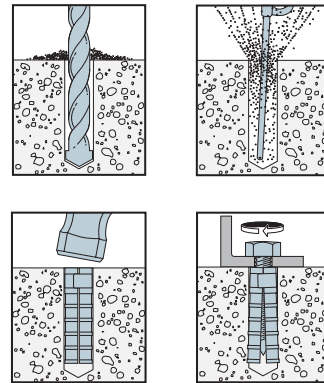

Mechanical Anchors

ESA Expansion Screw Anchor

The ESA was the original internally threaded mechanical anchor design. The malleable lead shield allows for secure mounting.

MATERIAL: Cone: Die Cast Zamac 3 alloy; Expander Shield: 3 - 5% antimonial lead

INSTALLATION:

- Drill a hole in the base material using the appropriate diameter carbide drill bit as specified in the table. Drill the hole to the specified embedment depth plus 1/8" for flush mounting. Blow the hole clean using compressed air. Overhead installations need not be blown clean.
- Insert anchor into hole.
- Using a piloted setting punch, drive expander shield over cone.
- Position fixture; insert fastener and tighten.

CODES: Meets Federal Specifications A-A-1922A, Type 1, except ESA50.

ESA Product Data and Tension Loads in Normal-Weight Concrete



Internal Thread Size (dia. - threads per inch)	Model No.	Drill Bit Dia. (in.)	Embed. Depth (in.)	Allowable Tension Load (lbs.)	Quantity	
				f'c ≥ 3000 psi	Box	Carton
#10 - 24	ESA10	3/8	5/8	140	100	1600
1/4 - 20	ESA25	1/2	7/8	190	100	500
3/8 - 16	ESA37	3/4	1 1/4	380	50	200
1/2 - 13	ESA50	7/8	1 1/2	400	50	200

1. The allowable loads listed are based on a safety factor of 4.0.
2. The minimum concrete thickness is 1 1/2 times the embedment depth.
3. Machine bolt is not included.
4. One piloted setting punch is included in each box.



ESA



Piloted Setting Punch

Installation Sequence

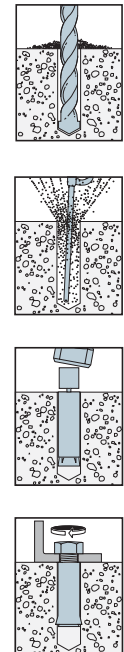

Piloted Setting Punch Product Data

Model No.	For Use With	Box Qty.
PSP10	ESA10	10
PSP25	ESA25	10
PSP37	ESA37	10
PSP50	ESA50	10

SMSA/DMSA Machine Screw Anchors

The SMSA is a corrosion resistant, die cast machine bolt anchor with a single internal expanding cone for use in concrete, concrete block and brick.

The DMSA utilizes the same basic anchor design as the SMSA but with double expansion cones to provide higher loads and better performance in base materials of questionable strength.

MATERIAL: Die cast Zamac 3 alloy

CODES: DMSA Meets Federal Specifications A-A-1923A, Type 3, except DMSA25 and DMSA31. SMSA Meets Federal Specifications A-A-1923A, Type 2

INSTALLATION:

 Caution: Oversized holes will make it difficult to set the anchor and will reduce the anchor's load capacity.

- Drill a hole in the base material using the appropriate diameter carbide drill bit as specified in the table. Drill the hole to the specified embedment depth plus 1/8" for flush mounting. Blow the hole clean using compressed air. Overhead installations need not be blown clean. Alternatively, drill the hole deep enough to accommodate embedment depth and dust from drilling.
- Insert anchor into hole. Tap with hammer until flush with surface.
- Position fixture; insert screw and tighten. The bolt must engage a minimum of 3/4" of the anchor threads.



SMSA

DMSA

Installation Sequence

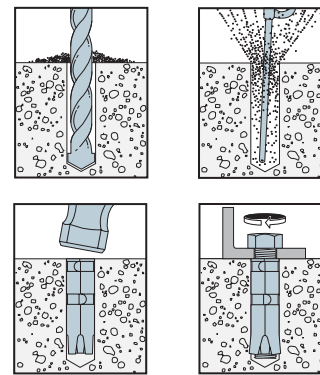

SMSA Product Data

Bolt (dia. - threads per inch)	Model No.	Drill Bit Dia. (in.)	Embed. Depth (in.)	Quantity	
				Box	Carton
1/4 - 20	SMSA25	1/2	1 3/8	100	500
5/16 - 18	SMSA31	5/8	1 3/8	100	400
3/8 - 16	SMSA37	5/8	1 3/8	50	200
1/2 - 13	SMSA50	7/8	2 1/2	25	100

1. Machine bolt is not included.

SMSA Tension Loads in Normal-Weight Concrete



Bolt (dia. - threads per inch)	Model No.	Drill Bit Dia. (in.)	Embed. Depth (in.)	Allowable Tension Load (lbs.)	Quantity	
				f'c ≥ 3000 psi	Box	Carton
1/4 - 20	SMSA25	1/2	1 3/8	235	100	500
5/16 - 18	SMSA31	5/8	1 3/8	585	100	400
3/8 - 16	SMSA37	5/8	1 3/8	585	50	200
1/2 - 13	SMSA50	7/8	2 1/2	770	25	100

1. The allowable loads listed are based on a safety factor of 4.0.
2. The minimum concrete thickness is 1 1/2 times the embedment depth.
3. Machine bolt is not included.

SMSA Tension and Shear Loads in Lightweight Hollow CMU



Bolt (dia. - threads per inch)	Model No.	Drill Bit Dia. (in.)	Embed. Depth (in.)	Allowable Tension Load (lbs.)	Allowable Shear Load (lbs.)	Quantity	
						Box	Carton
1/4 - 20	SMSA25	1/2	1 3/8	165	415	100	500
3/8 - 16	SMSA37	5/8	1 3/8	250	485	50	200

1. Values for 8-inch wide concrete masonry units. The minimum specified compressive strength of masonry is 1,900 psi.
2. Embedment depth is measured from the outside face of the concrete masonry unit for installation through a face shell.
3. The tabulated allowable loads are based on a safety factor of 5.0 for installations under the IBC and IRC.
4. All holes are drilled with a carbide-tipped drill bit in the rotation-only mode.

DMSA Product Data and Tension and Shear Loads in Normal-Weight Concrete



Bolt (dia. - threads per inch)	Model No.	Drill Bit Dia. in.	Embed. Depth in. (mm)	Critical Edge Dist. in. (mm)	Tension Load		Shear Load	Quantity	
					f'c ≥ 3000 psi (20.7 MPa)	f'c ≥ 4000 psi (27.6 MPa)	f'c ≥ 3000 psi (20.7 MPa)	Box	Carton
					Allowable lbs. (kN)	Allowable lbs. (kN)	Allowable lbs. (kN)		
1/4 - 20	DMSA25	1/2	1 1/2 (38)	3 (76)	265 (1.2)	305 (1.4)	370 (1.6)	100	500
5/16 - 18	DMSA31	5/8	1 3/4 (44)	3 1/2 (89)	290 (1.3)	335 (1.5)	690 (3.1)	100	400
3/8 - 16	DMSA37	3/4	2 1/4 (57)	4 1/2 (114)	765 (3.4)	920 (4.1)	1,300 (5.8)	50	200
1/2 - 13	DMSA50	7/8	2 3/4 (70)	5 1/2 (140)	765 (3.4)	920 (4.1)	1,770 (7.9)	25	100

*See page 13 for an explanation of the load table icons

1. The allowable loads listed are based on a safety factor of 4.0.
2. 100% of the allowable load is permitted at critical edge distance. No reduction in edge distance is allowed.
3. The minimum concrete thickness is 1 1/2 times the embedment depth.
4. Machine bolt is not included.

HWA Hollow Wall Anchors

The HWA hollow wall anchor expands inside the wall cavity to provide a large bearing area for transfer of loads.

The HWDA hollow wall drive anchor permits installation in gypsum drywall without pre-drilling.

MATERIAL: Expander shell – Cold-rolled steel

INSTALLATION:

HWA:

- Drill hole using the specified diameter bit noted in the table.
- Tap anchor into hole until flush with surface.
- Tighten screw while maintaining constant pressure on the anchor to set.
- Remove screw, install through fixture; reinsert screw into anchor body and tighten until snug against base material.

HWDA:

- Drive anchor into gypsum drywall until head is flush with surface.
- Tighten screw to set anchor.
- Remove screw, install through fixture; reinsert screw into anchor body and tighten until snug against base material.



Use caution not to over-tighten the anchor in drywall applications as this can cause crushing.

HWA Product Data

Size (in.)	Model No.	Base Material Thickness (in.)	Drill Bit Dia. (in.)	Quantity	
				Box	Carton
1/8XS	HWA12XS	1/16-1/4	5/16	100	1600
1/8S	HWA12S	1/8-1/2	5/16	100	500
1/8L	HWA12L	5/8-7/8		100	500
3/16S	HWA18S	1/8-1/2	3/8	50	250
3/16L	HWA18L	5/8-1 3/16		50	250
1/4S	HWA25S	1/8-1/2	7/16	50	250
1/4L	HWA25L	5/8-1 3/16		50	250

HWDA Kit Product Data

Size (in.)	Model No.	Base Material Thickness (in.)	Quantity	
			Box	Carton
1/8SD	HWDA12SD	1/8-1/2	100	500
1/8LD	HWDA12LD	5/8-1 3/16	100	500



HWA

HWDA

Installation Sequence

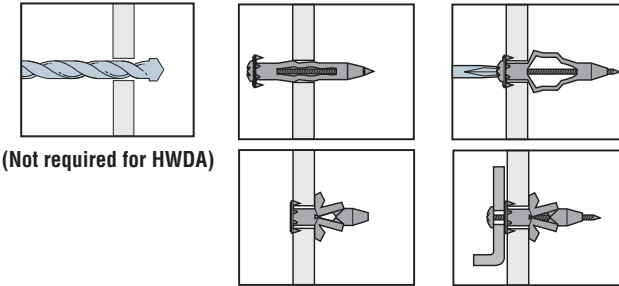

PSATG Plastic Screw Anchor

The PSATG is a plastic screw anchor that brings an innovative high-performance design to a broad range of applications and substrates, such as fastening bathroom fixtures, window treatments, picture framing and shelving.

The PSATG features "triple-grip" technology with claws on the neck that hold the anchor stationary while inserting the screw. Two expandable wings also provide gripping power, fastening tightly behind the wall for maximum holding power.

MATERIAL: Polyethylene plastic

INSTALLATIONS:

- Drill a pilot hole into the base material using the appropriate type and size of drill bit
- Insert the PSATG into the hole
- Insert the screw through the fixture and screw into the PSATG
- Turn clockwise until a firm resistance is achieved

 **Caution:** Oversized holes will make it difficult to set the anchor and will impact the anchor's performance



PSATG

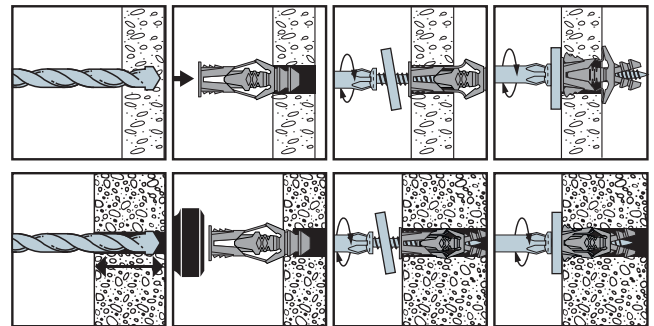

Plastic Screw Anchors with Screws Included

Screw Size	Model	Description	Drill Bit Required (in.)	Embedment Depth (in.)	Quantity		Applications
					Box	Carton	
#6 x 1 1/4	PSATG06-R200	#6 Beige	1/4	1 1/2	200	1000	3/8", 1/2", 5/8" drywall, plaster, brick, concrete, ceramic, stone
#8 x 1 1/4	PSATG08-R200	#8 Gray	1/4	1 1/2	200	1000	3/8", 1/2", 5/8" drywall, plaster, brick, concrete, ceramic, stone
#10 x 1 1/2	PSATG10-R125	#10 Blue	5/16	1 3/4	125	625	3/8", 1/2", 5/8" drywall, plaster, brick, concrete, ceramic, stone
#12 x 1 3/4	PSATG12-R70	#12 Green	3/8	2	70	350	3/8", 1/2", 5/8" drywall

Tension and Shear Loads in 1/2" Drywall ^{2,3}



* See page 13 for an explanation of the load table icons

Description	Model	Screw Size	Allowable Load ¹ (lbs.)	
			Tension	Shear
Plastic Screw Anchor - Beige	PSATG06	#6	5	35
Plastic Screw Anchor - Gray	PSATG08	#8	5	35
Plastic Screw Anchor - Blue	PSATG10	#10	10	45
Plastic Screw Anchor - Green	PSATG12	#12	15	55

1. The allowable loads listed are based on a safety factor of 4.0.
2. The allowable loads listed are based on single anchor tests.
3. The performance of multiple anchors spaced closely together has not been investigated.

Tension and Shear Loads in 2500 psi Normal-Weight Concrete



* See page 13 for an explanation of the load table icons

Description	Model	Screw Size	Drill Bit Size (in.)	Embed. Depth (in.)	Allowable Load ¹ (lbs.)	
					Tension	Shear
Plastic Screw Anchor - Beige	PSATG06	#6	1/4	1 1/2	20	100
Plastic Screw Anchor - Gray	PSATG08	#8	1/4	1 1/2	30	150
Plastic Screw Anchor - Blue	PSATG10	#10	5/16	1 3/4	35	175

1. The allowable loads listed are based on a safety factor of 4.0.
2. The allowable loads listed are based on single anchor tests.
3. The performance of multiple anchors spaced closely together has not been investigated.

Sure Wall Drywall Anchors

Sure Wall anchors are designed to self-drill into drywall and provide excellent holding value and greater capacity than screws alone. The standard Sure Wall cuts threads into drywall, greatly increasing the bearing surface and strength of the fastening. The Sure Wall Gripper expands behind the drywall, greatly increasing the bearing surface, resulting in higher loads than the standard Sure Wall. The Sure Wall Nylon Toggle has a die-cast, zinc-drilling point that toggles into position to provide the most bearing surface behind the drywall and the highest capacity in the Sure Wall product line.

FEATURES:

- Self-Drilling: Only a screwdriver needed for installation in gypsum board drywall
- Standard Sure Wall can be used as a fastener in fixtures with sufficiently large holes
- All designs maximize the load-carrying capacity of gypsum drywall
- New designs include screws with the anchors

MATERIAL:

- Sure Wall Standard: Die-cast zinc or reinforced nylon
- Sure Wall Gripper: Reinforced nylon
- Sure Wall Toggle: Reinforced nylon with a die-cast, zinc drilling point/toggle



Sure Wall Product Data

Screw Size	Model	Style	Quantity		Applications
			Box	Carton	
#6 x 1	SWN06S-R100	Nylon	100	500	3/8", 1/2" Drywall, Ceiling Tile
#8 x 1 1/4	SWN08LS-R100	Nylon	100	500	3/8", 1/2" Drywall, Ceiling Tile
#6 x 1	SWZ06S-R100	Zinc	100	500	3/8", 1/2" Drywall, Ceiling Tile, Plaster, Pegboard
#8 x 1 1/4	SWZ08LS-R100	Zinc	100	500	3/8", 1/2", 5/8" Drywall, Plaster

Standard Sure Wall Installation Sequence (Nylon or Zinc)

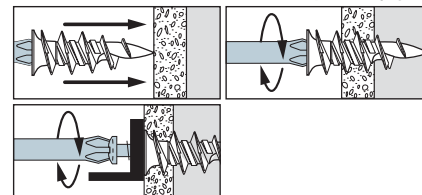

Sure Wall Tension and Shear Loads in 1/2" Drywall

Model	Screw Size	Allowable Load ¹ (lbs.)	
		Tension	Shear
SWN06S	#6	10	30
SWN08LS	#8	10	50
SWZ06LS	#6	10	30
SWZ08LS	#8	10	50



* See page 13 for an explanation of the load table icons

See notes below.

Sure Wall Gripper Product Data

Screw Size	Model	Style	Quantity		Applications
			Box	Carton	
#8 x 2"	SWNG08S-R50	Gripper Nylon	50	250	3/8", 1/2" Drywall

Sure Wall Gripper Tension and Shear Loads in 1/2" Drywall

Model	Screw Size	Allowable Load ¹ (lbs.)	
		Tension	Shear
SWNG08S	#8	25	60



* See page 13 for an explanation of the load table icons

See notes below.

Sure Wall Gripper Installation Sequence

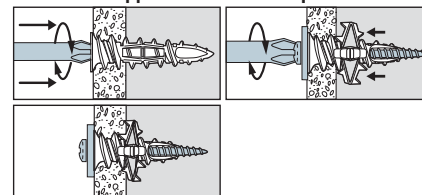

Sure Wall Nylon Toggle Product Data

Screw Size (in.)	Model	Style	Quantity		Applications
			Box	Carton	
1/8 x 2	SWNT12200-R50	Nylon Toggle	50	250	3/8", 1/2", 5/8" Drywall
1/8 x 3	SWNT12300-R50	Nylon Toggle	50	250	3/8", 1/2", 5/8" Drywall
3/16 x 2	SWNT18200-R50	Nylon Toggle	50	250	3/8", 1/2", 5/8" Drywall
3/16 x 3	SWNT18300-R50	Nylon Toggle	50	250	3/8", 1/2", 5/8" Drywall
1/4 x 3	SWNT25300-R25	Nylon Toggle	25	125	3/8", 1/2", 5/8" Drywall
1/4 x 4	SWNT25400-R25	Nylon Toggle	25	125	3/8", 1/2", 5/8" Drywall

Sure Wall Nylon Toggle Installation Sequence

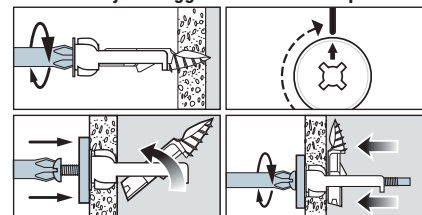

Sure Wall Nylon Toggle Tension and Shear Loads in 1/2" Drywall

Model	Screw Size (in.)	Allowable Load ¹ (lbs.)	
		Tension	Shear
SWNT12	1/8	30	50
SWNT18	3/16	35	60
SWNT25	1/4	40	80

1. The allowable loads listed are based on a safety factor of 4.0.
2. The allowable loads listed are based on single anchor tests.
3. The performance of multiple anchors spaced closely together has not been investigated.

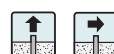

* See page 13 for an explanation of the load table icons

SWTB Spring Wing Toggle Bolts

The Spring Wing Toggle Bolt is designed for installation in hollow wall construction consisting of base materials such as gypsum wallboard and ungrouted CMU. The Spring Wing Toggle provides a large bearing area to distribute the applied loads. The Spring Wing Toggle Bolt comes complete with Spring Wing Toggle and machine screw (combo phillips and slot head). The Spring Wing Toggle may also be purchased separately (see table below).

MATERIAL: Wing – Cold-rolled steel, zinc plated
Screw – Cold-rolled steel, zinc plated

INSTALLATION:

- Drill hole using the specified diameter bit noted in the table.
- Insert screw through fixture; thread screw into toggle wing.
- Push toggle wing through drilled hole and tighten.

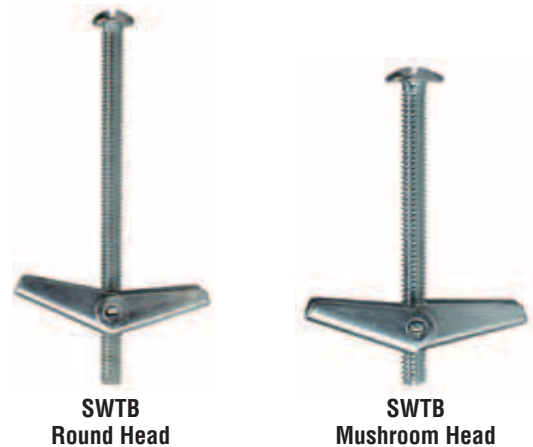

SWTB Product Data

Machine Screw		Model No.	Drill Bit Dia. (in.)	Wing Spread (in.)	Quantity	
Head ¹ Style	Size (in.)				Box	Carton
R	1/8 x 2	SWTB12200R	3/8	1 7/16	100	500
R/M ²	1/8 x 3	SWTB12300R/M ²			100	500
R	3/16 x 2	SWTB18200R	1/2	1 7/8	50	250
R/M ²	3/16 x 3	SWTB18300R/M ²			50	250
R/M ²	3/16 x 4	SWTB18400R/M ²			50	200
R	3/16 x 5	SWTB18500R			50	200
R/M ²	1/4 x 3	SWTB25300R/M ²	1 1/16	2 1/16	50	200
R/M ²	1/4 x 4	SWTB25400R/M ²			50	200
R	1/4 x 5	SWTB25500R			50	200
R	5/16 x 3	SWTB31300R	7/8	2 3/4	25	100
R	5/16 x 4	SWTB31400R			25	100
R	5/16 x 5	SWTB31500R			25	100
R	5/16 x 6	SWTB31600R			25	100
R	3/8 x 3	SWTB37300R	1	2 7/8	25	100
R	3/8 x 4	SWTB37400R			25	100
R	3/8 x 5	SWTB37500R			25	100
R	3/8 x 6	SWTB37600R			25	100

1. R = Round Head; M = Mushroom Head.
2. Models available in Round or Mushroom heads.

Installation Sequence

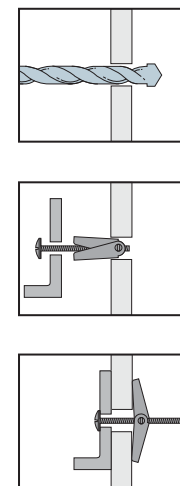

Mechanical Anchors

SWT Product Data (Toggle only)

Fits Size (dia. - threads per inch)	Model No.	Quantity		Drill Bit Dia. (in.)	Wing Spread (in.)
		Box	Carton		
#6 - 32	SWTH12	100	500	3/8	1 7/16
#10 - 24	SWTH18	100	500	1/2	1 7/8
1/4 - 20	SWTH25	25	125	1 1/16	2 1/16
5/16 - 18	SWTH31	25	125	7/8	2 3/4
3/8 - 16	SWTH37	25	125	1	2 7/8



Gas- & Powder-Actuated Fastening Systems

Time is money on the jobsite. When a contractor in the Midwest was falling behind schedule trying to tie down highway baskets, he turned to Simpson Strong-Tie. Once workers started using our PHBC powder-actuated clips, installation times dropped dramatically from about five minutes per anchor to just seconds. Find out what many other professionals already know: Simpson Strong-Tie[®] Gas- and Powder-Actuated Fastening Systems offer consistent, high-performance fastening into a variety of substrates.



GCN-MEP Gas-Actuated Concrete Nailer

The new GCN-MEP gas-actuated concrete nailer is the ideal solution for attaching light-duty fixtures to concrete and metal deck for mechanical, electrical and plumbing (MEP) applications. Since the tool does not require electrical cords or pneumatic hoses, the gas-actuated GCN-MEP is completely portable, increasing productivity.

FEATURES

- Easy magazine attachment with no extra tools
- Power to drive .125" diameter pins
- Pin-depth control dial
- Easy nose piece change-out (for .25" and .300" headed fasteners) with no extra tools
- High-voltage spark for cleaner fuel combustion
- Comfortable, "sure-grip" rubber handle
- Battery charge indicator light
- Ladder hook

SPECIFICATIONS

- Tool dimensions:
 - Length – 15.3" (439mm), 17.3" with magazine
 - Width – 4.2" (107mm)
 - Height – 15.3" (389mm)
- Tool weight: 8.3 lbs (3.7kg)
- Suitable Fasteners:
 - Length – ½" (12.7mm) to 1 ½" (38mm),
 - Diameter – For .25" and .300" headed pins
 - Magazine capacity: 40 + 2 pins*
 - Average number of shots per fuel cell: 1,200
 - Average number of shots per battery charge: 3,300
 - 6V NiMH batteries
 - Average battery charge time: 2 hours
 - Operates at temperatures between 20°F–120°F (-6°C–49°C)
 - 2 shots per second

**To ensure the tool does not discharge without pins in the magazine, all but the last two pins will be used before reloading is necessary.*

KEY FASTENING APPLICATIONS:

- Conduit clips
- Ceiling clips
- Low-voltage cable
- Cable straps
- Drywall track to concrete, steel, CMU or lightweight concrete on metal deck with magazine

THE GCN-MEP GAS-ACTUATED CONCRETE NAILER KIT INCLUDES:

- GCN-MEP nailer or GCN-MEPMAG
- 2 batteries
- Battery charger
- Allen wrenches
- Safety glasses and ear plugs
- Operator's manual/tool schematic
- Rugged tool box

Replacement Parts

Model	Description
GCN-APP012	Adaptor
GCN-CHG007	Charger (U.S.)
GCN-PPA020	Battery (U.S.)

NEW



Magazine sold separately (MEP-MAG1KT)



GCN-MEPKT
or
GCN-MEPMAGKT (with magazine)

GCN-MEP Fasteners and Accessories

GCN-MEP Gas-Actuated Pins and Assemblies for Mechanical, Electrical and Plumbing (MEP) Applications

New, pre-assembled MEP fasteners are available for use with the GCN-MEP gas-actuated concrete nailer designed for high-volume applications such as affixing conduit clips, rod hangers, cable ties and drywall track. With their .300" heads, these versatile pins and assemblies can also be used with common powder-actuated tools when fastening into harder substrates (structural steel or extra hard concrete) when required.

Codes: ICC-ES ESR-2811

Mechanical, Electrical and Plumbing Pins

All single-shot pins are .125" diameter x 1" except where specified.

Model No.	Description	Pack Qty.	Compatible Gas-Actuated Nailer
GRH25-R100	¼" Rod Hanger w/ .125" Dia. x 1" Length Pin	100	GCN-MEP, T3
GRH37-R100	⅜" rod hanger w/ .125" Dia. Shank x 1" Length Pin	100	GCN-MEP, T3

Model No.	Description	Pack Qty.	Compatible Gas-Actuated Nailer
GCC50-R100	½" Conduit Clip w/ .125" Dia. x 1" Length Pin	100	GCN-MEP, T3
GCC75-R100	¾" Conduit Clip w/ .125" Dia. x 1" Length Pin	100	GCN-MEP, T3
GCC100-R100	1" Conduit Clip w/ .125" Dia. x 1" Length Pin	100	GCN-MEP, T3
GCC125-R50	1" Conduit Clip (13 Gauge Steel) w/ .125" Dia. x 1" Length Pin	50	GCN-MEP, T3

Model No.	Description	Pack Qty.	Compatible Gas-Actuated Nailer
GCL50-R50	½" Conduit Clamp w/ .125" Dia. x 1" Length Pin	50	GCN-MEP, T3
GCL75-R25	¾" Conduit Clamp w/ .125" Dia. x 1" Length Pin	25	GCN-MEP, T3

Model No.	Description	Pack Qty.	Compatible Gas-Actuated Nailer
GAC-R100	Angle Clip w/ .125" Dia. x 1" Length Pin	100	GCN-MEP, T3

Model No.	Description	Pack Qty.	Compatible Gas-Actuated Nailer
GCT-R50	Tie Strap Holder w/ .125" Dia x 1" Length Pin	50	GCN-MEP, T3

Model No.	Description	Pack Qty.	Compatible Gas-Actuated Nailer
GW50-R200	½" Dome Washer w/ .111"/.125" Dia. x ½" Length Pin (Step Shank Pin)	200	GCN-MEP, T3
GW75-R200	½" Dome Washer w/ .125" Dia. x ¾" Length Pin	200	GCN-MEP, T3
GW100-R200	½" Dome Washer w/ .125" Dia. x 1" Length Pin	200	GCN-MEP, T3

Model No.	Description	Pack Qty.	Compatible Gas-Actuated Nailer
GTS-45075-R200	¼-20 thread, ½" length thread, ¾" length shank (.125" dia shank)	200	GCN-MEP, T3

Model No.	Description	Pack Qty.	Compatible Gas-Actuated Nailer
GBR2-R25	2" Dia. Ring, w/ .125" Dia. x 1" Length Pin	25	GCN-MEP, T3

Model No.	Description	Pack Qty.	Compatible Gas-Actuated Nailer
GTH-R200	.125" Dia. x 1" Length Pin	200	GCN-MEP, T3

GDP Strip Pins (with GCN-MEP MAGKT and 1 fuel cell)

Model No.	Description	Qty. Pins/Pack + 1 Fuel Cell	Compatible Gas-Actuated Nailer
GDP-50KT	.106" dia. x ½" pin	1,000	GCN150, GCN-MEP, TF1100, C3
GDP-562KT	.106" dia. x ⅝" pin	1,000	GCN150, GCN-MEP, TF1100, C3
GDP-75KT	.106" dia. x ¾" pin	1,000	GCN150, GCN-MEP, TF1100, C3
GDP-100KT	.106" dia. x 1" pin	1,000	GCN150, GCN-MEP, TF1100, C3
GDP-125KT	.106" dia. x 1¼" pin	1,000	GCN150, GCN-MEP, TF1100, C3
GDP-150KT	.106" dia. x 1½" pin	1,000	GCN150, GCN-MEP, TF1100, C3

Model No.	Description	Pack Qty.	Compatible Gas-Actuated Nailer
GDPS-50	1.09"/1.11" dia. x ½" pin	1,000	GCN150, GCN-MEP, TF1100, C3
GDPS-62	1.09"/1.11" dia. x ⅝" pin	1,000	GCN150, GCN-MEP, TF1100, C3
GDPS-75	1.09"/1.11" dia. x ¾" pin	1,000	GCN150, GCN-MEP, TF1100, C3

Model No.	Description	Pack Qty.	Compatible Gas-Actuated Nailer
GDPSK-137KT	.110" dia. X 1⅜" spiral knurled pin	1,000	GCN150, GCN-MEP, F100, C3

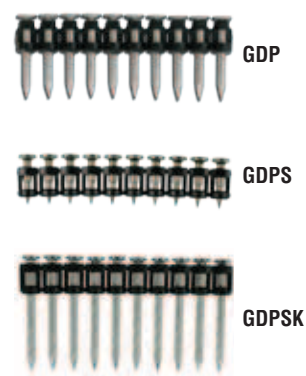
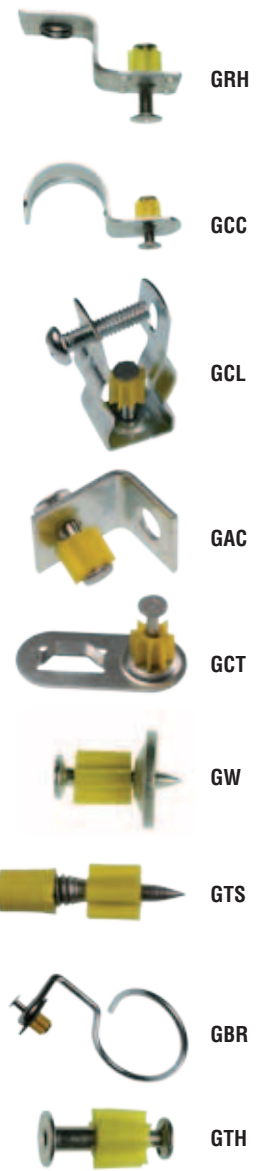

Gas and Powder-Actuated Fastening Systems

C-SAS-2012 © 2012 Simpson Strong-Tie Company, Inc.

GCN-MEP Gas-Actuated Concrete Nailer



GCN-MEP Fasteners - Tension and Shear Loads in Normal-Weight Concrete

Model No.	Shank Diameter In. (mm)	Minimum Penetration In. (mm)	Minimum Edge Distance In. (mm)	Minimum Spacing In. (mm)	Allowable Tension Load - lbs. (kN)			Allowable Shear Load - lbs. (kN)		
					f _c ≥ 2,000 psi (13.8 MPa) Concrete	f _c ≥ 3,000 psi (20.7 MPa) Concrete	f _c ≥ 4,000 psi (27.6 MPa) Concrete	f _c ≥ 2,000 psi (13.8 MPa) Concrete	f _c ≥ 3,000 psi (20.7 MPa) Concrete	f _c ≥ 4,000 psi (27.6 MPa) Concrete
GW-75, GW-100, GTH	0.125 (3.2)	5/8 (15.9)	3 (76.2)	4 (101.6)	60 (0.27)	70 (0.31)	95 (0.42)	55 (0.27)	65 (0.29)	95 (0.42)
		3/4 (19.1)	3 (76.2)	4 (101.6)	85 (0.38)	105 (0.47)	190 (0.85)	120 (0.53)	145 (0.65)	215 (0.96)

1. The fasteners must not be driven until the concrete has reached the designated minimum compressive strength.
2. Minimum concrete thickness must be three times the fastener embedment into the concrete.
3. The allowable tension and shear values are only for the fastener in the concrete. Members connected to the concrete must be investigated in accordance with accepted design criteria.



GCN-MEP Fasteners - Tension and Shear Loads in Sand-Lightweight Concrete over Metal Deck

Model No.	Shank Diameter In. (mm)	Minimum Penetration In. (mm)	Minimum Edge Distance In. (mm)	Minimum Spacing In. (mm)	Installed in Concrete		Installed Thru. 3-inch "w" deck	
					Allow. Tension Load lbs. (kN)	Allow. Shear Load lbs. (kN)	Allow. Tension Load lbs. (kN)	Allow. Shear Load lbs. (kN)
GW-75, GW-100, GTH	0.125 (3.2)	5/8 (15.9)	3 (76.2)	4 (101.6)	60 (0.27)	110 (0.49)	35 (0.16)	215 (0.96)
		3/4 (19.1)	3 (76.2)	4 (101.6)	115 (0.51)	130 (0.58)	55 (0.24)	235 (1.05)

*See page 13 for an explanation of the load table icons

1. The fasteners must not be driven through the steel deck and into the lightweight concrete until the lightweight concrete has reached the designated minimum compressive strength.
2. The allowable tension and shear values are only for the fasteners driven through the steel deck and into the lightweight concrete. Members connected by the fastener, driven through the steel deck and into the lightweight concrete, must be investigated in accordance with accepted design criteria.
3. The steel deck must have a minimum thickness of 20 gauge and a minimum yield strength of 38 ksi.
4. The fasteners must be installed through the steel deck and into the concrete at the lower flute. The fastener must be a minimum of 1 1/8" from the edge of the lower flute and 3 inches from the end of the deck.



GCN-MEP Fasteners - Tension and Shear Loads in Hollow CMU

Model No.	Shank Diameter In. (mm)	Minimum Penetration In. (mm)	Minimum Edge Distance In. (mm)	Minimum Spacing In. (mm)	Installed in CMU Face Shell	
					Allow. Tension Load - lbs. (kN)	Allow. Shear Load - lbs. (kN)
GW-75, GW-100, GTH	0.125 (3.2)	5/8 (15.9)	3 (76.2)	8 (203.2)	55 (0.24)	65 (0.29)

1. The tabulated allowable load values are for the fasteners only. Members connected to the CMU receiving elements shall be designed in accordance with the applicable code and accepted design criteria.
2. The tabulated allowable load values are for fasteners installed in hollow CMUs conforming to ASTM C 90. The minimum allowable nominal size of the CMU must be 8 inches high by 8 inches wide by 16 inches long, with a minimum, 1 1/4"-thick face shell thickness, medium-weight and normal-weight concrete masonry units.
3. The tabulated allowable load values are for fasteners installed in the center of a hollow CMU face shell.

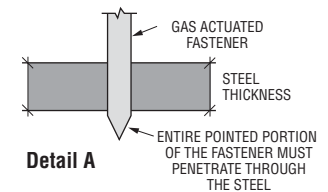

GCN-MEP Fasteners - Tension and Shear Loads in Steel



Model No.	Shank Diameter In. (mm)	Minimum Edge Distance In. (mm)	Minimum Spacing In. (mm)	Steel Thickness - (In.)					
				3/16		1/4		5/8	
				Allow. Tension Load - lbs. (kN)	Allow. Shear Load - lbs. (kN)	Allow. Tension Load - lbs. (kN)	Allow. Shear Load - lbs. (kN)	Allow. Tension Load - lbs. (kN)	Allow. Shear Load - lbs. (kN)
ASTM A36									
GW-50, GTH-50	0.111/0.125 (2.8/3.2)	1/2 (12.7)	1 (25.4)	225 (1.00)	400 (1.78)	275 (1.22)	345 (1.53)	245 ⁴ (1.09)	310 ⁴ (1.38)
ASTM A572 Grade 50 or A992									
GW-50, GTH-50	0.111/0.125 (2.8/3.2)	1/2 (12.7)	1 (25.4)	240 (1.07)	380 (1.69)	215 ⁴ (0.96) ⁴	325 ⁴ (1.45) ⁴	280 ⁴ (1.25) ⁴	350 ⁴ (1.56) ⁴

1. The entire pointed portion of the fastener must penetrate through the steel to obtain the tabulated values, see Detail A, except as noted in footnote 4.
2. The allowable tension and shear values are for the fastener only. Members connected to the steel must be separately investigated in accordance with accepted design criteria.
3. Steel must conform to ASTM A36 (F_y = 36 ksi, F_u = 58 ksi), ASTM A572 Grade 50 (F_y = 50 ksi, F_u = 65 ksi), or ASTM A992 (F_y = 50 ksi, F_u = 65 ksi).
4. Tabulated values are based on minimum penetration of the fastener point into steel of 0.25 inch (6.4mm).

GCN150 Gas-Actuated Concrete Nailer

The GCN150 gas-actuated concrete nailer is a portable fastening tool for attaching light-duty fixtures such as drywall track, furring strips, hat track and angle track to concrete, steel, CMU and metal deck. The GCN150 has a portable gas fuel supply that does not require electrical cords or hoses. The GCN150 sets up quickly and offers maximum productivity. With a 500 shot-per-hour capacity and a pin jam release door, the GCN150 makes fastening pins fast and easy. Additional attributes include two-step pin loading into the magazine, light and well-balanced weight, a battery indicator light and a sure-grip rubber handle pad.

FEATURES:

- Fast: 40-pin magazine and 1,200-shot fuel cell for reduced loading time
- Easy to use: Automatic piston reset
- Easy open jam release door
- Portable: No hoses, cords, or external energy source required
- Convenient: Simple 2-step pin loading and open-blade guide-jam release
- Easy-load fuel compartment
- No possibility of firing with no pins – when tool is down to last 2 pins in the pin magazine a "lock off" occurs
- Ladder hook

SPECIFICATIONS:

- Tool dimensions: Length – 17.3", Width – 4.2", Height – 15.3"
- Weight: 8.3 lbs
- Magazine capacity: 42
- Average number of fastens per fuel cell: 1,200
- Average number of fastens per battery charge: 3,300
- Average battery charge time: 2 hours
- Fastener type: Length – ½" to 1½"
Diameter – .102" to .109"

KEY FASTENING APPLICATIONS:

- Drywall track to concrete, steel, CMU or metal deck
- Furring strips to concrete, steel or CMU
- Plywood to concrete, steel or CMU
- Angle track to concrete, steel or metal deck

TOOL IS SOLD IN RUGGED FIXTURED TOOL BOX AND INCLUDES:

- 2 Batteries
- 1 Charger
- Safety glasses
- Ear protection
- Operators manual
- Tool schematic
- Tool cleaning instructions

Replacement Part:

Model	Description
GCN-APP012	Adaptor
GCN-CHG007	Charger (U.S.)
GCN-PPA020	Battery (U.S.)



Easy open jam release door



GCN150 Gas-Actuated Concrete Nailer

GDP Pins

GDP concrete pins are designed to work with the GCN150 and GCN-MEP (with magazine attached) gas-actuated concrete nailer tools as well as with most major brand gas concrete-nailer tools. The 10-fastener patented strip is designed with break-away plastic. The pins are designed for use in A36, A572 and A992 steel, concrete and CMU block.

Codes: ICC-ES ESR-2811; Florida FL 11506.2

.106 Diameter Shank Drive Pins for the GCN150

Model No.	Length (in.)	Qty. Pins / pack +1 Fuel Cell	Packs/ Carton	Compatible with these Tools
GDP-50KT	½	1,000	5	Simpson Strong-Tie GCN-MEP, GCN-MEPMAG GCN150 Others: TF1100, C3
GDP-62KT	⅝	1,000	5	
GDP-75KT	¾	1,000	5	
GDP-100KT	1	1,000	5	
GDP-125KT	1¼	1,000	5	
GDP-150KT	1½	1,000	5	



GDP
U.S. Patent 605016

Note: All installations are limited to dry, interior environments.

GDP Tension Loads in Normal-Weight Concrete



Shank Diameter in.	Minimum Penetration in. (mm)	Minimum Edge Distance in. (mm)	Minimum Spacing in. (mm)	Tension Loads			
				f' _c ≥ 2000 psi (13.8 Mpa)	f' _c ≥ 3000 psi (20.7 Mpa)	f' _c ≥ 4000 psi (27.6 Mpa)	f' _c ≥ 5000 psi (34.5 Mpa)
				Allow. Load lbs. (kN)	Allow. Load lbs. (kN)	Allow. Load lbs. (kN)	Allow. Load lbs. (kN)
0.106 (2.7)	⅝ (15.9)	3 (76.2)	4 (102)	25 (0.11)	30 (0.13)	45 (0.20)	45 (0.20)
	¾ (19.1)			30 (0.13)	30 (0.13)	30 (0.13)	30 (0.13)

1. The fasteners must not be driven until the concrete has reached the designated minimum compressive strength.
2. Minimum concrete thickness must be three times the fastener embedment into the concrete.
3. The allowable tension values are only for the fasteners in the concrete. Members connected to the concrete must be investigated in accordance with accepted design criteria.



GDP Shear Loads in Normal-Weight Concrete

Shank Diameter in.	Minimum Penetration in. (mm)	Minimum Edge Distance in. (mm)	Minimum Spacing in. (mm)	Shear Loads			
				f' _c ≥ 2000 psi (13.8 Mpa)	f' _c ≥ 3000 psi (20.7 Mpa)	f' _c ≥ 4000 psi (27.6 Mpa)	f' _c ≥ 5000 psi (34.5 Mpa)
				Allow. Load lbs. (kN)	Allow. Load lbs. (kN)	Allow. Load lbs. (kN)	Allow. Load lbs. (kN)
0.106 (2.7)	⅝ (15.9)	3 (76.2)	4 (102)	25 (0.11)	25 (0.11)	25 (0.11)	25 (0.11)
	¾ (19.1)			45 (0.20)	55 (0.24)	75 (0.33)	75 (0.33)

1. The fasteners must not be driven until the concrete has reached the designated minimum compressive strength.
2. Minimum concrete thickness must be three times the fastener embedment into the concrete.
3. The allowable shear values are only for the fasteners in the concrete. Members connected to the concrete must be investigated in accordance with accepted design criteria.

*See page 13 for an explanation of the load table icons

GCN150 Gas-Actuated Concrete Nailer



* See page 13 for an explanation of the load table icons

GDP Tension and Shear Loads in Sand-Lightweight Concrete

Shank Diameter in.	Minimum Penetration in. (mm)	Minimum Edge Distance in. (mm)	Minimum Spacing in. (mm)	Tension Loads		Shear Loads	
				$f'_c \geq 3000$ psi (20.7 Mpa)		$f'_c \geq 3000$ psi (20.7 Mpa)	
				Allow. Load lbs. (kN)	Allow. Load lbs. (kN)	Allow. Load lbs. (kN)	Allow. Load lbs. (kN)
0.106 (2.7)	5/8 (15.9)	3 (76.2)	4 (102)	75 (0.33)	35 (0.16)		
	3/4 (19.1)			105 (0.47)	140 (0.62)		

Note: All installations are limited to dry, interior environments.

1. The fasteners must not be driven until the lightweight concrete has reached the designated minimum compressive strength.
2. Minimum lightweight concrete thickness must be three times the fastener embedment into the lightweight concrete.
3. The allowable shear and tension values are only for the fasteners in the lightweight concrete. Members connected to the lightweight concrete must be investigated in accordance with accepted design criteria.



GDP Tension and Shear Loads in Sand-Lightweight Concrete over Metal deck

Shank Diameter in.	Minimum Penetration in. (mm)	Minimum Edge Distance in. (mm)	Minimum Spacing in. (mm)	Tension Loads – Thru 1.5" "B" Deck		Shear Loads – Thru 1.5" "B" Deck		Tension Loads – Thru 3" "W" Deck		Shear Loads – Thru 3" "W" Deck	
				$f'_c \geq 3000$ psi (20.7 Mpa)		$f'_c \geq 3000$ psi (20.7 Mpa)		$f'_c \geq 3000$ psi (20.7 Mpa)		$f'_c \geq 3000$ psi (20.7 Mpa)	
				Allow. Load lbs. (kN)	Allow. Load lbs. (kN)	Allow. Load lbs. (kN)	Allow. Load lbs. (kN)	Allow. Load lbs. (kN)	Allow. Load lbs. (kN)	Allow. Load lbs. (kN)	Allow. Load lbs. (kN)
0.106 (2.7)	5/8 (15.9)	1 (25.4)	4 (102)	65 (0.29)	195 (0.87)	60 (0.27)	180 (0.80)				
	3/4 (19.1)			130 (0.58)	270 (1.20)	60 (0.27)	180 (0.80)				

1. The fasteners must not be driven through the steel deck and into the lightweight concrete until the lightweight concrete has reached the designated minimum compressive strength.
2. The allowable tension and shear values are only for the fasteners driven through the steel deck and into the lightweight concrete. Members connected by the fastener, driven through the steel deck and into the lightweight concrete, must be investigated in accordance with accepted design criteria.
3. The steel deck must have a minimum thickness of 20 gauge and a minimum yield strength of 38 ksi.
4. The fasteners must be installed through the steel deck and into the concrete at the lower flute. The fastener must be a minimum of 1 1/4" from the edge of the lower flute and 3 inches from the end of the deck.

GDP Tension and Shear Loads in Hollow CMU

Shank Diameter in.	Minimum Penetration in. (mm)	Minimum Edge Distance in. (mm)	Minimum Spacing in. (mm)	Tension Loads		Shear Loads	
				Allow. Load lbs. (kN)		Allow. Load lbs. (kN)	
				0.106 (2.7)	5/8 (15.9)	3 (76.2)	8 (203)

* See page 13 for an explanation of the load table icons

1. The tabulated allowable load values are for the fasteners only. Members connected to the CMU receiving elements shall be designed in accordance with the applicable code and accepted design criteria.
2. The tabulated allowable load values are for fasteners installed in hollow CMUs conforming to ASTM C 90. The minimum allowable nominal size of the CMU must be 8 inches high by 8 inches wide by 16 inches long, with a minimum, 1 1/4"-thick face shell thickness, lightweight concrete masonry units.
3. The tabulated allowable load values are for fasteners installed in the center of a hollow CMU face shell.

GDP Tension and Shear Loads in A36 Steel

Shank Diameter in.	Minimum Penetration in. (mm)	Minimum Edge Distance in. (mm)	Minimum Spacing in. (mm)	Tension Loads			Shear Loads		
				1/8" Thick	3/16" Thick	1/4" Thick	1/8" Thick	3/16" Thick	1/4" Thick
				Allow. Load lbs. (kN)	Allow. Load lbs. (kN)	Allow. Load lbs. (kN)	Allow. Load lbs. (kN)	Allow. Load lbs. (kN)	Allow. Load lbs. (kN)
0.106 (2.7)	Thru	1/2 (12.7)	1 (25.4)	125 (0.56)	210 (0.93)	220 (0.98)	285 (1.27)	225 (1.00)	205 (0.91)

* See page 13 for an explanation of the load table icons

1. The entire pointed portion of the fastener must penetrate through the steel to obtain the tabulated values. See Detail A.
2. The allowable tension and shear values are for the fastener only. Members connected to the steel must be investigated separately in accordance with accepted design criteria.
3. Steel must conform to ASTM A36 specifications, with $F_y = 36$ ksi, minimum.

GDP Tension and Shear Loads in A572 Grade 50 or A992 Steel

Shank Diameter in.	Minimum Penetration in. (mm)	Minimum Edge Distance in. (mm)	Minimum Spacing in. (mm)	Tension Loads		Shear Loads	
				3/16" Thick	1/4" Thick	3/16" Thick	1/4" Thick
				Allow. Load lbs. (kN)	Allow. Load lbs. (kN)	Allow. Load lbs. (kN)	Allow. Load lbs. (kN)
0.106 (2.7)	Thru	1/2 (12.7)	1 (25.4)	225 (1.00)	185 (0.82)	250 (1.11)	145 (0.64)

1. The entire pointed portion of the fastener must penetrate through the steel to obtain the tabulated values. See Detail A.
2. The allowable tension and shear values are for the fastener only. Members connected to the steel must be investigated separately in accordance with accepted design criteria.
3. Steel must conform to ASTM A572 Grade 50 or A992 specifications, with $F_y = 50$ ksi, minimum.

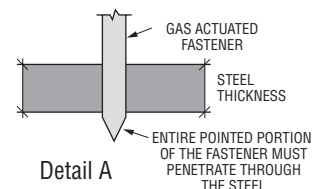

GCN150 Concrete Nailer Fasteners and Accessories

The GDPS pins are designed to work in the GCN150 and GCN-MEPMAG gas-actuated nailer tools for installation into A36, A572 Grade 50 and A992 structural steel. The step-shank pin, with smaller-diameter tip, facilitates easier penetration into the steel, while the larger diameter upper shank provides more shear resistance and successful installation.

1.09"/ 1.11" Diameter Shank Drive Pins for the GCN150

Model No.	Length (in.)	Qty. Pins/ Pack + 1 fuel cell	Pack/ Carton	Compatible Tools	
				Simpson Strong-Tie	Others
GDPS-50KT	1/2	1,000	5	GCN150 GCNMEPMAG	TF1100, C3
GDPS-62KT	5/8	1,000	5		
GDPS-75KT	3/4	1,000	5		



GDPS

GDPS Tension and Shear Loads in Steel

* See page 13 for an explanation of the load table icons

Model No.	Shank Dia. in. (mm)	Min. Penetration in. (mm)	Min. Edge Distance in. (mm)	Min. Spacing in. (mm)	Min. Steel Strength ³	Allowable Tension Loads lbs. (kN)				Allowable Shear Loads lbs. (kN)			
						Steel Thickness (in.)				Steel Thickness (in.)			
						3/16	1/4	3/8	1/2	3/16	1/4	3/8	1/2
GDPS	0.110 (2.8)	THRU	0.5 (12.7)	1.0 (25.4)	ASTM A36	95 (0.42)	170 (0.76)	165 ⁴ (0.73) ⁴	145 ⁴ (0.64) ⁴	180 (0.80)	265 (1.18)	225 ⁴ (1.00) ⁴	225 ⁴ (1.00) ⁴
	0.110 (2.8)	THRU	0.5 (12.7)	1.0 (25.4)	ASTM A572, Grade 50 or ASTM A992	110 (0.49)	170 (0.76)	155 ⁴ (0.69) ⁴	—	205 (0.91)	305 (1.36)	205 ⁴ (0.91) ⁴	—

1. The entire pointed portion of the fastener must penetrate through the steel to obtain the tabulated values, unless otherwise indicated in footnote 4.
2. The allowable tension and shear values are for the fastener only. Members connected to the steel must be investigated separately in accordance with accepted design criteria.
3. Steel strength must comply with the minimum requirements of ASTM A 36 (Fy = 36 ksi, Fu = 58 ksi) or ASTM A 572, Grade 50 (Fy = 50 ksi, Fu = 65 ksi), or ASTM A992 (Fy = 50ksi, Fu = 65 ksi)
4. Tabulated values are based on minimum penetration depth of 0.35" (8.9 mm).

Fuel Cell

The GFC34 fuel cell is designed to operate with the GCN150 and GCN-MEP Gas-Actuated Concrete Nailers and also works with many major brand gas concrete-nailer tools. The fuel cell provides 1,200 shots and can operate at temperatures between 20°–120°F (-6°–49°C). The fuel cells are offered in a 2-per-pack clamshell. Additionally, one fuel cell is included with each pack of 1,000 pins.

Gas Fuel Cells

Model No.	Description	Pack Qty.	Packs/ Carton	Compatible with these Tools
GFC34	34 gram fuel cells	12	—	Simpson Strong-Tie GCN-MEP and GCN-150
GFC34-RC2	(2) 34 gram fuel cells	2	6	Others: TrakFast® TF1100, Trak-It® C3



GFC34



GWL-100 Lathing Washer and GMR-1 Magnetic Ring

The GWL-100 lathing washer is used with the GCN150 tool and attaches lath to the wall surface for overlaying scratch coats, brown coats and stucco. The washers are held onto the nose of the tool with the GMR-1 magnetic ring and are attached to the substrate (including concrete and CMU) with GDP pins, which fasten through the washer. No extra tools are needed to install the magnetic ring to the nosepiece of the tool.

Lathing Washer and Magnetic Ring

Model No.	Description	Pack Qty.	Carton Qty.
GWL-100	Lathing Washer, 1" Dia.	1,000	5,000
GMR-1	Magnetic Ring for GCN150	10	900

Lathing Washer and Magnetic Rings are sold separately.



Gas and Powder-Actuated Fastening Systems

GCN150 Concrete Nailer Fasteners and Accessories

Spiral Knurl Gas Pins

GDPSK gas pins are designed for attaching plywood and OSB to cold-formed steel studs. The spiral knurl provides a positive lock and resists back out. Installed with the GCN150 concrete nailer or GCN-MEP (with magazine) concrete nailers, the GDPSK-138 gas pin provided faster installation and set up times, which contributes to lower labor costs. The hardened pins quickly and cleanly pierce the cold-form steel and leave the pin head flush with the wood fixture. The 1 3/8" length pin can be used for 1/2"-3/4" thick plywood, and 14-22 gauge steel.

Spiral Knurl Gas Pins

.110 Diameter Shank, .25" diameter Head, for the GCN150 or GCN-MEP with magazine

Model	Length	Qty pins/ pack + 1 fuel cell	Packs/Carton	Compatible with these Tools
GDPSK-138KT	1 3/8"	1,000	5	Simpson Strong-Tie: GCN-150, GCN-MEP w/ magazine. Others: TF1100, C3

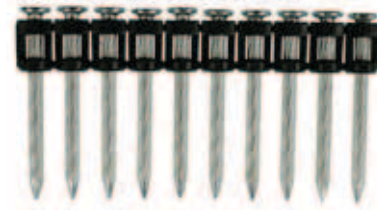

GDPSK

Spiral Knurl Pin Tension and Shear Loads in Structural Steel Studs, 33 ksi Minimum Yield Strength



Model No.	Shank Diameter in. (mm)	Minimum Edge Dist. in. (mm)	Minimum Spacing in. (mm)	Designation Thickness mils (gauge)	Allowable Loads	
					Tension lbs. (kN)	Shear lbs. (kN)
GDPSK-138	0.109 (2.77)	13/16 (20.6)	4 (101.6)	33 (20)	30 (0.13)	70 (0.31)
				43 (18)	48 (0.21)	89 (0.40)

* See page 13 for an explanation of the load table icons

1. Entire pointed portion of the fastener must penetrate through the steel to obtain tabulated values.
2. The allowable tension and shear values are for the fastener only. Members connected to the steel must be investigated separately in accordance with accepted design criteria.
3. Fastener is to be installed in the center of the stud flange.

Spiral Knurl Pin Tension and Shear Loads in Structural Steel Studs, 50 ksi Minimum Yield Strength



Model No.	Shank Diameter in. (mm)	Minimum Edge Dist. in. (mm)	Minimum Spacing in. (mm)	Designation Thickness mils (gauge)	Allowable Loads	
					Tension lbs. (kN)	Shear lbs. (kN)
GDPSK-138	0.109 (2.77)	13/16 (20.6)	4 (101.6)	54 (16)	92 (0.41)	150 (0.67)
				68 (14)	73 (0.32)	218 (0.97)

1. Entire pointed portion of the fastener must penetrate through the steel to obtain tabulated values.
2. The allowable tension and shear values are for the fastener only. Members connected to the steel must be investigated separately in accordance with accepted design criteria.
3. Fastener is to be installed in the center of the stud flange.

Important Information Powder-Actuated Fastening Systems

Gas- and Powder-Actuated Fastening Safety Principles

Before operating any Simpson Strong-Tie Anchor Systems® gas- or powder-actuated tool, you must read and understand the Operator's Manual and be trained by an authorized instructor in the operation of the tool. Simpson Strong-Tie highly recommends you read and fully understand the safety guidelines of the tool you use. You must then pass a test and receive a certified operator card to become a Certified Operator of Simpson Strong-Tie tools. The test and Operator's Manual are included with each tool kit and extra copies can be obtained by contacting Simpson Strong-Tie at (800)999-5099.

GENERAL SAFETY

To avoid serious injury or death:

- ALWAYS make sure that the operator and bystanders wear safety glasses. Hearing and head protection are also recommended.
- ALWAYS post warning signs when gas- or powder-actuated tools are in use. Signs should state "Tool in Use" and should be posted within the area where the tool is being used.
- ALWAYS store gas-and powder-actuated tools unloaded. Tools and powder loads should be stored in a locked container out of the reach of children.
- NEVER place any part of your body over the front muzzle of the tool even if no fastener is present. The fastener, pin or tool piston can cause serious injury or death in the event of an accidental discharge.
- NEVER transport fasteners or other hard objects in the same pocket or container with powder loads or fuel cells. These objects may strike the energy source, or puncture the fuel cell, thereby igniting and causing serious injury or death.
- NEVER attempt to bypass or circumvent any of the safety features on a powder- or a gas-actuated tool.
- ALWAYS keep the tool pointed in a safe direction.
- ALWAYS keep your finger off the trigger.
- ALWAYS keep the tool unloaded until ready to use.

INSTALLATION SAFETY

To avoid serious injury or death:

- ALWAYS hold the tool perpendicular (90°) to the fastening surface to prevent ricocheting fasteners. Use the spall guard whenever possible.
- NEVER attempt to fasten into soft, thin, brittle or very hard materials such as drywall, light gauge steel, glass, tile or cast iron as these materials are inappropriate. Conduct a pre-punch test to determine base material adequacy.
- NEVER attempt to fasten into soft material like wood or drywall (fastening through soft materials into an appropriate base material may be allowed if the application is appropriate).
- NEVER attempt to fasten to a spalled, cracked or uneven surface.

Safety equipment, such as safety glasses and ear plugs, are recommended when using powder-actuated tools.



Extension Poles for Gas- and Powder-Actuated Tools

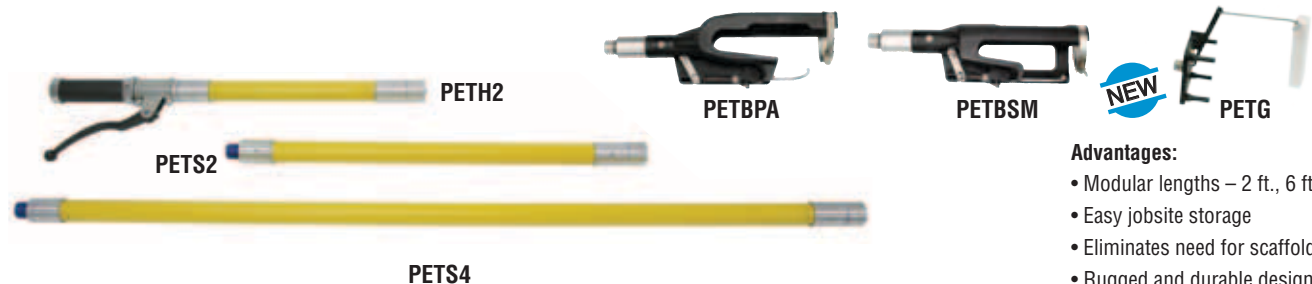

Advantages:

- Modular lengths – 2 ft., 6 ft., 8 ft.
- Easy jobsite storage
- Eliminates need for scaffolding
- Rugged and durable design

Extension Pole Tool for PTP-27, PTP-27L and PTP-27S

Model	Description	Length
PET-6PKT	Complete 6 ft. tool, with boot, handle and 1 extension	6 ft.
PET-8PKT	Complete 8 ft. tool, with boot, handle and 2 extensions	8 ft.
PETH2	Handle	2 ft.
PETBPA	Tool boot for PTP tool series	N/A
PETS2	Pole extension	2 ft.
PETS4	Pole extension	4 ft.

Extension Pole Tool for PT-27





Model	Description	Length
PET-6SMKT	Complete 6 ft. tool, with boot, handle and 1 extension	6 ft.
PET-8SMKT	Complete 8 ft. tool, with boot, handle and 2 extensions	8 ft.
PETH2	Handle	2 ft.
PETBSM	Tool boot for standard and modular tools	N/A
PETS2	Pole extension	2 ft.
PETS4	Pole extension	4 ft.

Extension Poles for GCN-MEP, GCN150

Model	Description	Length
PETG-6-KT	Complete 6 ft. tool, with boot, handle and one extension	6 ft.
PETG-8-KT	Complete 8 ft. tool, with boot, handle and two extensions	8 ft.
PETH2	Handle	2 ft.
PETG	Boot	N/A
PETS2	Pole extension	2 ft.
PETS4	Pole extension	4 ft.

Tool Application Matrix Powder-Actuated Fastening Systems







This matrix matches Simpson Strong-Tie® powder-actuated tools with the trades that would typically use each tool. The selection is based upon the features of the tool matching the needs of the trade.

	Premium Tools			
	PTP-27L (Page 192)	PTP-27LMAGR (Page 192)	PTP-27S (Page 193)	PTP-27SMAGR (Page 193)
				
FEATURES	<ul style="list-style-type: none"> • Automatic • Adjustable Power • Low Recoil/Noise • 2 1/2" Pin Capacity (4" Pin w/Washer) 	<ul style="list-style-type: none"> • Fully Automatic • 10-Fastener Magazine • Adjustable Power • Low Recoil/Noise • 2 7/8" Pin Capacity 	<ul style="list-style-type: none"> • Automatic • Adjustable Power • Low Recoil/Noise • Drywall Track Tool • 1 5/8" Pin Capacity 	<ul style="list-style-type: none"> • Fully Automatic • Rotating Fastener Magazine • 10-Fastener Magazine • Adjustable Power • Low Recoil/Noise • 1 1/4" Pin Capacity
DRYWALL	Good	Good	Best	Best
ELECTRICAL	Better		Better	
GENERAL	Best	Best		
FRAMER	Best	Best		
PLUMBING/ FIRE SPRINKLER				
ACOUSTICAL/ OVERHEAD	Good		Best	
REMODELING	Better	Better		
CARPENTRY	Better	Better		
FLOORING	Better	Better	Good	Good
GLAZING			Better	
HVAC	Better		Best	
RENTAL	Better			

Gas and Powder-Actuated Fastening Systems

Tool Application Matrix Powder-Actuated Fastening Systems

This matrix matches Simpson Strong-Tie® powder-actuated tools with the trades that would typically use each tool. The selection is based upon the features of the tool matching the needs of the trade.

	Heavy-Duty Tool	General-Purpose Tools				
	PT-27HD (Page 194)	PT-27 (Page 195)	PT-22 (Page 196)	PT-22GS (Page 197)	PT-22H (Page 198)	PT-22P (Page 199)
						
FEATURES	<ul style="list-style-type: none"> • Heavy Duty • Single .27 Caliber Shot - Long • Reliable Design • 3/8" Threaded Stud Sprinkler Tool with Stop Spall 	<ul style="list-style-type: none"> • Semi-Automatic • Versatile • Reliable Professional Grade Tool • 2 1/2" Pin Capacity (4" Pin w/ Washer) 	<ul style="list-style-type: none"> • Single Shot • Economical Professional-Grade Tool • 3" Pin Capacity (4" Pin w/ Washer) 	<ul style="list-style-type: none"> • Single Shot • Inline Trigger Tool - Easier to use than hammer-hit tool • Medium Duty • 3" Pin Capacity (4" Pin w/ Washer) 	<ul style="list-style-type: none"> • Single Shot • Hammer Activated • Medium Duty • 2 1/2" Pin Capacity 	<ul style="list-style-type: none"> • Single Shot • Versatile, Professional Grade Tool • 1 1/2" Pin Capacity • 2" Pin w/ washer
DRYWALL		Good				Best
ELECTRICAL		Good	Good	Good	Good	Better
GENERAL		Better	Good	Good		
FRAMER		Good	Good	Good		
PLUMBING/ FIRE SPRINKLER	Best					Good
ACOUSTICAL/ OVERHEAD		Better	Good	Good		Better
REMODELING		Better	Best	Best	Best	Good
CARPENTRY		Best	Better	Better	Better	
FLOORING	Best					
GLAZING		Good	Good	Good		Better
HVAC		Better				
RENTAL						

Tool / Load / Fastener Matrix Powder-Actuated Fastening Systems

This matrix matches Simpson Strong-Tie® Powder-Actuated Tools with the powder loads and fasteners that would typically be used with each tool.

Fasteners	Page No.	Premium Tools			
		PTP-27L (Page 192)	PTP-27LMAGR (Page 192)	PTP-27S (Page 193)	PTP-27SMAGR (Page 193)
Loads					
P22AC1 thru 4	200				
P25SL3 thru 5	200				
P27SL2 thru 5	200	All	All	All	All
P27SL6	200	Yes	Yes	Yes	Yes
P27LVL3 thru 6	200				
.300 Headed Pins					
PDP-XXX	201	Max 2 ½"		Max 1 ½"	
PDPA-XXX	201	Max 2 ½"		All	
PDPH-XXX	201	All		Max 1 ½"	
PDPW-XXX	202	All		Max 2"	
PDPWL-XXX	202	All		Max 2"	
PDPHWL-XXX	202	All		Max 2"	
PDPWLMG-XXX	202	All		Max 2"	
PINW-XXX	202	All		Max 2"	
PINWP-XXX	203	Max 2 ½"		Max 1 ½"	
PDPT-XXX	203	All		All	
PHBC-XXX	203	Max 2 ½"		Max 1 ½"	
PBXDP-XXX	203	All		All	
PCCXX- DPXX	203	All		All	
PECLDP-XXX	203	All		All	
PCLDP-XXX	203	All		All	
PSLV4-XXXXXX	204	All		Max 1 ½"	
8mm Headed Pins					
PHN-XXX	204	Max 2 ½"		Max 1 ⅝"	
PHNW-XXX	205	All		Max 2"	
PHNT-XXX	205	All		All	
PHSNA-XXX	206		Max 2 ⅞"		Max 1 ¼"
PTRHX-HN32	206	All		All	
PKP-250	206	All			
¾" Headed Pins / Threaded Studs					
PHV3-XXX	203				
PSLV3-XXXXXX	204				

Tool / Load / Fastener Matrix Powder-Actuated Fastening Systems

This matrix matches Simpson Strong-Tie® Powder-Actuated Tools with the powder loads and fasteners that would typically be used with each tool.

Fasteners	Page No.	Heavy-Duty Tool	General-Purpose Tools				
		PT-27HD (Page 194)	PT-27 (Page 195)	PT-22 (Page 196)	PT-22GS (Page 197)	PT-22H (Page 198)	PT-22P (Page 199)
LOADS							
P22AC1 thru 4	200			All	All	All	
P25SL3 thru 5	200						
P27SL2 thru 5	200		All				
P27SL6	200						
P27LVL3 thru 6	200	All					
.300 HEADED PINS							
PDP-XXX	201	All	Max 2 ½"	All	All	Max 2 ½"	Max 2 ½"
PDPA-XXX	201		All	All	All	Max 2 ½"	All
PDPH-XXX	201		Max 2 ½"	Max 2 ½"	All	Max 2 ½"	Max 2 ½"
PDPW-XXX	202		All	All	All	All	All
PDPWL-XXX	202		All	All	All	All	All
PDPHWL-XXX	202		All	All	All	All	All
PDPWLMG-XXX	202		All	All	All	All	All
PINW-XXX	202		All	All	All	All	All
PINWP-XXX	203		Max 2 ½"	All	All	All	Max 2 ½"
PDPT-XXX	203		All	All	All	All	All
PHBC-XXX	203		Max 2 ½"	All	All	All	Max 2 ½"
PBXDP-XXX	203		All	All	All	All	All
PCCXXX-DPXXX	203		All	All	All	All	All
PECLDP-XXX	203		All	All	All	All	All
PCLDP-XXX	203		All	All	All	All	All
PSLV4-XXXXXX	204	All	All	All	All	All	All
8MM HEADED PINS							
PHN-XXX	204	All	Max 2 ½"	All	All	All	Max 2 ½"
PHNW-XXX	205		All	All	All	All	All
PHNT-XXX	205		All	All	All	All	All
PHSNA-XXX	206						
PTRHX-HN32	206		All	All	All	All	All
PKP-250	206		All	All			All
3/8" HEADED PINS / THREADED STUDS							
PHV3-XXX	203	All					
PSLV3-XXXXXX	204	All					

PTP-27L & PTP-27LMAGR Premium Tools

FEATURES:

- **PTP-27L:** Automatic fastening: no sliding barrel, just load and shoot
- **PTP-27LMAGR:** Fully automatic tool with fastener magazine
- Can be converted to a single-shot tool

BOTH TOOLS FEATURE:

- Adjustable power for fastening versatility
- Easy disassembly for cleaning and maintenance
- No manual resetting of piston required
- Operator comfort: cushioned grip, reduced recoil and sound dampening muffler for quiet operation

SPECIFICATIONS:

- Fastener Length: PTP-27L – ½" thru 2 ½" (3" or 4" washered) PTP-27LMAGR – ⅝" thru 3"
- Fastener Type: .300" or 8mm diameter
- Firing Action: PTP-27L – Automatic PTP-27LMAGR – Fully automatic
- Load Caliber: .27 strip loads, brown through purple (Levels 2–6)
- Length: 17 ¼" (PTP-27L), 19 ½" (LMAGR)
- Weight: PTP-27L – 6.5 lbs. PTP-27LMAGR – 8.8 lbs.

KEY FASTENING APPLICATIONS:

- Wood-framing applications
- Washered-pin installation (PTP-27S and PTP-27L only)
- Insulation fastening (PTP-27S and PTP-27L only)
- Forming work

TOOL IS SOLD IN A RUGGED TOOL BOX COMPLETE WITH:

- Operator's manual
- Spall suppressor
- Tools for disassembly
- Safety glasses / ear plugs
- Tool lubricant
- Cleaning brushes
- Operator's exam and caution sign
- Tool box also sold separately
- Gloves

OPTIONS:

- Extension pole tool for the PTP-27L available in 6' and 8' lengths.
- 6' Tool: PET-6PKT; 8' Tool: PET-8PKT
- Single shot conversion kit (PTP-27LXCON)



The patent pending, quick-disconnect baseplate makes it easy to convert the PTP-27LMAGR from a magazine to a single-shot tool



Extension Pole Tool (for the PTP-27L) - See page 187 for details



The full line of Simpson Strong-Tie® Powder Loads and Fasteners begins on page 200.

Common Repair Parts - PTP-27L

Description	Model No.
Baseplate	PTP-274800
Nosepiece	PTP-273820
Piston	PTP-273320
Piston Disc	PTP-273306
Rubber Returner	PTP-274305

Common Repair Parts - PTP-27LMAGR

Description	Model No.
Magazine (Complete)	PTP-LMAGR
Nosepiece	PTP-276820
Nosepiece Screw	PTP-275826
Piston	PTP-276320
Piston Disc	PTP-273306
Rubber Returner	PTP-274305

1. See page 207 for tool repair and maintenance kits. Complete tool schematics and parts list available at www.strongtie.com.

PTP-27S & PTP-27SMAGR Premium Tools

FEATURES:

- **PTP-27S:** Automatic fastening: no sliding barrel, just load and shoot
- **PTP-27SMAGR:** Fully automatic tool with rotating fastener magazine
- Can be converted to a single shot tool

Both Tools Feature:

- Adjustable power for fastening versatility
- Operator comfort: cushioned grip, reduced recoil and sound dampening muffler for quiet operation
- No manual resetting of piston required
- Easy disassembly for cleaning and maintenance

SPECIFICATIONS:

- Fastener Length: PTP-27S – ½" thru 1 5/8"
PTP-27SMAGR – ½" thru 1 ¼"
- Fastener Type: .300" or 8mm diameter
- Firing Action: PTP-27S – Automatic
PTP-27SMAGR – Fully automatic
- Load Caliber: .27 strip loads, brown through red (Levels 2–6)
- Length: 16 ¾" (PTP-27S), 17 ½" (LMAGR)
- Weight: PTP-27S – 6.25 lbs.
PTP-27SMAGR – 8.1 lbs.

KEY FASTENING APPLICATIONS:

PTP-27S:

- Conduit clips
- Ceiling clips
- Drywall track
- Metal decking

PTP-27SMAGR:

- Drywall track
- Hat channel
- HVAC duct straps

TOOL IS SOLD IN A RUGGED TOOL BOX COMPLETE WITH:

- Operator's manual
- Spall suppressor
- Tools for disassembly
- Safety glasses / ear plugs
- Tool lubricant
- Cleaning brushes
- Operator's exam and caution sign
- Tool box also sold separately
- Gloves

OPTIONS:

- Extension pole tool for the PTP-27S available in 6' and 8' lengths.
6' Tool: PET-6PKT
8' Tool: PET-8PKT
- Single shot conversion kit (PTP-27SCON)



Adjustable power increases versatility



Rotating magazine allows for installation flexibility



The patent-pending quick-disconnect baseplate makes it easy to convert the PTP-27SMAGR from a magazine to a single shot tool



Collated pins for fully automatic fastening and quick loading



Extension Pole Tool (for the PTP-27S) - See page 187 for details



The full line of Simpson Strong-Tie® Powder Loads and Fasteners begins on page 200.

Common Repair Parts - PTP-27S

Description	Model No.
Baseplate	PTP-273800
Nosepiece	PTP-273820
Piston	PTP-273320
Piston Disc	PTP-273306
Rubber Returner	PTP-273305

Common Repair Parts - PTP-27SMAGR

Description	Model No.
Magazine Body	PTP-741000
Nosepiece	PTP-740001
Nosepiece Screw	PTP-750002
Piston	PTP-842001
Piston Disc	PTP-730071CH
Rubber Returner	PTP-742101

1. See page 207 for tool repair and maintenance kits. Complete tool schematics and parts list available at www.strongtie.com.

PT-27HD 1/4" and 3/8" Heavy-Duty Stud Driver

FEATURES:

- Low recoil when setting 3/8" fasteners into steel or hard concrete
- Consistent and reliable performance
- Easy disassembly for cleaning and maintenance

SPECIFICATIONS:

- Fastener Length: 1/2" thru 3"
- Fastener Types: 3/8" heavy-duty drive pins, .177 shank pins, 1/4"-20 threaded studs and 3/8"-16 threaded studs
- Firing Action: Single shot
- Load Caliber: .27 long single loads, green through purple (Levels 3-6)
- Length: 14 1/4"
- Weight: 8 lbs., 13 oz.

KEY FASTENING APPLICATIONS:

- 3/8" sprinkler fastenings
- Heavy-duty fastening into concrete strengths up to 8,000 psi, and structural steel

TOOL IS SOLD IN A RUGGED TOOL BOX COMPLETE WITH:

- Operator's manual
- Spall suppressor
- 8mm and 10mm fastener guides
- 8mm and 10mm pistons
- Small baseplate
- Stabilizer
- Ramrod
- Tools for disassembly
- Safety glasses / ear plugs
- Tool lubricant
- Cleaning brushes
- Operator's exam and caution sign
- 2 extra stop rings



PT-27HD

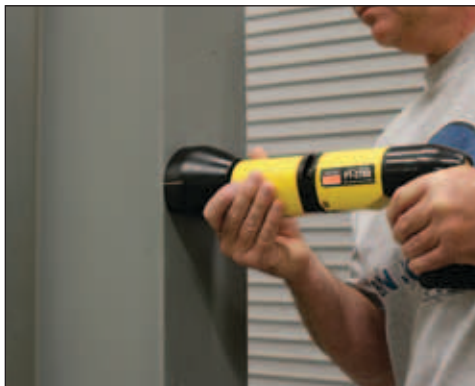

Common Repair Parts - PT-27HD

Description	Model No.
8mm Piston	PTHD-P8
8mm Fastener Guide	PTHD-G8
10mm Piston	PTHD-P10
10mm Fastener Guide	PTHD-G10
Stop Ring	PTHD-SR

The full line of Simpson Strong-Tie® Powder Loads and Fasteners begins on page 200.

PT-27 General-Purpose Tool

FEATURES:

- Reliable design of the world's most popular tool
- Semi-automatic and fast cycling
- Engineered for continuous use, high reliability and low maintenance

SPECIFICATIONS:

- Fastener Length: ½" through 2½" (3" or 4" washered)
- Fastener Type: .300" or 8mm headed fasteners or ¼"-20 threaded studs
- Firing Action: Semi-automatic
- Load Caliber: .27 strip loads, brown through red (Levels 2–5)
- Length: 13½"
- Weight: 5 lbs., 4 oz.

KEY FASTENING APPLICATIONS:

- Acoustical ceilings
- Electrical applications
- Framing members
- Drywall track
- Water proofing material and/or lathing

TOOL IS SOLD IN A RUGGED TOOL BOX COMPLETE WITH:

- Operator's manual
- Spall suppressor
- Tools for disassembly
- Safety glasses / ear plugs
- Tool lubricant
- Cleaning brushes
- Operator's exam and caution sign

OPTION:

- Extension pole tool available in 6' and 8' lengths.
6' Tool: PET-6SMKT
8' Tool: PET-8SMKT



PT-27



Gas and Powder-Actuated Fastening Systems

Common Repair Parts

Description	Model No.
Annular Spring	PT-301014
Ball Bearing (6mm)	PT-301013
Barrel	PT-301006
Baseplate	PT-301009
Piston - Concave (includes ring)	PT-301217
Piston - Flat (includes ring)	PT-301903
Piston Ring	PT-301208
Piston Stop	PT-301012
Shear Clip	PT-301011

1. See page 207 for tool repair and maintenance kits. Complete tool schematics and parts list available at www.strongtie.com.



The full line of Simpson Strong-Tie® Powder Loads and Fasteners begins on page 200.



Extension Pole Tool - See page 187 for details

PT-22 General-Purpose Tool

FEATURES:

- Single-shot firing
- Engineered for continuous use, high reliability and low maintenance

SPECIFICATIONS:

- Fastener Length: 1/2" through 2 1/2" (3" & 4" washered)
- Fastener Type: .300" or 8mm headed fasteners or 1/4"-20 threaded studs
- Load Caliber: .22 single loads, gray through yellow (Levels 1-4). Note: Not for use with 22 caliber straight wall loads
- Length: 13 7/8"
- Weight: 4.25 lbs.

KEY FASTENING APPLICATIONS:

- Furring strips
- Framing pins
- Electrical boxes
- Ceiling clips

TOOL IS SOLD IN A RUGGED TOOL BOX COMPLETE WITH:

- Operator's manual
- Spall suppressor
- Tools for disassembly
- Safety glasses / ear plugs
- Cleaning brushes
- Operator's exam and caution sign

*These items not supplied with the PT-22-RB retail package.



PT-22



Gas and Powder-Actuated Fastening Systems

Common Repair Parts

Description	Model No.
Nosepiece	PTM-DC106
Piston Buffer	PTM-01114
Piston Reset Cap	PTM-03108 ¹
Piston Reset Pin	PTM-01107 ²
Piston Reset Spring	PTM-03122 ³
Piston with Ring	PT-DC112

1. Model PT-DC108 for tools with a serial number below 5000.
2. Model PT-DC107 for tools with a serial number below 5000.
3. Model PT-DC122 for tools with a serial number below 5000.
4. See page 207 for tool repair and maintenance kits. Complete tool schematics and parts list available at www.strongtie.com.



The PT-22 is sold individually in a tool box with accessories or in a retail package (see below).

PT-22 Retail Package Product Data

Description	Model No.	Qty. of Tools Per Retail Package	Qty. of Retail Packages Per Carton
.22 Caliber, Single-Shot, Trigger-Activated Tool	PT-22-RB	1	2



PT-22-RB

The full line of Simpson Strong-Tie® Powder Loads and Fasteners begins on page 200.

PT-22GS General-Purpose Tool - Grip Shot™

FEATURES:

- Barrel trigger allows for safe and easy operation
- Medium-duty tool designed for ease of use, low maintenance and economy

SPECIFICATIONS:

- Fastener Length: ½" through 3" (4" washered)
- Fastener Type: .300" or 8mm headed fasteners or ¼"-20 threaded studs
- Firing Action: Single shot
- Load Caliber: .22 single "A" crimp loads, gray through yellow (Levels 1-4). Note: Not for use with .22 caliber straight wall loads
- Length: 17"
- Weight: 6 lbs.

KEY FASTENING APPLICATIONS:

- Framing members
- Furring strips
- Electrical boxes
- Ceiling clips



PT-22GS

PT-22GS Grip Shot™ Product Data

Description	Model No.	Qty. of Tools Per Retail Package	Qty. of Retail Packages Per Carton
.22 Caliber, Single-Shot, Barrel-Trigger Tool	PT-22GS-RB	1	2



The barrel trigger allows for easier and safer fastening.

The full line of Simpson Strong-Tie® Powder Loads and Fasteners begins on page 200.



The PT-22GS-RB is packaged in a retail clamshell ready for merchandising.

PT-22H General-Purpose Tool

FEATURES:

- Hammer activated
- Engineered for low maintenance and economy
- Four levels of power: Gray through yellow loads (levels 1–4)

SPECIFICATIONS:

- Fastener Length: 1/2" through 3"
- Fastener Type: .300" or 8mm headed fasteners or 1/4"-20 threaded studs
- Firing Action: Single-shot, hammer-activated
- Load Caliber: .22 single "A" crimp loads, gray through yellow (Levels 1–4). Note: Not for use with .22 caliber straight wall loads
- Length: 14 1/4"
- Weight: 2 lbs., 12 oz.

KEY FASTENING APPLICATIONS:

- Remodeling
- Maintenance
- Electrical
- Telecommunications



PT-22H



PT-22H Retail Package Product Data

Description	Model No.	Qty. of Tools Per Retail Package	Qty. of Retail Packages Per Carton
.22 Caliber, Single-Shot Hammer-Activated Tool	PT-22H-RB	1	4

The full line of Simpson Strong-Tie® Powder Loads and Fasteners begins on page 200.



The PT-22H-RB comes packaged in a retail clamshell ready for merchandising.

PT-22P Powder-Actuated Tool

The PT-22P is a single-shot fastening tool engineered for continuous use, high reliability and low maintenance. The all-aluminum body of the PT-22P also provides rugged durability.

KEY FASTENING APPLICATIONS:

- Drywall track
- Furring strips
- Framing pins
- Electrical boxes
- Ceiling clips

SPECIFICATIONS:

- Fastener Length: ½"-1½"
- Fastener Type: .300" or 8mm headed fasteners or ¼"-20 threaded studs
- Firing Action: Single shot
- Load Caliber: .22 single loads, gray through yellow (Levels 1-4). Note: Not for use with 22 caliber straight wall loads
- Length: 14"
- Weight: 4 lbs. 7 oz.

TOOL IS SOLD IN A RUGGED TOOL BOX

- Complete with:
- Operator's manual
- Spall suppressor
- Tools for disassembly
- Safety glasses / ear plugs
- Cleaning brushes
- Operator's exam and caution sign
- One additional piston



PT-22P



The PT-22P is sold individually in a tool box with accessories.

Common Repair Parts

Description	Model No.
Nosepiece	PT-22P-01
Stop Pin Cover	PT-22P-17
Barrel Stop Pin	PT-22P-20
Barrel Stop Pin Spring	PT-22P-21
Piston with Ring	PT-22P-02

The full line of Simpson Strong-Tie® Powder Loads and Fasteners begins on page 200.

Powder Loads For Simpson Strong-Tie® Powder-Actuated Tools

.22 Caliber "A" Crimp Loads – Single Shot

Description	Model	Pack Qty.	Carton Qty.	Compatible Tools	
				Simpson Strong-Tie	Others
.22 Cal. - Gray (Level 1)	P22AC1	100	10,000	PT-22 PT-22GS PT-22H	721, U-2000, DX-37E, DX72E, 4170 and model 70, System 3 and most low-velocity, single-shot tools
.22 Cal. - Brown (Level 2)	P22AC2	100	10,000		
.22 Cal. - Green (Level 3)	P22AC2A-R100	100	100		
	P22AC3	100	10,000		
.22 Cal. - Yellow (Level 4)	P22AC3A-R100	100	100		
	P22AC4	100	10,000		
	P22AC4-R100	100	100		



P22AC

.22 Caliber Straight Wall Loads – Single Shot

Description	Model	Pack Qty.	Carton Qty.	Compatible Tools
.22 Cal. - Yellow (Level 4)	P22LRSC4	100	10,000	Ladd Tools and some special application tools.
.22 Cal. - Red (Level 5)	P22LRSC5	100	10,000	
.22 Cal. - Purple (Level 6)	P22LRSC6	100	10,000	
.22 Cal. - Gray (Level 7)	P7LRSC	100	10,000	

Note:
Not for use with Simpson Strong-Tie PT-22, PT-22GS, or PT-22H tools.



P22LRSC

.25 Caliber Plastic 10-Shot Strip Loads

Description	Model	Pack Qty.	Carton Qty.	Compatible Tools
.25 Cal. - Green (Level 3)	P25SL3	100	10,000	DX-35, R35S
.25 Cal. - Green BULK PACK	P25SL3M	1,000	5,000	
.25 Cal. - Yellow (Level 4)	P25SL4	100	10,000	
.25 Cal. - Yellow BULK PACK	P25SL4M	1,000	5,000	
.25 Cal. - Red (Level 5)	P25SL5	100	10,000	
.25 Cal. - Red BULK PACK	P25SL5M	1,000	5,000	



P25SL

.27 Caliber Single Shot Loads – Long

Description	Model	Pack Qty.	Carton Qty.	Compatible Tools	
				Simpson Strong-Tie	Others
.27 Cal. - Green (Level 3)	P27LVL3	100	10,000	PT-27HD	HG-100 DX-600N MD-380 R6000
.27 Cal. - Yellow (Level 4)	P27LVL4	100	10,000		
.27 Cal. - Red (Level 5)	P27LVL5	100	10,000		
.27 Cal. - Purple (Level 6)	P27LVL6	100	10,000		



P27LVL

.27 Caliber Plastic, 10-Shot Strip Loads

Description	Model	Pack Qty.	Carton Qty.	Compatible Tools	
				Simpson Strong-Tie	Others
.27 Cal. - Brown (Level 2)	P27SL2	100	10,000	PTP-27L, PTP-27MAGR, PTP-27S, PTP-27SMAGR, PT-27	DX-350, DX-351, DX-36, DX-A40 (except PT27SL2), DX-A41 (except PT27SL2 and PT27SL3), DX-460, DX-450, DX-451, System 1H, P-36B, A-40B, A-41B, Cobra and most .27 caliber-clone tools
	P27SL2A-R100	100	100		
.27 Cal. - Green (Level 3)	P27SL3	100	10,000		
	P27SL3A-R100	100	100		
.27 Cal. - Green BULK PACK	P27SL3M	1,000	5,000		
.27 Cal. - Yellow (Level 4)	P27SL4	100	10,000		
	P27SL4A-R100	100	100		
.27 Cal. - Yellow BULK PACK	P27SL4M	1,000	5,000		
.27 Cal. - Red (Level 5)	P27SL5	100	10,000		
	P27SL5A-R100	100	100		
.27 Cal. - Red BULK PACK	P27SL5M	1,000	5,000		
.27 Cal. - Purple (Level 6)	P27SL6	100	10,000		DX-450, DX-451, DX-A41



P27SL

Fasteners For Simpson Strong-Tie® Powder-Actuated Tools

.300" Headed Fasteners with .157" Shank Diameter

PDPA Drive Pins - For Structural Steel and Extra Hard Concrete

- For A36 and A572 Grade 50 structural steel (red strip load recommended)
- .157 diameter for greater compressive strength
- Manufactured with tight tolerances for superior performance

Length (in.)	Model	Pack Qty	Carton Qty	Compatible Tools	
				Simpson Strong-Tie	Others
½	PDPA-50	100	1,000	PTP-27L, PTP-27S, PT-27, PT-22P PT-22, PT-22GS, PT-22H, PT-27HD,	721**, D-60, U-2000, System 1, System 3 and most other low-velocity tools.
½ knurled	PDPA-50K	100	1,000		
½ knurled	PDPA-50KM	1,000	5,000		
⅝ knurled	PDPA-62K	100	1,000		
⅝ knurled	PDPA-62KM	1,000	5,000		
¾	PDPA-75	100	1,000		
¾	PDPA-75M	1,000	5,000		
1	PDPA-100	100	1,000		
1¼	PDPA-125	100	1,000		
1½	PDPA-150	100	1,000		
1⅞	PDPA-178	100	1,000		
2	PDPA-200	100	1,000		
2½	PDPA-250	100	1,000		
2⅞	PDPA-278	100	1,000		



PDPA

.300" Headed Fasteners with .145" Shank Diameter

Length (in.)	Model	Pack Qty.	Carton Qty.	Compatible Tools	
				Simpson Strong-Tie	Others
1	PDP-100	100	1,000	PTP-27L* PTP-27S** PT-27* PT-22 PT-22GS PT-22H	721**, D-60, U-2000, System 1, System 3 and most other low-velocity tools.
1 - BULK PACK	PDP-100M	-	1,000		
1¼	PDP-125	100	1,000		
1½	PDP-150	100	1,000		
1¾	PDP-175	100	1,000		
2	PDP-200	100	1,000		
2¼	PDP-225	100	1,000		
2½	PDP-250	100	1,000		
3	PDP-300	100	1,000		



PDP

See pages 208 - 210 and 213 for load value information.

.300" Headed Fasteners with .177" Shank Diameter

Length (in.)	Model	Pack Qty.	Carton Qty.	Compatible Tools	
				Simpson Strong-Tie	Others
½	PDPH-50	100	1,000	PTP-27L* PTP-27S** PT-27* PT-22P PT-22 PT-22GS PT-22H	721**, D-60, U-2000, System 1, System 3 and most other low-velocity tools.
½ Knurled	PDPH-50K	100	1,000		
⅝ Knurled	PDPH-62K	100	1,000		
¾	PDPH-75	100	1,000		
1	PDPH-100	100	1,000		
1¼	PDPH-125	100	1,000		
1½	PDPH-150	100	1,000		
1¾	PDPH-175	100	1,000		
2	PDPH-200	100	1,000		
2½	PDPH-250	100	1,000		
3	PDPH-300	100	1,000		



PDPH

See pages 210 and 213 for load value information.

316 Stainless Steel .300" Headed Fasteners with .145" Shank Diameter

Length (in.)	Model	Pack Qty.	Carton Qty.	Compatible Tools	
				Simpson Strong-Tie	Others
½	PDP-50SS	100	1,000	PTP-27L* PTP-27S** PT-27* PT-22P PT-22 PT-22GS PT-22H	721**, D-60, U-2000, System 1, System 3 and most other low-velocity tools.
½ Knurled	PDP-50KSS	100	1,000		
⅝ Knurled	PDP-62KSS	100	1,000		
¾	PDP-75SS	100	1,000		
1	PDP-100SS	100	1,000		
1¼	PDP-125SS	100	1,000		
1½	PDP-150SS	100	1,000		
1¾	PDP-175SS	100	1,000		
2	PDP-200SS	100	1,000		
2½	PDP-250SS	100	1,000		
3	PDP-300SS	100	1,000		



PDPSS

See page 209 for load value information.

*Up to 2½", ** Up to 1½"

*Up to 2½", ** Up to 1½"

Fasteners For Simpson Strong-Tie® Powder-Actuated Tools

.300" Headed Fasteners with .145" Shank Diameter – Mechanically Galvanized

Length (in.)	Model	Pack Qty.	Carton Qty.	Compatible Tools	
				Simpson Strong-Tie	Others
2	PDP-200MG	100	1,000	PTP-27L*, PTP-27S**, PT-27*	721**, D-60, U-2000, System 1, System 3 and most other low velocity tools.
2½	PDP-250MG	100	1,000	PT-22P, PT-22, PT-22GS, PT-22H	
3	PDP-300MG	100	1,000		



PDPMG

Mechanical Galvanizing meets ASTM B695, Class 65, Type 1. *Up to 2½", **Up to 1½"

.300" Headed Fasteners with .177" Shank Diameter – Mechanically Galvanized

Length (in.)	Model	Pack Qty.	Carton Qty.	Compatible Tools	
				Simpson Strong-Tie	Others
2	PDPH-200MG	100	1,000	PTP-27L, PT-27HD, PT-27	721*, D-60, U-2000, System 1, System 3 and most other low velocity tools.
2½	PDPH-250MG	100	1,000	PT-22P, PT-22	
3	PDPH-300MG	100	1,000	PT-22GS, PT-22H	



PDPHMG

Mechanical Galvanizing meets ASTM B695, Class 65, Type 1. *Up to 2½", **Up to 1½"

.300" Headed Fasteners with .145" Shank Diameter and ¾" Metal Washers

See pages 209 for load value information.

Length (in.)	Model	Pack Qty.	Carton Qty.	Compatible Tools	
				Simpson Strong-Tie	Others
¾	PDPW-75	100	1,000		721*, D-60, U-2000, System 1, System 3 and most other low velocity tools.
1	PDPW-100	100	1,000	PTP-27L, PTP-27S*	
1¼	PDPW-125	100	1,000	PT-27	
1½	PDPW-150	100	1,000	PT-22P	
2	PDPW-200	100	1,000	PT-22, PT-22GS	
2½	PDPW-250	100	1,000	PT-22H	
3	PDPW-300	100	1,000		
3	PDPW-300	100	1,000		



PDPW

*Up to 2"

.300" Headed Fasteners with .145" Shank Diameter and 1" Metal Washers

See page 209 for load value information.

Length (in.)	Model	Pack Qty.	Carton Qty.	Compatible Tools	
				Simpson Strong-Tie	Others
1	PDPWL-100	100	1,000		721*, D-60, U-2000, System 1, System 3 and most other low velocity tools.
1¼	PDPWL-125	100	1,000		
1½	PDPWL-150	100	1,000	PTP-27L, PTP-27S*	
2	PDPWL-200	100	1,000	PT-27	
2½	PDPWL-250	100	1,000	PT-22P	
3	PDPWL-300	100	1,000	PT-22, PT-22GS	
3	PDPWL-300M	–	1,000	PT-22H	
4	PDPWL-400	100	1,000		
4	PDPWL-400	100	1,000		
4	PDPWL-400	100	1,000		



PDPWL

*Up to 2"

.300" Headed Fasteners with .145" Shank Diameter and 1" Metal Washers – Mechanically Galvanized with Protective Sleeve

- Provides added corrosion protection in preservative-treated lumber. Visit www.strongtie.com for corrosion information.
- Plastic sleeve protects and preserves coating during installation; washer will not scrape off coating.
- Plastic sleeve prevents washer slipping during installation.

Length (in.)	Model	Pack Qty.	Carton Qty.	Compatible Tools	
				Simpson Strong-Tie	Others
2	PDPWL-200MG	100	1,000	PTP-27L, PTP-27S*	721*, D-60, U-2000, System 1, System 3 and most other low velocity tools.
2½	PDPWL-250MG	100	1,000	PT-27, PT-22P	
3	PDPWL-300MG	100	1,000	PT-22, PT-22GS	
3	PDPWL-300MG	100	1,000	PT-22H	
3	PDPWLS-300MG	–	1,000		
3	PDPWLS-300MG	–	1,000		



PDPWLMG
U.S. Patent 8,066,463

Mechanical Galvanizing meets ASTM B695, Class 65, Type 1. *PDPWLS has a square washer.

.300" Headed Fasteners with 1" Metal Washers with .177" Shank Diameter

Length (in.)	Model	Pack Qty.	Carton Qty.	Compatible Tools	
				Simpson Strong-Tie	Others
1	PDPHWL-100	100	1,000		721*, D-60, U-2000, System 1, System 3 and most other low velocity tools.
1¼	PDPHWL-125	100	1,000	PTP-27L, PTP-27S	
1½	PDPHWL-150	100	1,000	PT-27	
2	PDPHWL-200	100	1,000	PT-27HD, PT-22P	
2½	PDPHWL-250	100	1,000	PT-22	
3	PDPHWL-300	50	500	PT-22GS	
4	PDPHWL-400	50	500	PT-22H	
4	PDPHWL-400	50	500		



PDPHWL

*Up to 2"

.300" Headed Fasteners with .145" Shank Diameter and 1¼" Metal Washers

Length (in.)	Model	Pack Qty.	Carton Qty.	Compatible Tools	
				Simpson Strong-Tie	Others
1	PINW-100	50	500		721, D-60, U-2000, System 1, System 3 and most other low velocity tools.
1¼	PINW-125	50	500		
1½	PINW-150	50	500	PTP-27L, PT-27	
1¾	PINW-175	50	500	PT-22P	
2	PINW-200	50	500	PT-22	
2¼	PINW-225	50	500	PT-22GS	
2½	PINW-250	50	500	PT-22H	
3	PINW-300	50	500		
3	PINW-300	50	500		
3	PINW-300	50	500		



PINW

316 Stainless Steel .300" Headed Fasteners with .145" Shank Diameter and 1" Metal Washers*

See page 209 for load value information.

Length (in.)	Model	Pack Qty.	Carton Qty.	Compatible Tools	
				Simpson Strong-Tie	Others
1	PDPWL-100SS	100	1,000		721**, D-60, U-2000, System 1, System 3 and most other low velocity tools.
1¼	PDPWL-125SS	100	1,000	PTP-27L, PTP-27S**	
1½	PDPWL-150SS	100	1,000	PT-27	
2	PDPWL-200SS	100	1,000	PT-22P	
2½	PDPWL-250SS	100	1,000	PT-22, PT-22GS	
3	PDPWL-300SS	100	1,000	PT-22H	
4	PDPWL-400SS	100	1,000		
4	PDPWL-400SS	100	1,000		



PDPWL-SS

*Washers are 304 Stainless Steel, **Up to 2"

Fasteners For Simpson Strong-Tie® Powder-Actuated Tools

See page 211 for load value information.

.300" Headed Fasteners with .145" Shank Diameter and 1 3/4" Plastic White Washers

Length (in.)	Model	Pack Qty.	Carton Qty.	Compatible Tools	
				Simpson Strong-Tie	Others
1	PINWP-100W	50	500	PTP-27L* PT-27* PT-22P PT-22 PT-22GS PT-22H	721*, D-60, U-2000, System 1, System 3 and most other low-velocity tools.
1 1/4	PINWP-125W	50	500		
1 1/2	PINWP-150W	50	500		
1 3/4	PINWP-175W	50	500		
2	PINWP-200W	50	500		
2 1/2	PINWP-250W	50	500		
3	PINWP-300W	50	500		



PINWP

*Up to 2 1/2"

.300" Headed Tophat Fasteners with .145" Shank Diameter

Length (in.)	Model	Pack Qty.	Carton Qty.	Compatible Tools	
				Simpson Strong-Tie	Others
1/2 Knurled	PDPT-50K	100	1,000	PTP-27L PTP-27S PT-27 PT-22, PT-22P PT-22GS PT-22H	721, D-60, U-2000, System 1, System 3 and most other low-velocity tools.
5/8 Knurled	PDPT-62K	100	1,000		
3/4	PDPT-75	100	1,000		
1	PDPT-100	100	1,000		



PDPT

Highway Basket Clips – .300" Headed Fasteners with .145" Shank Diameter

Description	Model	Pack Qty.	Carton Qty.	Compatible Tools	
				Simpson Strong-Tie	Others
Clip with 1 1/2" Pin	PHBC-150	100	1,000	PTP-27L, PT-27 PT-22P, PT-22 PT-22GS, PT-22H	DX-A41, Autofast
Clip with 2" Pin	PHBC-200	100	1,000		
Clip with 2 1/2" Pin	PHBC-250	50	1,000		



PHBC

Pre-Assembled BX Cable Straps and Conduit Straps – .300" Headed Fasteners with .145" Shank Diameter

Description	Model	Pack Qty.	Carton Qty.	Compatible Tools	
				Simpson Strong-Tie	Others
BX Cable Strap with 1" Pin	PBXDP-100	100	1,000	PTP-27L PTP-27S PT-27 PT-22P PT-22 PT-22GS PT-22H	D-60, 721, System 1, System 3, DX-350 and most other tools.
BX Cable Strap with 1 1/4" Pin	PBXDP-125	100	1,000		
Conduit Clip 1/2" EMT with 1" Pin	PCC50-DP100	100	1,000		
Conduit Clip 1/2" EMT with 1 1/4" Pin	PCC50-DP125	100	1,000		
Conduit Clip 3/4" EMT with 1" Pin	PCC75-DP100	50	500		
Conduit Clip 3/4" EMT with 1 1/4" Pin	PCC75-DP125	50	1,000		
Conduit Clip 1" EMT with 1" Pin	PCC100-DP100	50	500		
Conduit Clip 1" EMT with 1 1/4" Pin	PCC100-DP125	50	500		



PBXDP

PCC

Pre-Assembled Ceiling Clips – .300" Headed Fasteners with .145" Shank Diameter

Description	Model	Pack Qty.	Carton Qty.	Compatible Tools	
				Simpson Strong-Tie	Others
Compact Ceiling Clip - No Pin	PCL	100	1,000	PTP-27L PTP-27S PT-27 PT-22P PT-22 PT-22GS PT-22H	DX-350, System 1, 721 and most other tools.
Compact Ceiling Clip with 1" Pin	PECLDP-100	100	1,000		
Compact Ceiling Clip with 1" Pin - BULK PACK	PECLDP-100M	-	1,000		
Compact Ceiling Clip with 1 1/4" Pin	PECLDP-125	100	1,000		
Compact Ceiling Clip with 1 1/4" Pin - BULK PACK	PECLDP-125M	-	1,000		
Ceiling Clip with 1" Pin	PCLDP-100	100	1,000		
Ceiling Clip with 1 1/4" Pin	PCLDP-125	100	1,000		

See pages 210 and 212 for load value information.



PCLDP (PCL similar without pin)

See page 212 for load value information.



PECLDP

3/8" Headed Fasteners* with .177" Shank Diameter

Length (in.)	Model	Pack Qty.	Carton Qty.	Compatible Tools	
				Simpson Strong-Tie	Others
3/4 Knurled	PHV3-75K	100	1,000	PTP-27L PTP-27S PT-27 PT-22P PT-27HD PT-22 PT-22GS PT-22H	DX-451, DX-600, MD-380, DX-A41 I, R6000 and most other 3/8" barrel tools.
1	PHV3-100	100	1,000		
1 1/4	PHV3-125	100	1,000		
1 1/2	PHV3-150	100	1,000		
2	PHV3-200	100	1,000		
2 Knurled	PHV3-200K	100	1,000		
2 1/2	PHV3-250	100	1,000		
3	PHV3-300	100	1,000		



PHV3

*Not intended for use in high-velocity tools.

For alternate overhead fastening, see the Tie Wire wedge anchor on page 133 or Tie Wire Crimp anchor on page 168.

Fasteners For Simpson Strong-Tie® Powder-Actuated Tools

¼" – 20 Threaded Studs*

Length (in.)	Model	Pack Qty.	Carton Qty.	Compatible Tools	
				Simpson Strong-Tie	Others
¼ - 20 Knurled (T-½, S-½)	PSLV4-5050K	100	1,000	PTP-27L PTP-27S PT-27 PT-22P PT-22 PT-22GS PT-22H	Most L.V. piston tools.
¼ - 20 (T-½, S-¾)	PSLV4-5075	100	1,000		
¼ - 20 (T-½, S-1)	PSLV4-50100	100	1,000		
¼ - 20 (T-½, S-1¼)	PSLV4-50125	100	1,000		
¼ - 20 (T-¾, S-¾)	PSLV4-7575	100	1,000		
¼ - 20 Knurled (T-¾, S-½)	PSLV4-7550K	100	1,000		
¼ - 20 (T-¾, S-1)	PSLV4-75100	100	1,000		
¼ - 20 (T-¾, S-1¼)	PSLV4-75125	100	1,000		
¼ - 20 (T-1, S-1)	PSLV4-100100	100	1,000		
¼ - 20 Knurled (T-1¼, S-½)	PSLV4-12550K	100	1,000		
¼ - 20 (T-1¼, S-1¼)	PSLV4-125125	100	1,000		

*Shank diameter is .150". NOTE: T = Thread Length, S = Shank Length.

See pages 211 and 214 for load value information.



PSLV4

¾" – 16 Threaded Studs* (Factory Mutual Listing-see below)

Length (in.)	Model	Pack Qty.	Carton Qty.	Compatible Tools	
				Simpson Strong-Tie	Others
¾ - 16 Knurled (T-1¼, S-¾)	PSLV3-12575K	100	1,000	PT-27HD	Most other ¾" Barrel tools.
¾ - 16 (T-1¼, S-1)	PSLV3-125100	100	1,000		
¾ - 16 (T-1¼, S-1¼)	PSLV3-125125**	100	1,000		

*Shank diameter is .205". NOTE: T = Thread Length, S = Shank Length.

**Factory Mutual Listing 3031724

See pages 210, 211 and 214 for load value information.



PSLV3

Gas and Powder-Actuated Fastening Systems

Metric Fasteners

8MM Headed Fasteners with 3.68MM Shank Diameter

Length (in.)	Model	Pack Qty.	Carton Qty.	Compatible Tools	
				Simpson Strong-Tie	Others
½ Knurled	PHN-14K	100	1,000	PTP-27L* PTP-27S** PT-27 PT-22P PT-22 PT-22GS PT-22H	DX-350, DX-36, DX-400E, DX-A40, DX-460, DX-A41, System 1, DX-351 and 8mm tools.
⅝ Knurled	PHN-16K	100	1,000		
¾ Knurled	PHN-19K	100	1,000		
7⁄8	PHN-22	100	1,000		
1	PHN-27	100	1,000		
1¼	PHN-32	100	1,000		
1½	PHN-37	100	1,000		
1⅝	PHN-42	100	1,000		
1⅞	PHN-47	100	1,000		
2	PHN-52	100	1,000		
2¼	PHN-57	100	1,000		
2½	PHN-62	100	1,000		
2⅞	PHN-72	100	1,000		

*Up to 2½"

**Up to 1½"

See pages 209, 210 and 214 for load value information.



PHN

Fasteners For Simpson Strong-Tie® Powder-Actuated Tools

Metric Fasteners (Cont'd)

8MM Headed Fasteners with 3.68MM Shank Diameter and 1" Metal Washers

Length (in.)	Model	Pack Qty.	Carton Qty.	Compatible Tools	
				Simpson Strong-Tie	Others
1	PHNW-27	100	1,000	PTP-27L PTP-27S* PT-27 PT-22P PT-22 PT-22GS PT-22H	DX-350, DX-36, DX-400E, DX-A40, DX-A41, DX-460, System1, DX-351 and 8mm tools.
1¼	PHNW-32	100	1,000		
1½	PHNW-37	100	1,000		
1¾	PHNW-42	100	1,000		
1⅞	PHNW-47	100	1,000		
2	PHNW-52	100	1,000		
2¼	PHNW-57	100	1,000		
2½	PHNW-62	100	1,000		
2⅞	PHNW-72	100	1,000		

*Up to 2"

See pages 209 and 214 for load value information.



PHNW

6MM Headed Fasteners with 3.68MM Shank Diameter and 12MM Washers

Length (in.)	Model	Pack Qty.	Carton Qty.	Compatible Tools
7/8	PHK-22	100	1,000	DX-100L, DX-300, DX-400B, DX-450, DX-460, DX-451 and 12mm tools
1	PHK-27	100	1,000	
1¼	PHK-32	100	1,000	
1½	PHK-37	100	1,000	
1¾	PHK-42	100	1,000	
2	PHK-52	100	1,000	
2½	PHK-62	100	1,000	
2⅞	PHK-72	100	1,000	



PHK

8MM Headed Tophat Fasteners with 3.68MM Shank Diameter

Length (in.)	Model	Pack Qty.	Carton Qty.	Compatible Tools	
				Simpson Strong-Tie	Others
5/8 Knurled	PHNT-16K	100	1,000	PTP-27L, PTP-27S PT-27, PT-22P, PT-22 PT-22GS, PT-22H	DX-35, DX-351, and most 8mm tools
3/4 Knurled	PHNT-19K	100	1,000		
7/8	PHNT-22	100	1,000		
1	PHNT-27	100	1,000		

See pages 212-214 for load value information.



PHNT

Fasteners For Simpson Strong-Tie® Powder-Actuated Tools

Metric Fasteners (Cont'd)

Collated Fasteners - 8mm Headed with 3.68 MM Shank Diameter

Length (in.)	Model	Pack Qty.	Carton Qty.	Compatible Tools	
				Simpson Strong-Tie	Others
1/2 Knurled	PHSNA-14K	100	1,000	PTP-27SMAGR (through 32mm) PTP-27LMAGR (through 72mm)	DX-A40 with magazine, DX-A41 with magazine, DX-351, DX-460 with magazine
5/8 Knurled	PHSNA-16K	100	1,000		
3/4	PHSNA-19	100	1,000		
3/4 Knurled	PHSNA-19K	100	1,000		
7/8	PHSNA-22	100	1,000		
1	PHSNA-27	100	1,000		
1 1/4	PHSNA-32	100	1,000		
1 1/2	PHSNA-37	100	1,000		
1 5/8	PHSNA-42	100	1,000		
1 7/8	PHSNA-47	100	1,000		
2	PHSNA-52	100	1,000		
2 1/4	PHSNA-57	100	1,000		
2 1/2	PHSNA-62	100	1,000		
2 7/8	PHSNA-72	100	1,000		

See pages 209 and 214 for load value information.

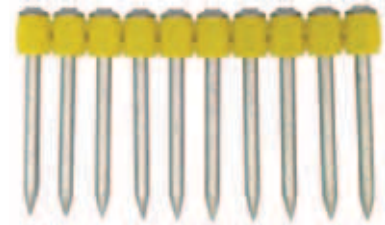

PHSNA

Threaded Rod Hangers - 8mm Headed with 3.68 MM Shank Diameter

Length (in.)	Model	Pack Qty.	Carton Qty.	Compatible Tools	
				Simpson Strong-Tie	Others
1 1/4, 1/4 - 20 Threaded Rod Hanger	PTRH4-HN32	50	500	PTP-27L, PTP-27S PT-27, PT-22P PT-22 PT-22GS, PT-22H	DX-351, DX-350, DX-36, DX-35, DX-A40
1 1/4, 3/8 - 16 Threaded Rod Hanger	PTRH3-HN32	50	500		

See pages 210 and 212 for load value information.

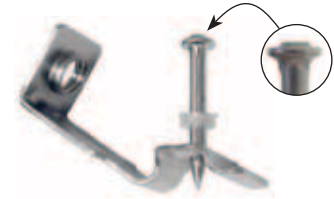

PTRH3

Concrete Forming Pin - .187" Headed with .145" Shank Diameter

Length (in.)	Model	Pack Qty.	Carton Qty.	Compatible Tools	
				Simpson Strong-Tie	Others
3/16 x 2 1/2 Concrete Forming Pin	PKP-250	100	1,000	PTP-27L, PT-27 PT-22, PT-22GS PT-22H	DX-Series and 8mm tools



PKP

NOTE: Lengths in inches are for reference only and may not be exact.

Fasteners For Simpson Strong-Tie® Powder-Actuated Tools

Miscellaneous

Manual Hammer
Tool (not for use with
powder loads)

¼" Headed Hammer Drive Fastener with ¾" Metal Washer

Length (in.)	Model	Pack Qty.	Carton Qty.	Compatible Tools	
				Simpson Strong-Tie	Others
½	PHD-50	100	1,000	PHT-38	HT-38, R-260, R-375, XL-143, and other hammer drive tools
¾	PHD-75	100	1,000		
1	PHD-100	100	1,000		
1¼	PHD-125	100	1,000		
1½	PHD-150	100	1,000		
2	PHD-200	100	1,000		
2½	PHD-250	100	1,000		
3	PHD-300	100	1,000		



PHD



PHT-38



Warning: Do not use powder loads with this tool. This is a hammer drive tool only. Use of powder loads with this tool may result in injury or death.

Powder-Actuated Tool Repair and Maintenance Kits

Tool	Kit Model No.	Description	Contents
PT-27	PT-27PK1	Normal wear part replacement kit	5 Shear Clips (Part No. PT-301011)
			1 Annular Spring (Part No. PT-301014)
			1 Piston Stop (Part No. PT-301012)
			3 Ball Bearings (Part No. PT-301013)
			1 Piston (Part No. PT-301903)
			2 Piston Rings (Part No. PT-301208)
			1 Nosepiece (Part No. PT-301010)
All	PT-MK1	Tool cleaning kit	1 Cleaning Brush - Wire (Part No. BRUSH 125)
			1 Cleaning Brush ¾" Diameter (Part No. BRUSH 25)
			1 Cleaning Brush ¼" Diameter (Part No. BRUSH 75)
			1 PAT Tool Lubricant - 4 oz. spray bottle (Part No. PT-MTL4.0)
			(1) ½" Hex Wrench (Part No. MW-18)
			(1) ¾" Hex Wrench (Part No. MW-316)
All	PT-MTL2.0	Tool lubricant	(1) 5mm Hex Wrench (Part No. MW-5)
			4 oz. spray bottle

Tension & Shear Load Values For Simpson Strong-Tie® Fasteners

Code Reports: Reference ICC-ES ESR-2138, Florida FL 11506.3 and City of L.A. RR25469 for code-listed fasteners and applications

PDPA Tension and Shear Loads in Steel

 * See page 13 for an explanation of the load table icons

Model No.	Shank Diameter in. (mm)	Minimum Penetration in. (mm)	Minimum Edge Distance in. (mm)	Minimum Spacing in. (mm)	Minimum Steel Strength ³	Allowable Tension Loads – lbs. (kN)					Allowable Shear Loads – lbs. (kN)				
						Steel Thickness (in.)					Steel Thickness (in.)				
						3/16	1/4	3/8	1/2	3/4	3/16	1/4	3/8	1/2	3/4
PDPA	0.157 (4.0)	THRU ¹	0.5 (13)	1.0 (25)	ASTM A36	260 (1.16)	370 (1.65)	380 ⁷ (1.69) ⁷	530 ⁷ (2.36) ⁷	195 ⁴ (0.87) ⁴	410 (1.82)	365 (1.62)	385 ⁷ (1.71) ⁷	385 ⁷ (1.71) ⁷	325 ⁴ (1.45) ⁴
		THRU ¹	0.5 (13)	1.0 (25)	ASTM A572, Grade 50 or ASTM A992	305 (1.36)	335 (1.49)	355 ⁷ (1.58) ⁷	485 ⁵ (2.16) ⁵	170 ⁶ (0.76) ⁶	420 (1.87)	365 (1.62)	290 ⁷ (1.29) ⁷	275 ⁵ (1.22) ⁵	275 ⁶ (1.22) ⁶

- The entire pointed portion of the fastener must penetrate through the steel to obtain the tabulated values, unless otherwise indicated in footnote 4, 5, 6 or 7.
- The allowable tension and shear values are for the fastener only. Members connected to the steel must be investigated separately in accordance with accepted design criteria.
- Steel strength must comply with the minimum requirements of ASTM A 36 (Fy = 36 ksi, Fu = 58 ksi) or ASTM A 572, Grade 50 (Fy = 50 ksi, Fu = 65 ksi), or ASTM A992 (Fy = 50 ksi, Fu = 65 ksi)
- Based upon minimum penetration depth of 0.46" (11.7 mm).
- Based upon minimum penetration depth of 0.58" (14.7 mm).
- Based upon minimum penetration depth of 0.36" (9.1 mm).
- The fastener must be driven to where the point of the fastener penetrates through the steel.



Gas and Powder-Actuated Fastening Systems

PDPA Tension and Shear Loads in Normal-Weight Concrete

 * See page 13 for an explanation of the load table icons

Model No.	Shank Diameter in. (mm)	Minimum Penetration in. (mm)	Minimum Edge Distance in. (mm)	Minimum Spacing in. (mm)	Allowable Tension Load lbs. (kN)		Allowable Shear Load lbs. (kN)	
					f'c ≥ 4,000 psi (27.6 MPa) Concrete	f'c ≥ 6,000 psi (41.3 MPa) Concrete	f'c ≥ 4,000 psi (27.6 MPa) Concrete	f'c ≥ 6,000 psi (41.3 MPa) Concrete
					PDPA	0.157 (4.0)	3/4 (19)	3.5 (89)
1 (25)	3.5 (89)	5 (127)	310 (1.38)	160 (0.71)			310 (1.38)	350 (1.56)
1 1/4 (32)	3.5 (89)	5 (127)	380 (1.69)	365 (1.62)			420 (1.87)	390 (1.73)

- The fastener shall not be driven until the concrete has reached the designated compressive strength. Minimum concrete thickness is three times the fastener embedment into the concrete.
- The allowable tension and shear values are for the fastener only. Members connected to the steel must be investigated separately in accordance with accepted design criteria.

PDPA Tension and Shear Loads in Lightweight Concrete over Metal Deck

 * See page 13 for an explanation of the load table icons

Model No.	Shank Diameter in. (mm)	Minimum Penetration in. (mm)	Allowable Tension Load - lbs. (kN)		Allowable Shear Load - lbs. (kN)	
			Installed In Concrete	Installed Thru. Metal Deck	Installed In Concrete	Installed Thru. Metal Deck
			f'c ≥ 3,000 psi (20.7 MPa) Concrete		f'c ≥ 3,000 psi (20.7 MPa) Concrete	
PDPA	0.157 (4.0)	3/4 (19)	85 (0.38)	105 (0.47)	105 (0.47)	280 (1.25)
		1 (25)	150 (0.67)	145 (0.64)	225 (1.00)	280 (1.25)
		1 1/4 (32)	320 (1.42)	170 (0.76)	420 (1.87)	320 (1.42)

- The fastener shall not be driven until the concrete has reached the designated compressive strength. Minimum concrete thickness is three times the fastener embedment into the concrete.
- The allowable tension and shear values are for the fastener only. Members connected to the steel must be investigated separately in accordance with accepted design criteria.
- Metal deck must be minimum 20 gauge and has a minimum yield strength of 38,000 psi.
- Shear values are for loads applied toward edge of flute.
- The fastener shall be installed 1 1/2" from the edge of flute.

Tension & Shear Load Values For Simpson Strong-Tie® Fasteners

PDP Series Fasteners - Tension and Shear Loads in Normal-Weight Concrete



Model No.	Shank Diameter inches (mm)	Minimum Penetration inches (mm)	Minimum Edge Distance inches (mm)	Minimum Spacing inches (mm)	Allowable Tension Load ² - lbs. (kN)			Allowable Shear Load ² - lbs. (kN)		
					f' _c ≥ 2000 psi (13.8 MPa) Concrete	f' _c ≥ 3000 psi (20.7 MPa) Concrete	f' _c ≥ 4000 psi (27.6 MPa) Concrete	f' _c ≥ 2000 psi (13.8 MPa) Concrete	f' _c ≥ 3000 psi (20.7 MPa) Concrete	f' _c ≥ 4000 psi (27.6 MPa) Concrete
PDP	0.145 (3.7)	1 (25)	3 (75)	4 (100)	45 (0.2)	100 (0.44)	150 (0.67)	120 (0.53)	165 (0.73)	205 (0.91)
	0.145 (3.7)	1¼ (32)	3 (75)	4 (100)	140 (0.62)	255 (1.13)	370 (1.65)	265 (1.18)	265 (1.18)	265 (1.18)
PDP-SS	0.145 (3.7)	1 (25)	3 (75)	4 (100)	60 (0.27)	•	•	195 (0.87)	•	•

- The fasteners shall not be driven until the concrete has reached the designated compressive strength. Minimum concrete thickness is three times the fastener embedment into the concrete.
- The allowable tension and shear values are for the fastener only. Wood or steel members connected must be investigated in accordance with accepted design criteria.

The table applies to the following Simpson Strong-Tie fasteners where minimum penetration exists:

*See page 13 for an explanation of the load table icons

PDP*	PDPW*	PDPWL*
PDP-125	PDPW-125	PDPWL-125
PDP-150	PDPW-150	PDPWL-150
PDP-175	PDPW-175	PDPWL-175
PDP-200	PDPW-200	PDPWL-200
PDP-225	PDPW-225	PDPWL-225
PDP-250	PDPW-250	PDPWL-250
PDP-300	PDPW-300	PDPWL-300
		PDPWL-400

*Including stainless steel models.



PDP & PDP-SS

PDPW

PDPWL & PDPWL-SS

For more information on these fasteners go to pages 201 and 202.

PHN Series Fasteners - Tension and Shear Loads in Normal-Weight Concrete



Model No.	Shank Diameter inches (mm)	Minimum Penetration inches (mm)	Minimum Edge Distance inches (mm)	Minimum Spacing inches (mm)	Allowable Tension Load ² - lbs. (kN)			Allowable Shear Load ² - lbs. (kN)		
					f' _c ≥ 2000 psi (13.8 MPa) Concrete	f' _c ≥ 3000 psi (20.7 MPa) Concrete	f' _c ≥ 4000 psi (27.6 MPa) Concrete	f' _c ≥ 2000 psi (13.8 MPa) Concrete	f' _c ≥ 3000 psi (20.7 MPa) Concrete	f' _c ≥ 4000 psi (27.6 MPa) Concrete
PHN	0.145 (3.7)	1 (25)	3 (75)	4 (100)	45 (0.2)	100 (0.44)	150 (0.67)	120 (0.53)	165 (0.73)	205 (0.91)
	0.145 (3.7)	1¼ (32)	3 (75)	4 (100)	140 (0.62)	255 (1.13)	370 (1.65)	265 (1.18)	265 (1.18)	265 (1.18)

- The fasteners shall not be driven until the concrete has reached the designated compressive strength. Minimum concrete thickness is three times the fastener embedment into the concrete.
- The allowable tension and shear values are for the fastener only. Wood or steel members connected must be investigated in accordance with accepted design criteria.

The table applies to the following Simpson Strong-Tie® fasteners where minimum penetration exists:

PHN	PHNW	PHSNA
PHN-27	PHNW-27	PHSNA-27
PHN-32	PHNW-32	PHSNA-32
PHN-37	PHNW-37	PHSNA-37
PHN-42	PHNW-42	PHSNA-42
PHN-47	PHNW-47	PHSNA-47
PHN-52	PHNW-52	PHSNA-52
PHN-57	PHNW-57	PHSNA-57
PHN-62	PHNW-62	PHSNA-62
PHN-72	PHNW-72	PHSNA-72



PHN



PHNW

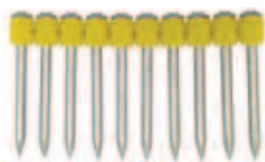

PHSNA

For more information on these fasteners go to pages 204, 205 and 206.

Spacing of PDP and PHN Fasteners for Attachment of Wood Sill Plates to Normal-Weight Concrete

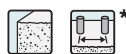

Model No.	Overall Length inches (mm)	Head Diameter inches (mm)	Shank Diameter inches (mm)	Maximum Spacing inches (mm)		
				Interior Shear Walls ³	Interior Nonshear Walls ²	Exterior Shear Walls ³
PDPW-300 PDPWL-300 PDPWL-300MG PDPWLS-300MG	3 (76)	5/16 (7.9)	0.145 (3.7)	12 (305)	24 (610)	12 (305)
PHN-72 or PHNW-72	2 7/8 (73)	5/16 (7.9)	0.145 (3.7)	18 (457)	36 (914)	18 (457)

- Spacings are based upon the attachment of 2-inch (nominal thickness) wood sill plates, with specific gravity of 0.50 or greater, to concrete floor slabs or footings. For species of wood with specific gravity of 0.42 to 0.49, multiply required spacing of fasteners for shear walls by 0.81. For species of wood with specific gravity of 0.31 to 0.41, multiply the required spacing of fasteners for shear walls by 0.65.
- All walls shall have fasteners placed at 6 inches from ends of sill plates, with maximum spacing as shown in the table.
- Fasteners indicated shall have two pins placed 6 inches and 10 inches, respectively, from each end of sill plates, with maximum spacing as shown in the table.
- All fasteners must be installed with a minimum 3/4-inch-diameter, No. 16 gauge (0.0598 inch) steel washer.
- Fasteners shall not be driven until the concrete has reached a compressive strength of 2,000 psi. Minimum edge distance is 1¼ inches.
- The fasteners shall not be used for the attachment of shear walls having a unit shear in excess of 100 pounds per foot. Spacings shown are independent of the number of building stories.

Tension & Shear Load Values For Simpson Strong-Tie® Fasteners

PDPH Series Fasteners - Tension and Shear Loads in Normal Weight Concrete



Model No.	Shank Diameter inches (mm)	Minimum Penetration inches (mm)	Minimum Edge Distance inches (mm)	Minimum Spacing inches (mm)	Allowable Tension Load - lbs. (kN)			Allowable Shear Load - lbs. (kN)		
					f' _c ≥ 2000 psi (13.8 MPa) Concrete	f' _c ≥ 4000 psi (27.6 MPa) Concrete	f' _c ≥ 6000 psi (41.4 MPa) Concrete	f' _c ≥ 2000 psi (13.8 MPa) Concrete	f' _c ≥ 4000 psi (27.6 MPa) Concrete	f' _c ≥ 6000 psi (41.4 MPa) Concrete
PDPH	0.177 (4.5)	¾ (19)	3½ (89)	5½ (130)	30 (0.13)	30 (0.13)	110 (0.29)	50 (0.22)	110 (0.49)	190 (0.84)
		1¼ (32)	3½ (89)	5½ (130)	130 (0.58)	260 (1.15)	190 (0.84)	265 (1.18)	220 (0.98)	105 (0.47)



PDPH

- The fasteners shall not be driven until the concrete has reached the designated compressive strength. Minimum concrete thickness is three times the fastener embedment into the concrete.
- The allowable tension values are for the fastener only. Connected members must be investigated separately in accordance with accepted design criteria.

* See page 13 for an explanation of the load table icons

For more information on these fasteners go to page 201.

PDP and PHN Fasteners Attaching Light Gauge Steel Channels - Shear Loads in Normal Weight Concrete



Model No.	Shank Diameter inches (mm)	Minimum Penetration inches (mm)	Light Gauge Steel Channel Thickness gauge	Allowable Shear Load lbs. (kN)
				f' _c ≥ 2000 psi (13.8 MPa) Concrete
PDP	0.145 (3.7)	¾ (22)	20	160 (0.71)
PHN	0.145 (3.7)	¾ (22)	20	160 (0.71)
PDP	0.145 (3.7)	¾ (22)	18	135 (0.60)
PHN	0.145 (3.7)	¾ (22)	18	135 (0.60)

- The fasteners shall not be driven until the concrete has reached the designated compressive strength. Minimum concrete thickness is three times the faster embedment into the concrete.

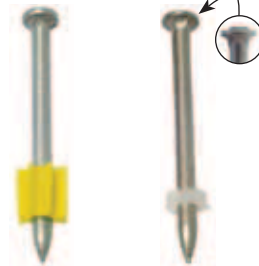

PDP

PHN

For more information on these fasteners go to pages 201 and 204.

PSLV Series Threaded Studs - Tension Loads in Normal Weight Concrete



Model No.	Shank Diameter inches (mm)	Minimum Penetration inches (mm)	Allowable Tension Load lbs. (kN)
			f' _c ≥ 2500 psi (17.2 MPa) Concrete
PSLV3	0.205 (5.2)	1¼ (32)	260 (1.16)

See notes below.



PSLV3

For more information on these fasteners go to page 204.

PTRH Series Rod Hangers - Tension Loads in Normal Weight Concrete

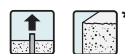

Model No.	Shank Diameter inches (mm)	Minimum Penetration inches (mm)	Allowable Tension Load lbs. (kN)
			f' _c ≥ 2500 psi (17.2 MPa) Concrete
PTRH3-HN32	0.145 (3.7)	1 (25)	150 (0.67)
PTRH4-HN32	0.145 (3.7)	1 (25)	150 (0.67)

- The fasteners shall not be driven until the concrete has reached the designated compressive strength. Minimum concrete thickness is three times the fastener embedment into the concrete.
- The allowable tension values are for the fastener only. Connected members must be investigated separately in accordance with accepted design criteria.

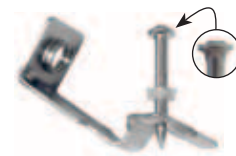

PTRH3

For more information on these fasteners go to page 206.

PCLDP Series Ceiling Clips - Tension Loads in Normal Weight Concrete



Model No.	Shank Diameter inches (mm)	Minimum Penetration inches (mm)	Allowable Tension Load lbs. (kN)
			f' _c ≥ 2000 psi (13.8 MPa) Concrete
PCLDP-125	0.145 (3.7)	1¼ (29)	25 (0.11)

- The fasteners shall not be driven until the concrete has reached the designated compressive strength. Minimum concrete thickness is three times the faster embedment into the concrete.



PCLDP

For more information on these fasteners go to page 203.

Tension & Shear Load Values For Simpson Strong-Tie® Fasteners

PDPT Series Fasteners - Tension Loads in Lightweight Concrete over Metal Deck

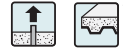

Model No.	Shank Diameter inches (mm)	Minimum Penetration inches (mm)	Allowable Tension Load, lbs. (kN) (Installed in Concrete)	Allowable Tension Load, lbs. (kN) (Installed through Metal Deck)
			$f'_c \geq 3000$ psi (20.7 MPa) Concrete	$f'_c \geq 3000$ psi (20.7 MPa) Concrete
PDPT	0.145 (3.7)	7/8 (22)	90 (0.40)	40 (0.18)

See notes 1-5 below.

PDPT Series Fasteners - Shear Loads in Lightweight Concrete over Metal Deck



Model No.	Shank Diameter inches (mm)	Minimum Penetration inches (mm)	Allowable Shear Load, lbs. (kN) (Installed in Concrete)	Allowable Shear Load, lbs. (kN) (Installed through Metal Deck)
			$f'_c \geq 3000$ psi (20.7 MPa) Concrete	$f'_c \geq 3000$ psi (20.7 MPa) Concrete
PDPT	0.145 (3.7)	7/8 (22)	250 (1.11)	280 (1.24)

1. The fasteners shall not be driven until the concrete has reached the designated compressive strength. Minimum concrete thickness is three times the fastener embedment into the concrete.
2. The allowable tension and shear values are for the fastener only. Connected members must be investigated separately in accordance with accepted design criteria.
3. Metal deck must be minimum 20 gauge.
4. Shear values are for loads applied toward edge of flute.
5. The fasteners shall be installed 1 1/2 inch from the edge of flute.



PDPT

For more information on these fasteners go to page 203.

Tension Loads for 1/4" - 20 Threaded Studs in Lightweight Concrete Over a Metal Deck



Model No.	Shank Diameter inches (mm)	Minimum Penetration inches (mm)	Allowable Tension Load, lbs. (kN) (Installed through Metal Deck)
			$f'_c \geq 3000$ psi (20.7 MPa) Concrete
PSLV4	0.150 (3.8)	1 (25)	80 (0.36)

*See page 13 for an explanation of the load table icons

1. The fasteners shall not be driven until the concrete has reached the designated compressive strength. Minimum concrete thickness is three times the fastener embedment into the concrete.
2. The allowable tension values are for the fastener only. Connected members must be investigated separately in accordance with accepted design criteria.
3. Metal deck must be minimum 20 gauge.
4. The fasteners shall be installed 1 1/2 inch from the edge of flute.



PSLV4

For more information on these fasteners go to page 204.

Tension Loads for 3/8" - 16 Threaded Studs in Lightweight Concrete over Metal Deck



Model No.	Shank Diameter inches (mm)	Minimum Penetration inches (mm)	Allowable Tension Load, lbs. (kN) (Installed through Metal Deck)
			$f'_c \geq 3000$ psi (20.7 MPa) Concrete
PSLV3	0.205 (5.21)	1 1/4 (32)	225 (1.00)

1. The fasteners shall not be driven until the concrete has reached the designated compressive strength. Minimum concrete thickness is three times the fastener embedment into the concrete.
2. The allowable tension values are for the fastener only. Connected members must be investigated separately in accordance with accepted design criteria.
3. Metal deck must be minimum 20 gauge.
4. The fasteners shall be installed 1 1/2 inch from the edge of flute.



PSLV3

For more information on these fasteners go to page 204.

Tension & Shear Load Values For Simpson Strong-Tie® Fasteners

PCL & PECL Series Ceiling Clips - Tension and Oblique Loads in Sand-Lightweight Concrete over Metal Deck



Model No.	Shank Diameter inches (mm)	Minimum Penetration inches (mm)	Allowable Tension Load, lbs. (kN) (Installed through Metal Deck)	
			f'c ≥ 3000 psi (20.7 MPa) Concrete	f'c ≥ 3000 psi (20.7 MPa) Concrete
PCLDP-100	0.145 (3.7)	7/8 (22)	55 (0.24)	85 (0.38)
PECLDP-125	0.145 (3.7)	1 (25)	55 (0.24)	85 (0.38)
PCLDP-125	0.145 (3.7)	1 (25)	55 (0.24)	85 (0.38)
PECLHN-27	0.145 (3.7)	1 (25)	55 (0.24)	85 (0.38)
PCLHN-27	0.145 (3.7)	1 (25)	55 (0.24)	85 (0.38)

1. The fasteners shall not be driven until the concrete has reached the designated compressive strength. Minimum concrete thickness is three times the fastener embedment into the concrete.
2. The allowable tension and shear values are for the fastener only. Connected members must be investigated separately in accordance with accepted design criteria.
3. Metal deck must be minimum 20 gauge.
4. Oblique values are for loads applied toward edge of flute.
5. The fasteners shall be installed 1 1/2 inch from the edge of flute.

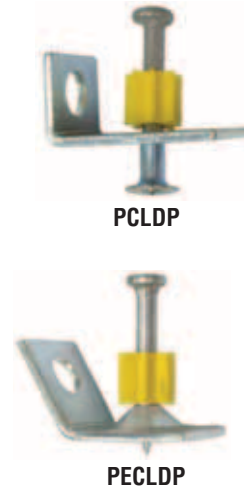

For more information on these fasteners go to page 203.

Gas and Powder-Actuated Fastening Systems

PTRH Series Threaded Rod Hangers - Tension Loads in Sand-Lightweight Concrete over Metal Deck



Model No.	Shank Diameter inches (mm)	Minimum Penetration inches (mm)	Allowable Tension Load, lbs. (kN) (Installed through Metal Deck)	
			f'c ≥ 3000 psi (20.7 MPa) Concrete	f'c ≥ 3000 psi (20.7 MPa) Concrete
PTRH3-HN32	0.145 (3.7)	1 (25)	140 (0.62)	140 (0.62)
PTRH4-HN32	0.145 (3.7)	1 (25)	140 (0.62)	140 (0.62)

*See page 13 for an explanation of the load table icons

1. The fasteners shall not be driven until the concrete has reached the designated compressive strength. Minimum concrete thickness is three times the fastener embedment into the concrete.
2. The allowable tension values are for the fastener only. Connected members must be investigated separately in accordance with accepted design criteria.
3. Metal deck must be minimum 20 gauge.
4. The fasteners shall be installed 1 1/2 inch from the edge of flute.



For more information on these fasteners go to page 206.

PHNT Series Fasteners - Tension Loads in Sand-Lightweight Concrete Over Metal Deck



Model No.	Shank Diameter inches (mm)	Minimum Penetration inches (mm)	Allowable Tension Load, lbs. (kN) (Installed through Metal Deck)	
			f'c ≥ 3000 psi (20.7 MPa) Concrete	f'c ≥ 3000 psi (20.7 MPa) Concrete
PHNT	0.145 (3.7)	7/8 (22)	185 (0.82)	165 (0.73)

See notes 1-5 below.

PHNT Series Fasteners - Shear Loads in Sand-Lightweight Concrete Over Metal Deck



Model No.	Shank Diameter inches (mm)	Minimum Penetration inches (mm)	Allowable Shear Load, lbs. (kN) (Installed through Metal Deck)	
			f'c ≥ 3000 psi (20.7 MPa) Concrete	f'c ≥ 3000 psi (20.7 MPa) Concrete
PHNT	0.145 (3.7)	7/8 (22)	275 (1.22)	400 (1.78)

1. The fasteners shall not be driven until the concrete has reached the designated compressive strength. Minimum concrete thickness is three times the fastener embedment into the concrete.
2. The allowable tension and shear values are for the fastener only. Connected members must be investigated separately in accordance with accepted design criteria.
3. Metal deck must be minimum 20 gauge.
4. Shear values are for loads applied toward edge of flute.
5. The fasteners shall be installed 1 1/2 inch from the edge of flute.



For more information on these fasteners go to page 205.

Tension & Shear Load Values For Simpson Strong-Tie® Fasteners

PDP Tension and Shear Loads in Hollow CMU



Model No.	Shank Diameter inches (mm)	Minimum Penetration inches (mm)	Minimum Edge Distance inches (mm)	Minimum End Distance inches (mm)	Minimum Spacing inches (mm)	8-inch Hollow CMU Loads Based on CMU Strength	
						Tension Load	Shear Load
						Allowable lbs. (kN)	Allowable lbs. (kN)
PDP	0.145 (3.7)	1¼ (44)	4 (100)	4½ (116)	4 (100)	110 (0.50)	200 (0.90)

- Values for 8-inch wide CMU Grade N, Type II, lightweight, medium-weight and normal weight concrete masonry units conforming to UBC Standard 21-4 or ASTM C90.
- The embedment depth is measured from the outside face of the concrete masonry unit and is based on the anchor being embedded an additional ½ inch through 1¼" thick face shell.
- Allowable loads may not be increased for short-term loading due to wind or seismic forces. CMU wall design must satisfy applicable design standards and be capable of withstanding applied loads.



PDP

For more information on these fasteners go to page 201.

PDP Series Fasteners - Tension and Shear Loads in Steel



Model No.	Shank Diameter inches (mm)	Minimum Edge Distance inches (mm)	Minimum Spacing inches (mm)	Steel Thickness ³ inches (mm)	Allowable Tension Load ² lbs. (kN)	Allowable Shear Load ² lbs. (kN)
PDP	0.145 (3.7)	½ (12.7)	1 (25)	3/16 (4.8)	155 (0.69)	395 (1.76)
PDP Knurled	0.145 (3.7)	½ (12.7)	1 (25)	¼ (6.4)	210 (0.93)	-

See notes below.



PDP



PDPH

PDPH Series Fasteners - Tension and Shear Loads in Steel



Model No.	Shank Diameter inches (mm)	Minimum Edge Distance inches (mm)	Minimum Spacing inches (mm)	Steel Thickness ³ inches (mm)	Allowable Tension Load ² lbs. (kN)	Allowable Shear Load ² lbs. (kN)
PDPH	0.177 (4.5)	½ (13)	1 (25)	3/16 (5)	335 (1.49)	790 (3.51)
				¼ (6)	520 (2.31)	870 (3.87)

*See page 13 for an explanation of the load table icons

- The entire pointed portion of the fastener must penetrate through the steel to obtain the tabulated values. See Detail A.
- The allowable tension and shear values are for the fastener to steel only. Connected members must be investigated separately in accordance with accepted design criteria.
- Steel must conform to ASTM A36 specifications, with Fy = 36,000 psi, minimum.

The table applies to the following Simpson Strong-Tie fasteners where minimum penetration exists:

PDP	PDPW	PDPWL
PDP-50K	-	-
PDP-62K	-	-
PDP-100	PDPW-100	PDPWL-100
PDP-125	PDPW-125	PDPWL-125
PDP-150	PDPW-150	PDPWL-150
PDP-175	PDPW-175	PDPWL-175
PDP-200	PDPW-200	PDPWL-200
PDP-225	-	-
PDP-250	PDPW-250	PDPWL-250
PDP-300	PDPW-300	PDPWL-300

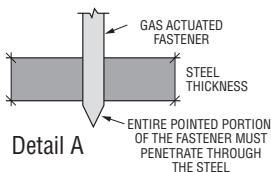

Detail A



PDPWL



PDPW

For more information on these fasteners go to page 202.

PDPT Series Fasteners - Tension and Shear Loads in Steel



Model No.	Shank Diameter inches (mm)	Minimum Edge Distance inches (mm)	Minimum Spacing inches (mm)	Steel Thickness ³ inches (mm)	Allowable Tension Load ² lbs. (kN)	Allowable Shear Load ² lbs. (kN)
PDPT	0.145 (3.7)	½ (13)	1 (25)	1/8 (3)	150 (0.67)	530 (2.36)
				3/16 (5)	290 (1.29)	660 (2.93)
				¼ (6)	340 (1.51)	700 (3.11)

- The entire pointed portion of the fastener must penetrate through the steel to obtain the tabulated value. See Detail A.
- The allowable tension and shear values are for the fastener to steel only. Connected member must be investigated separately in accordance with accepted design criteria.
- Steel must conform to ASTM A36 specifications, with Fy = 36,000 psi, minimum.



PDPT

For more information on these fasteners go to page 203.

Tension & Shear Load Values For Simpson Strong-Tie® Fasteners

PHN Series Fasteners - Tension and Shear Loads in Steel



Model No.	Shank Diameter inches (mm)	Minimum Edge Distance inches (mm)	Minimum Spacing inches (mm)	Steel Thickness ³ inches (mm)	Allowable Tension Load ² lbs. (kN)	Allowable Shear Load ² lbs. (kN)
PHN	0.145 (3.7)	1/2 (12.7)	1 (25)	3/16 (4.8)	155 (0.69)	395 (1.76)
PHN ⁴ Knurled	0.145 (3.7)	1/2 (12.7)	1 (25)	1/4 (6.4)	440 (2.0)	-

1. The entire pointed portion of the fastener must penetrate through the steel to obtain the tabulated values. See Detail A.
2. The allowable tension and shear values are for the fastener into steel only. Wood members connected must be investigated separately in accordance with accepted design criteria.
3. Steel must conform to ASTM A 36 specifications, with Fy = 36,000 psi, minimum.
4. PHN-16K or longer.

The table applies to the following Simpson Strong-Tie fasteners where minimum penetration exists:

PHN	PHNW	PHSNA
PHN-16K	-	PHSNA-16K
PHN-19K	-	PHSNA-19K
PHN-27	PHNW-27	PHSNA-27
PHN-32	PHNW-32	PHSNA-32
PHN-37	PHNW-37	PHSNA-37
PHN-42	PHNW-42	PHSNA-42
PHN-47	PHNW-47	PHSNA-47
PHN-52	PHNW-52	PHSNA-52
PHN-57	PHNW-57	PHSNA-57
PHN-62	PHNW-62	PHSNA-62
PHN-72	PHNW-72	PHSNA-72

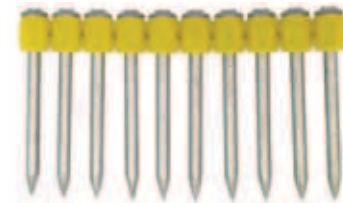
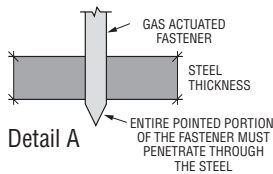

PHSNA

For more information on these fasteners go to pages 204, 205 and 206.

Gas and Powder-Actuated Fastening Systems

PHNT Series Fasteners - Tension and Shear Loads in Steel



Model No.	Shank Diameter inches (mm)	Minimum Edge Distance inches (mm)	Minimum Spacing inches (mm)	Steel Thickness ³ inches (mm)	Allowable Tension Load ² lbs. (kN)	Allowable Shear Load ² lbs. (kN)
PHNT	0.145 (3.7)	1/2 (13)	1 (25)	1/8 (3)	40 (0.18)	440 (1.96)
				3/16 (5)	50 (0.22)	620 (2.76)
				1/4 (6)	250 (1.11)	620 (2.76)

1. The entire pointed portion of the fastener must penetrate through the steel to obtain the tabulated value. See Detail A.
2. The allowable tension and shear values are for the fastener to steel only.
3. Steel must conform to ASTM A36 specifications, with Fy = 36,000 psi, minimum.

*See page 13 for an explanation of the load table icons



PHNT

For more information on these fasteners go to page 205.

PSLV Series Threaded Studs - Tension and Shear Loads in Steel



Model No.	Shank Diameter inches (mm)	Minimum Edge Distance inches (mm)	Minimum Spacing inches (mm)	Steel Thickness ³ inches (mm)	Allowable Tension Load ² lbs. (kN)	Allowable Shear Load ² lbs. (kN)
PSLV3	0.205 (5.2)	1 (25)	1 1/2 (41)	3/16 (5)	270 (1.20)	770 (3.42)
				1/4 (6)	680 (3.02)	1,120 (4.98)
PSLV4	0.150 (3.8)	1/2 (13)	1 (25)	3/16 (5)	200 (0.89)	630 (2.80)
				1/4 (6)	420 (1.87)	690 (3.07)

1. The entire pointed portion of the fastener must penetrate through the steel to obtain the tabulated value. See Detail A.
2. The allowable tension and shear values are for the fastener to steel only. Connected member must be investigated separately in accordance with accepted design criteria.
3. Steel must conform to ASTM A36 specifications, with Fy = 36,000 psi, minimum.



PSLV3



PSLV4

For more information on these fasteners go to page 204.

Carbide Drill Bits, Core Bits & Chisels

Simpson Strong-Tie offers a complete line of premium-quality drill bits, core bits and chisels to handle any drilling and demolition need. Our carbide products are manufactured to demanding tolerances and are designed to maximize production on the jobsite.



Carbide Drill Bits For Concrete and Masonry

Carbide Drill Bits

Our carbide-tipped drill bits are premium quality, professional-grade tools manufactured in Germany to the highest industry standards. They are designed to meet precise tolerance requirements and incorporate proprietary features that enhance durability, drilling speed and usability. Regular and quad head bit and solid-tipped tip configurations are available. Shank styles include SDS-Plus®, SDS-Max, Spline, and Straight.

FEATURES AND BENEFITS:

Uniformly-brazed carbide inserts result in longer bit life

- Most bits contain a centering tip that facilitates easy spot drilling
- Chromium-nickel-molybdenum steel alloy body ensures hammering quality and extended service life
- Heat-treatment procedures and shot peened finish increase surface hardness, drilling speed, reduces drill bit wear and improves resistance to bending forces
- Drill bits conform to ANSI Standard B212.15

ADDITIONAL ATTRIBUTES FOR SDS-MAX, SPLINE AND SELECT SDS-PLUS BITS:

Chisel-shaped drill bit head penetrates the material and directs concrete dust into the multi-flute spiral

- Patented, high-volume, multi-flute spiral quickly channels concrete dust from the hole to improve drilling speed
- Proprietary flute geometry reduces vibration and optimizes impact energy transfers from the rotary hammer into the drill bit tip which enhances drilling speed and durability and reduces noise, stress and vibration on the operator

QUAD HEAD FEATURE:

(Available in SDS-PLUS, SDS-MAX and Spline Shank)

All the features of single cutter bits plus Quad Head dual cutter design to improve durability and drilling speed. The high volume, double helix of Quad Head bit is produced with the patented, high-performance, reinforced core flute to maximize energy transfer.



Quad Head^{4x}

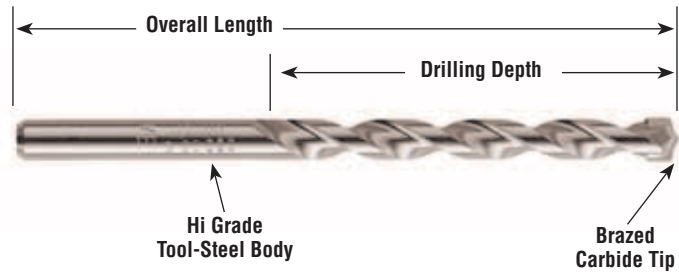

Simpson Strong-Tie® Drill Bits come in various shank styles to fit virtually any drill or rotohammer.

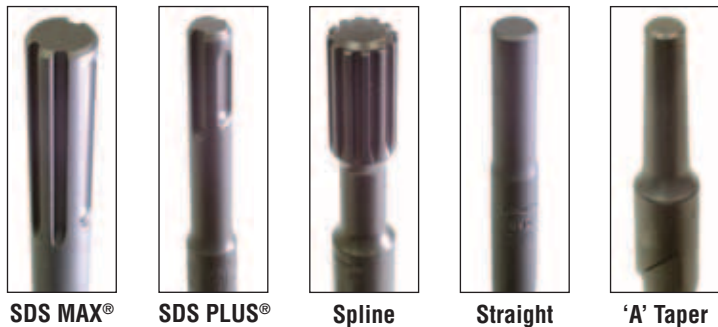

Drill Bit Tool Selection Guide

SDS-PLUS

Fits all current and older SDS PLUS rotohammers from AEG, Black & Decker, Bosch, DeWalt, Hitachi, Hilti, Kango, Makita, Metabo, Milwaukee, Porter Cable, Ramset, Red Head, Ryobi, Skil

SDS-MAX

Fits all current and older SDS MAX rotohammers from Black & Decker, Bosch, DeWalt, Hitachi, Hilti, Kango, Makita, Metabo, Milwaukee

Spline

Fits all current and older Spline rotohammers from AEG, Black & Decker, Bosch, DeWalt, Hitachi, Kango, Makita, Metabo, Milwaukee, Ramset, Red Head, Ryobi



The following are registered trademarks:
AEG® – AEG Power Tool Corp.
Bosch® – Robert Bosch Power Tool Corp.
SDS Plus® and SDS Max® are registered

trademarks of Robert Bosch Power Tool Corp.
B&D® – Black and Decker US, Inc.
Hilti® – Hilti of America, Inc.
Hitachi® – Hitachi Power Tools USA, Ltd.

Kango® – Kango Wolf Power Tools, Inc.
Makita® – Makita USA, Inc.
Metabo® – Metabo Corp.
Milwaukee® – Milwaukee Electric Tool Corp.

Porter Cable® – Porter Cable Corporation
Ramset® – Illinois Tool Works
Red Head® – Illinois Tool Works
Ryobi® – Ryobi America Corporation

SDS-PLUS® Drill Bits For Concrete and Masonry

SDS-PLUS® Shank Bits

Dia. (in.)	Drilling Depth (in.)	Overall Length (in.)	New Model No.
5/32	2	4 1/4	MDPL01504
	4	6 1/4	MDPL01506
3/16	2	4 1/4	MDPL01804
	4	6 1/4	MDPL01806
	6	8 1/4	MDPL01808
	8	10	MDPL01810
	10	12	MDPL01812
	12	14	MDPL01814
7/32	4	6 1/4	MDPL02106
	6	8 1/4	MDPL02108
	14	16	MDPL02116
	18	20	MDPL02120
1/4	2	4 1/4	MDPL02504
	4	6 1/4	MDPL02506
	6	8 1/4	MDPL02508
	9	11	MDPL02511
	12	14	MDPL02514
	14	16	MDPL02516
5/16	4	6 1/4	MDPL03106
	10	12	MDPL03112
3/8	4	6 1/4	MDPL03706
	8	10	MDPL03710
	10	12 1/4	MDPL03712
	16	18	MDPL03718
	22	24	MDPL03724
7/16	4	6 1/4	MDPL04306
	10	12 1/4	MDPL04312
1/2	4	6 1/4	MDPL05006
	8	10 1/4	MDPL05010
	10	12 1/4	MDPL05012
	16	18	MDPL05018
	22	24	MDPL05024
9/16	4	6 1/4	MDPL05606
	10	12 1/4	MDPL05612
	16	18	MDPL05618
5/8	6	8	MDPL06208
	10	12	MDPL06212
	16	18	MDPL06218
	22	24	MDPL06224
1 1/16	6	8	MDPL06808
3/4	6	8	MDPL07508
	8	10	MDPL07510
	10	12	MDPL07512
	16	18	MDPL07518
	22	24	MDPL07524
13/16	6	8	MDPL08108
27/32	6	8	MDPL08408
7/8	6	8	MDPL08708
	10	12 1/4	MDPL08712
	16	18	MDPL08718
1	8	10	MDPL10010
	16	18	MDPL10018

SDS-PLUS® Shank Bit
SDS-Plus bits use an asymmetrical-parabolic flute for efficient energy transmission and dust removal.



SDS-PLUS® Shank Bits - Retail Packs

Dia. (in.)	Drilling Depth (in.)	Overall Length (in.)	Quantity (per pack)	Model No.	
5/32	4	6 1/4	25	MDPL01506-R25	
	3/16	2	4 1/4	25	MDPL01804-R25
		4	6 1/4	25	MDPL01806-R25
		6	8 1/4	25	MDPL01808-R25
		8	10	25	MDPL01810-R25
		10	12	25	MDPL01812-R25
12	14	25	MDPL01814-R25		
7/32	4	6 1/4	25	MDPL02106-R25	
	6	8 1/4	25	MDPL02108-R25	
	8 1/4	11	25	MDPL02111-R25	
1/4	2	4 1/4	25	MDPL02504-R25	
	4	6 1/4	25	MDPL02506-R25	
	6	8 1/4	25	MDPL02508-R25	
	8 1/4	11	25	MDPL02511-R25	
5/16	4	6 1/4	25	MDPL03106-R25	
	4	6 1/4	25	MDPL03706-R25	
3/8	10	12 1/4	25	MDPL03712-R25	
	4	6 1/4	25	MDPL05006-R25	
1/2	10	12 1/4	25	MDPL05012-R25	
	6	8	20	MDPL06208-R20	



SDS-PLUS® Quad Head^{4x} Drill Bits

Dia. (in.)	Drilling Depth (in.)	Overall Length (in.)	Model No.
3/4	6	8	MDPL07508Q
	10	12	MDPL07512Q
	16	18	MDPL07518Q
7/8	6	8	MDPL08708Q
	10	12	MDPL08712Q
	16	18	MDPL08718Q
1	8	10	MDPL10010Q
	16	18	MDPL10018Q
1 1/8	8	10	MDPL11210Q
	16	18	MDPL11218Q



Quad Head^{4x}



Solid-tip carbide drill bit

Titen® Screw Drill Bit/Driver Product Data

Dia. (in.)	Drilling Depth (in.)	Overall Length (in.)	For Screw Dia. (in.)	Model No.
5/32	2 3/8	5	3/16	MDPL01505H
	3 1/8	6	3/16	MDPL01506H
	4 1/8	7	3/16	MDPL01507H
3/16	2 3/8	5	1/4	MDPL01805H
	3 1/8	6	1/4	MDPL01806H
	4 1/8	7	1/4	MDPL01807H

1. Product is sold individually.

Titen Screw Drill Bit/Driver - Bulk Packs

Dia. (in.)	Drilling Depth (in.)	Overall Length (in.)	For Screw Dia. (in.)	Model No.
5/32	2 3/8	5	3/16	MDPL01505H-R25
	4 1/8	7	3/16	MDPL01507H-R25
3/16	2 3/8	5	1/4	MDPL01805H-R25
	4 1/8	7	1/4	MDPL01807H-R25



Special hex adaptor (included with the Titen® Screw installation kit) allows the Titen installation tool to slide over the bit and lock in, ready to drive Titen concrete and masonry screws. Rotohammer must be in rotation-only mode before driving screws.

SDS-MAX® / Spline Drill Bits For Concrete and Masonry

SDS-MAX® and SDS-MAX Quad Head^{4x} Shank Bits

Dia. (in.)	Drilling Depth (in.)	Overall Length (in.)	Model No.
3/8	7 1/2	13	MDMC03713
	7 1/2	13	MDMX05013
1/2	15 1/2	21	MDMX05021
	7 1/2	13	MDMX05613
9/16	15 1/2	21	MDMX05621
	7 1/2	13	MDMX06213Q
5/8	15 1/2	21	MDMX06221Q
	30 1/2	36	MDMX06236Q
	15 1/2	21	MDMX06821Q
3/4	8	13	MDMX07513Q
	17	21	MDMX07521Q
	31	36	MDMX07536Q
13/16	17	21	MDMX08121Q
7/8	8	13	MDMX08713Q
	17	21	MDMX08721Q
1	8	13	MDMX10013Q
	17	21	MDMX10021Q
	31	36	MDMX10036Q
1 1/16	18	23	MDMX10623Q
1 1/8	12	17	MDMX11217Q
	17	21	MDMX11221Q
1 3/16	18	23	MDMX11823Q
	10	15	MDMX12515Q
	18	23	MDMX12523Q
1 1/4	31	36	MDMX12536Q
	12	17	MDMX13717Q
1 3/8	18	23	MDMX13723Q
	18	23	MDMX15023Q
1 3/4	18	23	MDMX17523Q
2	18	23	MDMX20023Q

Model numbers ending with "Q" denote Quad Head^{4x} bits

**SDS-MAX®
Shank Bit**



Quad Head^{4x}
Model numbers ending with "Q" denote Quad Head^{4x} bits.

Spline Shank Bits

Dia. (in.)	Drilling Depth (in.)	Overall Length (in.)	Model No.
3/8	5	10	MDSP03710
	8	13	MDSP03713
	11	16	MDSP03716
7/16	8	13	MDSP04313
	5	10	MDSP05010
1/2	8	13	MDSP05013
	11	16	MDSP05016
	17	22	MDSP05022
	22	29	MDSP05029
	31	36	MDSP05036
9/16	8	13	MDSP05613
	11	16	MDSP05616
	18	23	MDSP05623
5/8	5	10	MDSP06210
	8	13	MDSP06213
	11	16	MDSP06216
	17	22	MDSP06222
	24	29	MDSP06229
1	31	36	MDSP06236
	8	13	MDSP06813
	11	16	MDSP06816
3/4	5	10	MDSP07510
	8	13	MDSP07513
	11	16	MDSP07516
	17	22	MDSP07522
	24	29	MDSP07529
7/8	31	36	MDSP07536
	11	16	MDSP08716
	17	22	MDSP08722
1	31	36	MDSP08736
	11	16	MDSP10016
	17	22	MDSP10022
1 1/8	31	36	MDSP10036
	11	16	MDSP11216
1 1/4	17	22	MDSP11222
	11	16	MDSP12516
1 3/8	17	22	MDSP12522
	11	16	MDSP13716
1 1/2	17	22	MDSP13722
	11	16	MDSP15016
1 3/4	17	22	MDSP15022
	17	22	MDSP17522
2	17	22	MDSP20022

**Spline
Shank Bit**



Spline Shank Bits continued on the next page.

SDS-PLUS® Solid-Tip Carbide Drill Bits

Model No.	Diameter (in.)	Total length (in.)	Drilling Depth (in.)
MDPL01804S	3/16	4 1/4	2
MDPL01806S	3/16	6 1/4	4
MDPL01808S	3/16	8 1/4	6
MDPL01812S	3/16	12	10
MDPL02506S	1/4	6 1/4	4
MDPL02508S	1/4	8 1/4	6
MDPL02512S	1/4	12	10
MDPL03106S	5/16	6 1/4	4
MDPL03112S	5/16	12	10
MDPL03706S	3/8	6 1/4	4
MDPL03712S	3/8	12 1/4	10
MDPL05006S	1/2	6 1/4	4
MDPL05012S	1/2	12 1/4	10
MDPL05606S	9/16	6	4
MDPL05612S	9/16	12	10

Spline / Straight Shank Drill Bits For Concrete and Masonry

Spline Shank Quad Head^{4x} Bits

Dia. (in.)	Drilling Depth (in.)	Overall Length (in.)	Model No.
5/8	5	10	MDSP06210Q
	11	16	MDSP06216Q
	17	22	MDSP06222Q
	24	29	MDSP06229Q
	31	36	MDSP06236Q
11/8	11	16	MDSP06816Q
3/4	5	10	MDSP07510Q
	11	16	MDSP07516Q
	17	22	MDSP07522Q
	24	29	MDSP07529Q
	31	36	MDSP07536Q
7/8	11	16	MDSP08716Q
	17	22	MDSP08722Q
1	11	16	MDSP10016Q
	17	22	MDSP10022Q
	31	36	MDSP10036Q
1 1/8	11	16	MDSP11216Q
	17	22	MDSP11222Q
1 1/4	11	16	MDSP12516Q
	17	22	MDSP12522Q
	31	36	MDSP12536Q
1 3/8	11	16	MDSP13716Q
	17	22	MDSP13722Q
1 1/2	17	22	MDSP15022Q
1 3/4	18	23	MDSP17523Q
2	18	23	MDSP20023Q

Spline Shank Bit



Quad Head^{4x}

Straight Shank Bits

Dia. (in.)	Drilling Depth (in.)	Overall Length (in.)	New Model No.
1/8	1 3/8	3	MDB01203
3/16	1 1/8	3 1/2	MDB01803
	4	6	MDB01806
1/4	2 1/8	4	MDB02504
	4	6	MDB02506
	10	12	MDB02512
5/16	2 3/4	4 3/4	MDB03104
	4	6	MDB03106
3/8	4	6	MDB03706
	10	12	MDB03712
7/16	4	6	MDB04306
	4	6	MDB05006
1/2	10	12	MDB05012
	22	24	MDB05024
5/8	3 1/2	6	MDB06206
	10	12	MDB06212
3/4	22	24	MDB06224
	4	6	MDB07506
7/8	10	12	MDB07512
	4	6	MDB08706
1	10	12	MDB08712
	4	6	MDB10006
1	10	12	MDB10012

Straight Shank Bit



1. Bits have recessed shank to fit Titen® screws and other masonry screw installation tools. They also work in three-jaw style chucks.

Straight Shank Bits - Single Bit Retail Blister Packs - Cartons of 25

Dia. (in.)	Length (in.)	Model No.
5/32	3 1/2	MDB15312-RB
	4 1/2	MDB15412-RB
3/16	3 1/2	MDB18312-RB
	4 1/2	MDB18412-RB
	5 1/2	MDB18512-RB



'A' Taper Shank Bits

Dia. (in.)	Drilling Depth (in.)	Overall Length (in.)	Model No.
1/2	7	9	MDA05007
5/8	7	9	MDA06207
3/4	16	18	MDA07516

'A' Taper Bit



Straight Shank Bits - Retail Packs

Dia. (in.)	Drilling Depth (in.)	Overall Length (in.)	Quantity (per pack)	New Model No.
1/8	1 3/8	3	25	MDB01203-R25
3/16	1 1/8	3 1/2	25	MDB01803-R25
	4	6	25	MDB01806-R25
1/4	2 1/8	4	25	MDB02504-R25
	4	6	25	MDB02506-R25
5/16	2 3/4	4 3/4	25	MDB03104-R25
	4	6	25	MDB03106-R25
3/8	4	6	25	MDB03706-R25
1/2	4	6	25	MDB05006-R25
5/8	4	6	20	MDB06206-R20

Rebar Cutters/Adaptors For Concrete and Masonry

Rebar Cutters**

When hole placement conflicts with rebar or wire mesh, these bits enable the rebar to be removed so the hole can be drilled to the proper depth. Rebar cutters are separate from shanks. Shanks work with all sizes of rebar cutters. Overall length is approximately 15".

Dia. (in.)	Drilling Depth (in.)	Model No.
½	12	MCR05012
⅝	12	MCR06212
¾	12	MCR07512
7⁄8	12	MCR08712
1	12	MCR10012

** After drilling through the reinforcement or plate, remove debris from the hole and resume drilling with carbide tipped drill bit.



Rebar Cutter Detail



Rebar Cutter

Plate Cutters**

Similar to Rebar Cutters, these bits are designed for cutting through steel base plates when it is necessary to enlarge the fixture hole. These bits can also be used as rebar cutters. Plate cutters are separate from shanks. Shanks work with all sizes of plate cutters.

Dia. (in.)	Drilling Depth (in.)	Model No.
½	12	MCP05012
⅝	12	MCP06212
¾	12	MCP07512
7⁄8	12	MCP08712
1	12	MCP10012

** After drilling through the reinforcement or plate, remove debris from the hole and resume drilling with carbide tipped drill bit.



Plate Cutter Detail



Plate Cutter

Shanks for Rebar and Plate Cutters

Shank Style	Model No.	Description
Straight	MC	For use in drills with jawed chucks. Use in rotation mode only.
SDS-Plus®	MCSDP	For use in SDS-Plus® style drills. Use in rotation only.
SDS-Max®	MCSDM	For use in SDS-Max® style drills. Shank design allows rotation only.
Spline	MCS	For use in Spline style drills. Shank design allows rotation only.



SDS-Plus Shank



Spline Shank



SDS-MAX® to SDS-PLUS® Adaptor



Spline to SDS-PLUS Adaptor



SDS-Top (T-ET style) to SDS-PLUS Adaptor

Drill Bit Shank Adaptors

Description (shank style to bit type)	Model No.
SDS-MAX to SDS-Plus Adaptor	ADMX2PL
Spline to SDS-Plus Adaptor	ADSP2PL
SDS-top to SDS-Plus Adaptor	ADST2PL

Demolition Bits For Concrete and Masonry



Demolition Chisels & Bits

Simpson Strong-Tie® chisels are made of toughened steel with special surface treatment that improves performance. The superior tempering process creates a hardened surface that is more wear resistant and enables the working point to be re-sharpened, which extends the life of the tool.

Simpson Strong-Tie® Demolition Chisels and Bits come in various shank styles to fit virtually any demolition tool.

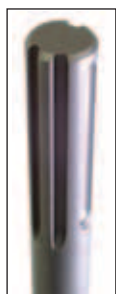

SDS Max®



Spline
(Design disables rotohammer rotation.)



3/4" Hex

Bull Point Chisels: General Concrete and Masonry Demolition

Shank Type	Overall Length (in.)	Model No.
SDS-Plus	10	CHPLBP10
SDS-Max	12	CHMXBP12
	18	CHMXBP18
Spline	12	CHSPBP12
	18	CHSPBP18
3/4" Hex	12	CHHBP12
	18	CHHBP18



Bull Point Chisel

Clay Spades: Clay and Other Rock-Free Soil Cutting

Shank Type	Head Width (in.)	Overall Length (in.)	Model No.
Spline	5 5/8	16	CHSPCS53716
3/4" Hex	5 5/8	16	CHHCS53716



Clay Spade

Scrapers: Removing Tiles, Flooring and Other Materials

Shank Type	Head Width (in.)	Overall Length (in.)	Model No.
SDS-Plus	3/4	10	CHPLF07510
	1 1/2	10	CHPLSC15010
SDS-Max	2	12	CHMXSCP20012
Spline	2	12	CHSPSCP20012



Scraper

Flat Chisels: General Concrete and Masonry Demolition

Shank Type	Head Width (in.)	Overall Length (in.)	Model No.
SDS-Max	1	12	CHMXF10012
	1	18	CHMXF10018
Spline	1	12	CHSPF10012
	1	18	CHSPF10018
3/4" Hex	1	12	CHHF10012
3/4" Hex	1	18	CHHF10018



Flat Chisel

Asphalt Cutters: Asphalt, Hardpan and Compacted Soil Cutting

Shank Type	Head Width (in.)	Overall Length (in.)	Model No.
SDS-Max	3 1/2	16	CHMXAC35016
3/4" Hex	3 1/2	16	CHHAC35016



Asphalt Cutter

Demolition Bits For Concrete and Masonry

Scalers: Removing Large Quantities of Material

Shank Type	Head Width (in.)	Overall Length (in.)	Model No.
SDS-Max	1½	12	CHMXSC15012
	2	12	CHMXSC20012
	3	12	CHMXSC30012
Spline	1½	12	CHSPSC15012
	2	12	CHSPSC20012
	3	12	CHSPSC30012
¾" Hex	2	12	CHHSC20012
	3	12	CHHSC30012

Ground Rod Drivers: Driving in Ground Rods

Shank Type	Head Width (in.)	Overall Length (in.)	Model No.
SDS-Max	¾	10 ¼	CHMXRD08710
Spline	¾	10 ¼	CHSPRD08710



Brushing Tools: One Piece Concrete and Asphalt Surface Roughening

Shank Type	Head Width (in.)	Overall Length (in.)	Model No.
SDS-Max	1 ¾	9 ½	CHMXBT17509
Spline	1 ¾	9 ¼	CHSPBT17509
¾" Hex	1 ¾	9 ¼	CHHBT17509



Core Bits For Concrete and Masonry

Core Bits

Simpson Strong-Tie® core bits are made to the same exacting standards as our standard carbide tipped drill bits. They utilize a centering bit to facilitate accurate drilling in combination hammer/drill mode.

One Piece Core Bits with Centering Bit - SDS Max® Shank

Dia. (in.)	Drilling Depth (in.)	Overall Length (in.)	Model No.
1½	6 ¼	11 ¾	CBMX15011
	16 ¾	22	CBMX15022
2	6 ¼	11 ¾	CBMX20011
	16 ¾	22	CBMX20022
2 ¾	6 ¼	11 ¾	CBMX26211
	16 ¾	22	CBMX26222
3 ½	16 ¾	22	CBMX35022
4	6 ¼	11 ¾	CBMX40011
	16 ¾	22	CBMX40022
5	6 ¼	11 ¾	CBMX50011
	16 ¾	22	CBMX50022

NOTE: With 1 piece bits, once coring is begun the centering bit must be removed using ejector pin. Core bit bodies are 2 ¼" deep.

One Piece Core Bits with Centering Bit - Spline Shank

Dia. (in.)	Drilling Depth (in.)	Overall Length (in.)	Model No.
1½	6 ¼	11 ¾	CBSP15012
	16 ¾	22	CBSP15022
2	6 ¼	11 ¾	CBSP20011
	16 ¾	22	CBSP20022
2 ¾	6 ¼	11 ¾	CBSP26211
	16 ¾	22	CBSP26222
3 ½	6 ¼	11 ¾	CBSP31211
	16 ¾	22	CBSP31222
3 ½	6 ¼	11 ¾	CBSP35011
	16 ¾	22	CBSP35022
5	6 ¼	11 ¾	CBSP50011
	16 ¾	22	CBSP50022



One Piece Core Bit
Transfers energy efficiently

Drill Bits

Core Bit Replacement Parts

Core Bit Center Pilot Bit

Dia. (in.)	Overall Length (in.)	New Model No.
¾	4 ¾	CTRBTF04304

Ejector Key

Dia. (in.)	New Model No.
¾	CDBEJKEY



Drill Bit Warranty Claims *Definitions & Procedures*

FAILURES:

Warranty claims will occur on less than 1/2 of 1% of the Simpson Strong-Tie Anchor Systems® carbide-tipped bits used. This estimate is based on experience with many millions of bits in various tools and materials.

The following information has been produced to enable you to improve your ability to fairly determine defects. **BITS ARE WARRANTED FOR REPLACEMENT ONLY AND IN NO CIRCUMSTANCES WILL SIMPSON BE LIABLE FOR MERCHANTABILITY OR LOSS OF SERVICE.**

If the defect is not obvious, please return the bit to our home office in Pleasanton, CA. Warranty decisions will be made within 48 hours after receiving the returned item(s).

FOR BEST BIT WEAR LIFE / PRODUCTION OUTPUT USE THE FOLLOWING GUIDELINES:

- Ensure that the tool holders are in good shape. Deformation of the slots or contours of the bit shanks are a positive indication of tool holder wear. Worn tool holders reduce rotational and energy transfer efficiencies. Repair or replacement is required for efficient hole production.
- The lines of force should be kept as close as possible to 90° to the axis. The tool and bit should be kept directly in line with the hole.
- The bit should not be used as a hammer support when working in walls. Such use reduces energy transfer, slows rotation, accelerates flute wear, and is indicative of poor workmanship. The hammer should be supported at all times when working in walls.
- Only a slight "guiding pressure" is required to assist hammers when working on a horizontal surface. The weight of the hammer itself is almost sufficient for optimum production. Some guiding pressure absorbs recoil and assists in hole production. Obviously, compensation for the pressure which the weight of the hammer produces, must be made when working in ceilings and walls. Caution must be taken not to apply too much pressure as this retards hole production.
- Generally speaking, when a bit becomes very dull, it should be retired; it has done its job. Note: resharpening of drill bits voids the warranty.
- Bit life is generally measured by flute wear. We measure the diameter of the flutes directly behind the tip (area of most wear) and compare that reading to the diameter at the top of the bit (area of least wear). The resultant difference indicates wear life. If a measurement is greater than the standard shown in the chart, the bit is considered to be out of warranty.

Bit Dia. (in.)	Wear Diff. (in.)	Bit Dia. (in.)	Wear Diff. (in.)	Bit Dia. (in.)	Wear Diff. (in.)	Bit Dia. (in.)	Wear Diff. (in.)
3/16	.008	1/2	.020	7/8	.028	1 3/8	.043
1/4	.008	9/16	.024	1	.032	1 1/2	.048
5/16	.012	5/8	.024	1 1/8	.036	1 3/4	.048
3/8	.016	1 1/16	.024	1 1/4	.039	2	.048
7/16	.020	3/4	.024	-	-	-	-

BIT FAILURES CAN OCCUR IN THE FOLLOWING WAYS:

Carbide tip fractures:

Carbide fracture can be caused by two primary reasons: hitting an extremely hard foreign object in the concrete or hitting and staying on reinforcing steel. Steel strikes are readily identifiable. The bit steel will be damaged as well as the tip itself. The operator should cease hole production when the bit stops turning and start a new hole. Bits damaged due to steel strikes are not warranted.

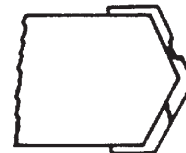

Shaft Breakage behind the head:

If the break area shows jagged steel and no notch, the bit has been over-torqued by jamming in the hole. The bit is not covered by warranty.



Shank transition area on upper shaft is polished:

This is a positive indication that the bit has been used to produce deeper holes than it should. This means that debris has not been able to clear the hole readily, producing excessive heat buildup, which destroyed the bit-no warranty replacement. (User should purchase longer bits or use a lighter-duty hammer with small diameter bits).



Tool holder slots, dimples, or recesses show wear:

This indicates the hammer tool holder should be repaired or replaced-no warranty replacement.



Supplemental Topics for Anchors

G1. Base Materials

"Base material" is a generic industry term that refers to the element or substrate to be anchored to. Base materials include concrete, brick, concrete block (CMU) and structural tile, to name a few. The base material type will determine the type of fastener for the application. The most common type of base material where adhesive and mechanical anchors are used is concrete.

Concrete – Concrete can be cast-in-place or precast concrete. Concrete has excellent compressive strength, but relatively low tensile strength. Cast-in-place (or sometimes called "poured in place") concrete is placed in forms erected on the building site. Cast-in-place concrete can be either normal-weight or lightweight concrete. Lightweight concrete is often specified when it is desirable to reduce the weight of the building structure.

Lightweight concrete differs from normal-weight concrete by the weight of aggregate used in the mixture. Normal-weight concrete has a unit weight of approximately 150 pounds per cubic foot compared to approximately 115 pounds per cubic foot for lightweight concrete.

The type of aggregate used in concrete can affect the tension capacity of an adhesive anchor. Presently, the relationship between aggregate properties and anchor performance is not well understood. A recent study based on a limited test program has shown that in relative terms, concrete with harder and more dense aggregates tend to yield greater anchor tension capacities. Conversely, use of softer, less dense aggregates tends to result in lower anchor tension capacities. Research in this area is ongoing. Test results should not be assumed to be representative of expected performance in all types of concrete aggregate.

Prefabricated concrete is also referred to as "precast concrete". Precast concrete can be made at a prefabricating plant or site-cast in forms constructed on the job. Precast concrete members may be solid or may contain hollow cores. Many precast components have thinner cross sections than cast in place concrete. Precast concrete may use either normal or lightweight concrete. Reinforced concrete contains steel bars, cable, wire mesh or random glass fibers. The addition of reinforcing material enables concrete to resist tensile stresses which lead to cracking.

The compressive strength of concrete varies according to the proportions of the components in the mixture. The desired compressive strength of the concrete will be specified according to the application. Water and cement content of the mix is the main determinant of the compressive strength.

The compressive strength of concrete can range from 2,000 psi to over 20,000 psi, depending on the mixture and how it is cured. Most concrete mixes are designed to obtain the desired properties within 28 days after being cast.

Concrete Masonry Units (CMU) – Block is typically formed with large hollow cores. Block with a minimum 75% solid cross section is called solid block even though it contains hollow cores. In many parts of the country building codes require steel reinforcing bars to be placed in the hollow cores, and the cores to be filled solid with grout.

In some areas of the eastern United States, past practice was to mix concrete with coal cinders to make cinder blocks. Although cinder blocks are no longer made, there are many existing buildings where they can be found. Cinder blocks require special attention as they soften with age.

Brick – Clay brick is formed solid or with hollow cores. The use of either type will vary in different parts of the United States. Brick can be difficult to drill and anchor into. Most brick is hard and brittle. Old, red clay brick is often very soft and is easily over-drilled. Either of these situations can cause problems in drilling and anchoring. The most common use of brick today is for building facades (curtain wall or brick veneer) and not for structural applications. Brick facade is attached to the structure by the use of brick ties spaced at intervals throughout the wall. In older buildings, multiple widths, or "wythes" of solid brick were used to form the structural walls. Three and four wythe walls were common wall thicknesses.

Clay Tile – Clay tile block is formed with hollow cores and narrow cavity wall cross sections. Clay tile is very brittle, making drilling difficult without breaking the block. Caution must be used in attempting to drill and fasten into clay tile.

MECHANICAL ANCHORS

M1. Pre-Load Relaxation

Expansion anchors that have been set to the required installation torque in concrete will experience a reduction in pre-tension (due to torque) within several hours. This is known as pre-load relaxation. The high compression stresses placed on the concrete cause it to deform which results in a relaxation of the pre-tension force in the anchor. Tension in this context refers to the

G2. Anchor Failure Modes

The failure modes for both mechanical and adhesive anchors depends on a number of factors including the anchor type and geometry, anchor material mechanical properties, base material mechanical properties, loading type and direction, edge distance, spacing and embedment depth.

Six different failure modes are generally observed for mechanical and adhesive anchors installed in concrete under tension loading: concrete cone breakout, concrete edge breakout, concrete splitting, anchor slip, adhesive bond, and steel fracture. Three failure modes are generally observed for mechanical and adhesive anchors installed in concrete under shear loading: concrete edge breakout, pryout and steel failure.

Concrete Cone Breakout Failure

This failure mode is observed for both mechanical and adhesive anchors installed at shallow embedment depths under tension loading. This failure mode is also observed for groups of mechanical and adhesive anchors installed at less than critical spacing.

Concrete Edge Breakout Failure

This failure mode is observed for both mechanical and adhesive anchors installed at less than critical edge distance under either tension or shear loading. For this failure mode neither the adhesive nor mechanical anchor fail, but rather the concrete fails. According to Simpson Strong-Tie testing, the tension load at which failure occurs is correlated to the concrete aggregate performance. Other factors may also influence tension load.

Concrete Splitting Failure

This failure mode is observed for both mechanical and adhesive anchors installed in a "thin" concrete member under tension loading.

Anchor Slipping Failure

This failure mode is observed for mechanical anchors under tension loading in which the anchor either pulls out of the member (e.g.- a Drop-In Anchor installed through metal deck and into a concrete fill) or the anchor body pulls through the expansion clip (e.g.- a Wedge-All® anchor installed at a deep embedment depth in concrete).

Adhesive Bond Failure

This failure mode is observed for adhesive anchors under tension loading in which a shallow concrete cone breakout is observed along with an adhesive bond failure at the adhesive/base material interface. The concrete-cone breakout is not the primary failure mechanism.

Steel Fracture

This failure mode is observed for both mechanical and adhesive anchors under tension or shear loading where the concrete member thickness and mechanical properties along with the anchor embedment depth, edge distance, spacing, and adhesive bond strength (as applicable), preclude base material failure.

Pryout Failure

This failure mode is observed for both mechanical and adhesive anchors installed at shallow embedment under shear loading.

G3. Corrosion resistance

Metal anchors and fasteners will corrode and may lose load-carrying capacity when installed in corrosive environments or exposed to corrosive materials. There are many environments and materials which may cause corrosion including ocean salt air, fire-retardants, fumes, fertilizers, preservative-treated wood, dissimilar metals, and other corrosive elements.

Some types of preservative-treated woods and fire-retardant woods are known to be especially caustic to zinc and can cause anchors and fasteners to deteriorate. Zinc-coated anchors and fasteners should not be placed in contact with treated wood unless adequately verified to be suitable for such contact. See page 12 in this catalog and contact the wood supplier for additional information.

Some products are available with additional coating options or in stainless steel to provide additional corrosion resistance.

Highly-hardened fasteners can experience premature failure due to hydrogen-assisted stress corrosion cracking when loaded in environments producing hydrogen. Simpson Strong-Tie® recommends that such fasteners be used in dry, interior and non-corrosive environments only.

internal stresses induced in the anchor as a result of applied torque and does not refer to anchor capacity. Historical data shows it is normal for the initial tension values to decrease by as much as 40–60% within the first few hours after installation. Retorquing the anchor to the initial installation torque is not recommended, or necessary.

Supplemental Topics for Anchors

SET-XP Adhesive

Insert Diameter (in.)	Acceptable Hole Diameter Range (in.)	Acceptable Load Reduction Factor
1/2	5/8 – 3/4	1.0
5/8	3/4 – 15/16	1.0
3/4	7/8 – 1 1/8	1.0
7/8	1 – 1 1/16	1.0
1	1 1/8 – 1 1/2	1.0

SET and ET-HP Adhesives

Insert Diameter (in.)	Acceptable Hole Diameter Range (in.)	Acceptable Load Reduction Factor
3/8	1/2 – 3/4	1.0
1/2	5/8 – 15/16	1.0
5/8	3/4 – 1 1/8	1.0
3/4	7/8 – 1 1/16	1.0
7/8	1 – 1 1/2	1.0
1	1 1/8 – 1 11/16	1.0
1 1/8	1 1/4 – 1 7/8	1.0
1 1/4	1 3/8 – 2 1/16	1.0
1 3/8	1 1/2 – 2 1/4	1.0

Acrylic Adhesives

Insert Diameter (in.)	Acceptable Hole Diameter Range (in.)	Acceptable Load Reduction Factor
3/8	7/16 – 1/2	1.0
1/2	9/16 – 5/8	1.0
5/8	11/16 – 3/4	1.0
3/4	13/16 – 7/8	1.0
7/8	1	1.0
1	1 1/16 – 1 1/8	.75 for 1 1/8 only

ADHESIVE ANCHORS

A1. Oversized Holes

The performance data for adhesive anchors are based upon anchor tests in which holes were drilled with carbide-tipped drill bits of the same diameter listed in the product's load table. Additional static tension tests were conducted to qualify anchors installed with SET, SET-XP, EDOT™ and AT adhesives for installation in holes with diameters larger than those listed in the load tables. The tables indicate the acceptable range of drilled-hole sizes and the corresponding allowable tension-load reduction factor (if any). The same conclusions also apply to the published allowable shear load values. Drilled holes outside of the range shown below are not recommended.

A2. Core-Drilled Holes

The performance data for adhesive anchors are based upon anchor tests in which holes were drilled with carbide-tipped drill bits. Additional static tension tests were conducted to qualify anchors installed with SET, ET-HP and AT anchoring adhesives for installation in holes drilled with diamond-core bits. In these tests, the diameter of the diamond-core bit matched the diameter of the carbide-tipped drill bit recommended in the product's load table. The test results showed that no reduction of the published allowable tension load for SET, ET-HP and AT anchoring adhesives is necessary for this condition. The same conclusions also apply to the published allowable shear loads.

A3. Installation in Damp, Wet and Submerged Environments

SET-XP® adhesive: The performance data for adhesive anchors using SET-XP epoxy anchoring adhesive are based upon tests according to ICC-ES AC308. This criterion requires adhesive anchors that are to be installed in outdoor environments to be tested in water-saturated concrete holes that have been cleaned with less than the amount of hole cleaning recommended by the manufacturer. A product's sensitivity to this installation condition is considered in determining the product's "Anchor Category" (strength reduction factor). SET-XP™ may be installed in dry or water-saturated concrete.

Based on Reliability Testing per ICC-ES AC308

- **Dry Concrete** – Cured concrete whose moisture content is in equilibrium with surrounding non-precipitate atmospheric conditions.
- **Water-Saturated Concrete** – Cured concrete whose internal aggregate materials are soaked with moisture.
- **Submerged Concrete** – Cured concrete that is covered with water and water saturated.
- **Water-Filled Hole** – Drilled hole in water-saturated concrete that is clean yet contains standing water at the time of installation.

SET, ET-HP, EDOT, AT and VGC: The performance data for adhesive anchors using SET, ET-HP, EDOT, AT and VGC adhesives are based upon tests in which anchors are installed in dry holes. Additional static tension tests were conducted for some products in damp holes, water-filled holes and submerged holes. The test results show that no reduction of the published allowable tension load is necessary for SET, ET-HP, EDOT, and AT adhesives in damp holes, or for SET and AT adhesives in water-filled holes. For SET, ET-HP, and AT adhesives in submerged holes, the test results show that a reduction factor of 0.60 is applicable. The same conclusions also apply to the published allowable shear load values.

Based on Service Condition Testing per ICC-ES AC58

- **Dry Concrete** – Cured concrete whose moisture content is in equilibrium with surrounding non-precipitate atmospheric conditions.

- **Damp Hole** - A damp hole, as defined in ASTM E1512 and referenced in ICC-ES AC58, is a drilled hole that has been properly drilled, cleaned and then is filled with standing water for seven days. After seven days, the standing water is blown out of the hole with compressed air and the adhesive anchor is installed.
- **Water-Filled Hole** - A water-filled hole is defined similarly to a damp hole; however, the standing water is not blown out of the hole. Instead, the adhesive is injected directly into the water-filled hole (from the bottom of the hole up) and the insert is installed.
- **Submerged Hole** - A submerged hole is similar to a water-filled hole with one major exception – in addition to standing water within the hole; water also completely covers the surface of the base material as well. Note that drilling debris and sludge should be removed from the drilled hole prior to installation. ASTM E1512 and ICC-ES AC58 do not address this condition.

A4. Elevated In-Service Temperature

The performance of all adhesive anchors is affected by elevated base material temperature. The in-service temperature sensitivity table provided for each adhesive provides the information necessary to apply the appropriate load-adjustment factor to either the allowable tension based on bond strength or allowable shear based on concrete edge distance based for a given base material temperature. While there is no commonly used method to determine the exact load-adjustment factor, there are a few guidelines to keep in mind when designing an anchor that will be subject to elevated base-material temperature. In any case, the final decision must be made by a qualified design professional using sound engineering judgment:

- When designing an anchor connection to resist wind and/or seismic forces only, the effect of fire (elevated temperature) may be disregarded.
- The base-material temperature represents the average internal temperature and hence, the temperature along the entire bonded length of the anchor.
- The effects of elevated temperature may be temporary. If the in-service temperature of the base material is elevated such that a load-adjustment factor is applicable, but over time the temperature is reduced to a temperature below which a load-adjustment factor is applicable, the full allowable load based on bond strength is still applicable. This is applicable provided that the degradation temperature of the anchoring adhesive (350° F for SET-XP, SET, ET-HP, and AT adhesives) has not been reached.

A5. Creep Under Long-Term Loads

Creep is the slow continuous deformation of a material under constant stress. Creep occurs in many construction materials, including concrete and steel when the stress is great enough. The creep characteristics of adhesives are product-dependent. Adhesive anchors that are not creep-resistant can pull out slowly over time when sustained tensile loads are applied.

Because of the creep phenomenon, it is important for Designers to consider the nature of the applied tension loads and to determine if the tension loads will be continuously applied to the anchor over the long-term. If this is the case, a product that is suitable for resisting sustained loads over the long-term must be selected.

All Simpson Strong-Tie® anchoring adhesives (SET-XP, SET, ET-HP, EDOT, AT and VGC) have been qualified for resisting long-term loads through ICC-ES AC58 or AC308 "creep tests" in which an anchor is loaded and monitored for movement over time. According to AC58 and AC308, anchors that pass the creep test are determined to be suitable for resisting long-term tensile loads.

Allowable Stress Design (ASD) Method

In allowable stress design (ASD), the Designer must size the anchorage such that the service load does not exceed the allowable load for any anchor:

$$\begin{aligned} T_{service} &\leq T_{allowable} \\ V_{service} &\leq V_{allowable} \end{aligned}$$

The Designer must read the allowable load from the applicable table and adjust the allowable load for all applicable design parameters for the anchor, such as spacing, edge distance, in-service temperature or allowable-stress increase for short-term loads. Load-adjustment factors for anchors are applied cumulatively. For adhesive anchors, the designer must also ensure that the service load does not exceed the allowable load of the steel insert.

For anchors subjected to simultaneous tension and shear loading, the following equation must be satisfied, where the value of n is product-specific. Use a value of $n=1$ unless otherwise specified in the applicable products' load table.

$$\left(\frac{T_{service}}{T_{allowable}}\right)^n + \left(\frac{V_{service}}{V_{allowable}}\right)^n \leq 1.0$$

Linear interpolation of allowable loads between embedment depths and/or compressive strengths shown in the load tables is permitted. Linear interpolation of load-adjustment factors in the edge distance and spacing tables is also permitted.

The allowable loads in this catalog are derived from full-scale testing, calculations, and/or experience. In general, the allowable load is determined by taking the average ultimate load from full scale tests and dividing by a safety factor (Ω).

$$T_{allowable} = \frac{\bar{T}_{ultimate}}{\Omega}; \quad V_{allowable} = \frac{\bar{V}_{ultimate}}{\Omega}$$

For some anchors, the average ultimate load and/or allowable load is also controlled by anchor displacement limits.

The allowable loads for steel inserts used with adhesive anchors is determined as follows:

For threaded rod: $T_{allowable} = 0.33 F_u A_g$; $V_{allowable} = 0.17 F_u A_g$

For Grade 60 rebar: $T_{allowable} = (24,000 \text{ psi}) A_g$; $V_{allowable} = 0.17(90,000 \text{ psi}) A_g$

Where:

A_g = Gross cross-sectional area of the insert

Threaded Insert Steel Type	F_u (psi)
F1554, Grade 36	58,000
A193, Grade B7	125,000
304/316 Stainless (Diam. $\leq \frac{5}{8}$ ")	100,000
304/316 Stainless (Diam. $\geq \frac{3}{4}$ ")	85,000

Where:

F_u = Ultimate tensile strength of steel insert

Strength Design (SD) Method

(Under ACI 318 APPENDIX D, ICC-ES AC193, and ICC-ES AC308)

In strength design (SD), the Designer must size the anchorage such that the required strength (i.e. factored load) does not exceed the lowest design strength of the anchor or anchor group considering all possible failure modes.

$$\begin{aligned} N_{ua} &\leq \phi N_n \\ V_{ua} &\leq \phi V_n \end{aligned}$$

Calculations are performed in accordance with the applicable design standards: ICC-ES AC193 and ACI 318 Appendix D for mechanical anchors and ICC-ES AC308 for adhesive anchors. The additional design provisions of AC308 are shown elsewhere in this catalog.

The nominal strengths and design data in this catalog are derived from full-scale testing and calculations in accordance with ACI 355.2, ICC-ES AC193 and ICC-ES AC308. In general, nominal strengths are 5% fractile strengths calculated using the average ultimate load, and standard deviation of full-scale test results. A 5% fractile strength is the nominal strength for which there is a 90% confidence that there is a 95% probability of the actual strength exceeding the nominal strength.

For anchors that are designed using ACI 318 Appendix D, AC193, or AC308, it is possible to convert design strengths (i.e. ϕN_n or ϕV_n) to allowable loads using the following approach from AC193 (dated February 2008) and AC308 (dated January 2009):

$$T_{allowable, ASD} = \frac{\phi N_n}{\alpha} \quad \text{and} \quad V_{allowable, ASD} = \frac{\phi V_n}{\alpha}$$

Where:

$T_{allowable, ASD}$ = Allowable tension load

$V_{allowable, ASD}$ = Allowable shear load

ϕN_n = Lowest design strength of an anchor or anchor group in tension as

determined per ACI 318 Appendix D, AC193, AC308 and the IBC.

ϕV_n = Lowest design strength of an anchor or anchor group in shear as determined per ACI 318 Appendix D, AC193, AC308 and the IBC.

α = Conversion factor calculated as a weighted average of the load factors for the controlling load combination. In addition, α shall include all applicable factors to account for non-ductile failure modes and required over-strength.

Interaction shall be calculated as follows:

For tension loads, $T \leq 0.2 T_{allowable}$, the full allowable load in shear shall be permitted.

For shear loads, $V \leq 0.2 V_{allowable}$, the full allowable load in tension shall be permitted.

For all other cases: $\frac{T}{T_{allowable}} + \frac{V}{V_{allowable}} \leq 1.2$

ICC-ES AC308 Strength Design Method for Adhesive Anchors

Strength design calculations are performed in accordance with ICC-ES AC308, which makes the following amendments to ACI 318 Appendix D:

3.3 Strength design - amendments to ACI 318:

3.3.1 **Adhesive anchors:** This section provides amendments to ACI 318 Appendix D as required for the strength design of adhesive anchors. In conformance with ACI 318, all equations are expressed in inch-pound units.

3.3.1.1 Add or revise Section D.4.1.2, D.4.1.4, D.5.2.9, D.5.2.10, D.5.3.7, D.5.3.8, D.5.3.9, D.5.3.10, D.5.3.11, D.5.3.12, D.5.3.13, D.5.3.14, D.6.3.2 and D.8.8 to ACI 318 as follows:

D.4.1.2 – In Eq. (D-1) and (D-2), ϕN_n and ϕV_n are the lowest design strengths determined from all appropriate failure modes. ϕN_n is the lowest design strength in tension of an anchor or group of anchors as determined from consideration of ϕN_{nsa} , either ϕN_a or ϕN_{ag} and either ϕN_{cb} or ϕN_{cbg} . ϕV_n is the lowest design strength in shear of an anchor or a group of anchors as determined from consideration of: ϕV_{sa} , either ϕV_{cb} or ϕV_{cbg} , and either ϕV_{cp} or ϕV_{cpg} . For adhesive anchors subjected to tension from sustained loading, see D.4.1.4.

D.4.1.4 – For adhesive anchors subjected to tension resulting from sustained loading, a supplementary design analysis shall be performed using Eq. (D-1) whereby N_{ua} is determined from the sustained load alone, e.g., the dead load and that portion of the live load acting that may be considered as sustained and ϕN_n is determined as follow:

D.4.1.4.1 – For single anchors, $\phi N_n = 0.75\phi N_{a0}$

D.4.1.4.2 – For anchor groups, Eq. (D-1) shall be satisfied by taking $\phi N_n = 0.75\phi N_{a0}$ for that anchor in an anchor group that resists the highest tension load.

D.4.1.4.3 – where shear loads act concurrently with the sustained tension load, interaction of tension and shear shall be analyzed in accordance with D.4.1.3.

2006 IBC: D.5.2.9; 2009 IBC: D.5.2.10 - The limiting concrete strength of adhesive anchors in tension shall be calculated in accordance with D.5.2.1 to D.5.2.9 under the 2009 IBC or D.5.2.1 to D.5.2.8 under the 2006 IBC where the value of k to be used in Eq. (D-7) shall be

$k = 17$ where analysis indicates cracking at service-load levels in the anchor vicinity (cracked concrete)

$k = 24$ where analysis indicates no cracking ($f_t < f_r$) at service-load levels in the anchor vicinity (uncracked concrete)

The value of k shall be permitted to be increased to $k = 24$ (cracked concrete) and $k = 30$ (uncracked concrete) based on the results of tests in accordance with AC308.

D.5.3.7 - The nominal strength of an adhesive anchor N_a or group of adhesive anchors N_{ag} in tension shall not exceed

(a) for a single anchor

$$N_a = \frac{A_{Na}}{A_{Na0}} \Psi_{ed,Na} \Psi_{p,Na} N_{a0} \quad (D-16a)$$

(b) for a group of anchors

$$N_{ag} = \frac{A_{Na}}{A_{Na0}} \Psi_{ed,Na} \Psi_{g,Na} \Psi_{ec,Na} \Psi_{p,Na} N_{a0} \quad (D-16b)$$

where

A_{Na} is the projected area of the failure surface for the anchor or group of anchors that shall be approximated as the base of the rectilinear geometrical figure that results from projecting the failure surface outward a distance $c_{cr,Na}$ from the center line of the single anchor, or in the case of a group of anchors, from a line through a row of adjacent anchors. A_{Na} shall not exceed nA_{Na0} where n is the number of anchors in tension in the group. (Refer to ACI 318 Figures RD.5.2.1(a) and RD.5.2.1(b) and replace the terms $1.5h_{ef}$ and $3.0h_{ef}$ with $c_{cr,Na}$ and $s_{cr,Na}$, respectively.)

A_{Na0} is the projected area of the failure surface of a single anchor without the influence of proximate edges in accordance with Eq. (D-16c):

$$A_{Na0} = (s_{cr,Na})^2 \quad (D-16c)$$

with

$s_{cr,Na}$ = as given by Eq. (D-16d)

D.5.3.8 - The critical spacing $s_{cr,Na}$ and critical edge distance $c_{cr,Na}$ shall be calculated as follows:

$$s_{cr,Na} = 20 \cdot d \cdot \sqrt{\frac{\tau_{k,uncr}}{1,450}} \leq 3 \cdot h_{ef} \quad (D-16d)$$

$$c_{cr,Na} = \frac{s_{cr,Na}}{2} \quad (D-16e)$$

D.5.3.9 - The basic strength of a single adhesive anchor in tension in cracked concrete shall not exceed

$$N_{a0} = \tau_{k,cr} \cdot \pi \cdot d \cdot h_{ef} \quad (D-16f)$$

ICC-ES AC308 Strength Design Method for Adhesive Anchors

Continued from previous page.

D.5.3.10 - The modification factor for the influence of the failure surface of a group of adhesive anchors is

$$\Psi_{g,Na} = \Psi_{g,Na0} + \left[\left(\frac{s}{s_{cr,Na}} \right)^{0.5} (1 - \Psi_{g,Na0}) \right] \quad (D-16g)$$

where

$$\Psi_{g,Na0} = \sqrt{n} - \left[(\sqrt{n} - 1) \left(\frac{\tau_{k,cr}}{\tau_{k,max,cr}} \right)^{1.5} \right] \geq 1.0 \quad (D-16h)$$

n is the number of tension loaded adhesive anchors in a group

$\tau_{k,cr}$ is the characteristic bond strength in cracked concrete having strength f'_c evaluated from tests per AC308.

$$\tau_{k,max,cr} = \frac{k_{c,cr}}{\pi \cdot d} \sqrt{h_{ef} \cdot f'_c} \quad (D-16i)$$

$$k_{c,cr} = 17$$

whereby the value of $k_{c,cr}$ shall be permitted to be increased to a maximum value based on the results of tests in cracked concrete in accordance with AC308

D.5.3.11 - The modification factor for eccentrically loaded adhesive anchor groups is

$$\Psi_{ec,Na} = \frac{1}{1 + \frac{2e'N}{s_{cr,Na}}} \leq 1.0 \quad (D-16j)$$

Eq. (D-16j) is valid for $e'_N \leq \frac{s}{2}$

If the loading on an anchor group is such that only some anchors are in tension, only those anchors that are in tension shall be considered when determining the eccentricity e'_N for use in Eq. (D-16j).

In the case where eccentric loading exists about two orthogonal axes, the modification factor $\Psi_{ec,Na}$ shall be computed for each axis individually and the product of these factors used as $\Psi_{ec,Na}$ in Eq. (D-16b).

D.5.3.12 - The modification factor for edge effects for single adhesive anchors or anchor groups loaded in tension is

$$\Psi_{ed,Na} = 1.0 \text{ when } c_{a,min} \geq c_{cr,Na} \quad (D-16l)$$

$$\Psi_{ed,Na} = \left(0.7 + 0.3 \frac{c_{a,min}}{c_{cr,Na}} \right) \leq 1.0 \text{ when } c_{a,min} < c_{cr,Na} \quad (D-16m)$$

D.5.3.13 - When an adhesive anchor or a group of adhesive anchors is located in a region of a concrete member where analysis indicates no cracking at service load levels, the nominal strength N_a or N_{ag} of a single adhesive anchor or a group of adhesive anchors shall be calculated according to Eq. (D-16a) and Eq. (D-16b) with $\tau_{k,uncr}$ substituted for $\tau_{k,cr}$ in the calculation of the basic strength N_{a0} in accordance with Eq. (D-16f) $\tau_{k,uncr}$ shall be established based on tests in accordance with AC308. The factor $\Psi_{g,Na0}$ shall be calculated in accordance with Eq. (D-16h) whereby the value of $\tau_{k,max,uncr}$ shall be calculated in accordance with Eq. (D-16n) and substituted for $\tau_{k,max,cr}$ in Eq. (D-16h)

$$\tau_{k,max,uncr} = \frac{k_{c,uncr}}{\pi \cdot d} \sqrt{h_{ef} \cdot f'_c} \quad (D-16n)$$

D.5.3.14 - When an adhesive anchor or a group of adhesive anchors is located in a region of a concrete member where analysis indicates no cracking at service load levels, the modification factor $\Psi_{p,Na}$ shall be taken as

$$\Psi_{p,Na} = 1.0 \text{ when } c_{a,min} \geq c_{ac} \quad (D-16o)$$

$$\Psi_{p,Na} = \max \left\{ \frac{c_{a,min}; c_{cr,Na}}{c_{ac}} \right\} \text{ when } c_{a,min} < c_{ac} \quad (D-16p)$$

where

c_{ac} shall be determined by testing in accordance with AC308.

For all other cases $\Psi_{p,Na} = 1.0$.

D.6.3.2 - The nominal pryout strength of an adhesive anchor V_{cp} or group of adhesive anchors V_{cpg} shall not exceed

(a) for a single adhesive anchor

$$V_{cp} = \min \left\{ k_{cp} \cdot N_a; k_{cp} \cdot N_{cb} \right\} \quad (D-30a)$$

(b) for a group of adhesive anchors

$$V_{cpg} = \min \left\{ k_{cp} \cdot N_{ag}; k_{cp} \cdot N_{cbg} \right\} \quad (D-30b)$$

where

$$k_{cp} = 1.0 \text{ for } h_{ef} < 2.5 \text{ in.}$$

$$k_{cp} = 2.0 \text{ for } h_{ef} \geq 2.5 \text{ in.}$$

N_a is calculated in accordance with Eq. (D-16a)

N_{ag} is calculated in accordance with Eq. (D-16b)

N_{cb}, N_{cbg} are determined in accordance with D.5.2.9

D.8.8 - For adhesive anchors that will remain untorqued, the minimum edge distance shall be based on minimum cover requirements for reinforcement in 7.7. For adhesive anchors that will be torqued, the minimum edge distance and spacing shall be taken as $6d_o$ and $5d_o$, respectively, unless otherwise determined in accordance with AC308.

NOTE: Bond strength determination: Bond strength values are a function of the special-inspection level provided and installation conditions. Bond strength values must be modified with the factor K_{sat} for cases where the holes are drilled in water-saturated concrete as follows:

Special Inspection Level	Permissible Installation Condition	Bond Strength	Associated Strength Reduction Factor
Continuous	Dry Concrete	τ_k	$\Phi_{dry,ci}$
Continuous	Water-saturated	$\tau_k \times K_{sat,ci}$	$\Phi_{sat,ci}$
Periodic	Dry Concrete	τ_k	$\Phi_{dry,pi}$
Periodic	Water-saturated	$\tau_k \times K_{sat,pi}$	$\Phi_{sat,pi}$

Where applicable, the modified bond strengths must be used in lieu of $\tau_{k,cr}$ or $\tau_{k,uncr}$ in AC308 Equations (D-16a) and (D-16b). The resulting nominal bond strength must be multiplied by the strength-reduction factor for the special-inspection level listed above. The various factors are given in Tables 5A and 5B of ESR-2508 and page 17 and 18 of this catalog.

Treatment of Design Methods *Under Model Building Codes*

Structural Post-Installed Anchor Design Methods Permitted by Building Codes

Building Code	Base Material	Permitted Design Methods ³		
		Traditional ASD	ACI 318 App. D/ ICC-ES AC193	ICC-ES AC308
2009 IBC/IRC	Concrete ¹	No	Yes	Yes
	Masonry ²	Yes	N/A ⁴	N/A ⁴
2006 IBC/IRC	Concrete ¹	No	Yes	Yes
	Masonry ²	Yes	N/A ⁴	N/A ⁴
2003 IBC/IRC	Concrete ¹	No	Yes	Yes
	Masonry ²	Yes	N/A ⁴	N/A ⁴
2000 IBC/IRC	Concrete ¹	Yes	Yes	Yes
	Masonry ²	Yes	N/A ⁴	N/A ⁴

1. "Concrete" includes all concrete base materials such as concrete on metal deck and precast concrete shapes.

2. "Masonry" includes all masonry base materials such as hollow and grout-filled CMU and unreinforced brick masonry.

3. Code interpretations vary. Confirm with the local Building Official.

4. Not applicable since masonry is beyond the scope of this design method.

Building codes and material standards have traditionally allowed Designers to take a one third allowable-stress increase on the calculated design capacities of some building materials and components when designing for forces generated from wind and/or seismic events. Newer codes and standards only allow the allowable stress increase to be taken when using an alternate set of load combinations. The table below summarizes when allowable-stress increases are permitted.

1/3 Allowable-Stress Increase for Structural Post-Installed Anchors

Building Code	Base Material	Is 1/3 Allowable Stress Increase Permitted for Post-Installed Anchors Designed with Traditional ASD?
2009 IBC/IRC	Concrete ¹	N/A ³
	Masonry ²	Yes ⁴
2006 IBC/IRC	Concrete ¹	N/A ³
	Masonry ²	Yes ⁴
2003 IBC/IRC	Concrete ¹	N/A ³
	Masonry ²	Yes ⁴
2000 IBC/IRC	Concrete ¹	Yes ⁴
	Masonry ²	Yes ⁴

1. "Concrete" includes all concrete base materials such as reinforced concrete, concrete on metal deck and precast concrete shapes.

2. "Masonry" includes all masonry base materials such as hollow and grout-filled CMU and unreinforced clay-brick masonry.

3. Not applicable since this code does not use traditional ASD for post-installed anchors.

4. Only when indicated in the applicable load table in this catalog and when alternative basic load combinations as prescribed in the code are used.

Treatment of Design Methods *Under Model Building Codes*

Structural Post-Installed Anchor Selection Guide

Adhesive Anchors	Design Methods Covered		Base Materials Covered							Code Listings ²
	Traditional ASD ¹	ICC-ES AC308	Concrete		Conc. over Mtl. Deck		CMU		URM ⁴	
	ASD	(SD & ASD)	Uncracked	Cracked	Uncracked	Cracked	Grout-Filled	Hollow		
SET-XP™		X	X	X	X ³	X ³				ICC-ES
SET	X		X		X ³		X	X	X	ICC-ES
ET-HP	X	X	X		X ³		X	X	X	ICC-ES
AT	X		X		X ³		X	X	X	ICC-ES
VGC	X		X		X ³					
EDOT™	X		X							

- Allowable loads for traditional ASD are derived from applicable test methods such as ASTM E488, ASTM E1512 and legacy ICC-ES acceptance criteria AC58 and AC60.
- Code listings may not be available for all products/applications cited in the table. To verify code listed products/applications refer to "code reports" at www.strongtie.com or contact Simpson Strong-Tie at (800) 999-5099 (U.S. and Canada).
- Installed into top surface.
- Unreinforced clay brick masonry.

Mechanical Anchors	Design Methods Covered		Base Materials Covered						Code Listings ²
	Traditional ASD ¹	ACI 318 App. D/ ICC-ES AC193	Concrete		Conc. over Mtl. Deck		CMU		
	ASD	(SD & ASD)	Uncracked	Cracked	Uncracked	Cracked	Grout-Filled	Hollow	
Torq-Cut™		X	X	X					ICC-ES Pending
Strong-Bolt™		X	X	X					ICC-ES
Strong-Bolt™ 2		X	X	X	X	X	X		ICC-ES
Titen HD®	X	X	X	X	X	X	X	X	ICC-ES
Wedge-All®	X		X		X		X		ICC-ES
Sleeve-All™	X		X				X		
Drop-In™	X		X		X				
Blue Banger Hanger®	X		X		X				
Easy-Set	X		X						
Titen® Screw	X		X				X	X	

- Allowable loads for traditional ASD are derived from applicable test methods such as ASTM E488, ASTM E1512 and legacy ICC-ES acceptance criteria AC01, AC70, and AC106.
- Code listings may not be available for all products/applications cited in the table. To verify code listed products/applications refer to "code reports" at www.strongtie.com or contact Simpson Strong-Tie at (800) 999-5099 (U.S. and Canada).

Example Calculation Adhesive Anchors (Traditional ASD)

Example calculation for a grouping of adhesive anchors using ASD:

Design a connection comprised of four ¾" diameter all-thread rods installed in $f'_c = 2,000$ psi concrete using SET adhesive as shown. The anchor grouping is subject to an applied tension load of 3,000 lb. and an applied shear load of 1,000 lb. acting simultaneously.

ADDITIONAL DATA:

- All-thread rod material: ASTM A1554 Grade 36.
- All-thread rod embedment depth: 6¾"
- All-thread rod spacing: $S1=S3=8"$, $S2=11.3"$ (use 11")
($S_{critical} = 27" > S_{actual}$, therefore reduced efficiency.)
- All-thread rod edge distance: $C1=C2=3"$
($C_{critical} = 10\frac{1}{8}" > C_{actual}$, therefore reduced efficiency.)

SOLUTION:

Unadjusted allowable tension loads:

Based on adhesive bond strength = $T_{bond} = 10,525$ lbs.

Based on steel strength = $T_{steel} = 8,460$ lbs.

Unadjusted allowable shear loads:

Based on concrete strength = $V_{conc} = 6,310$ lbs.

Based on steel strength = $V_{steel} = 4,360$ lbs.

Calculate reduced efficiency factors for all-thread rod installed at an edge distance of 3" using tables on pages 48–49:

Tension: $C1=C2=3"$, $f_c = 0.56$ from f_c - Tension Table

Shear: $C1=C2=3"$, $f_c = 0.29$ from f_c - Shear Table

Calculate reduced efficiency factors for all-thread rod installed at a spacing of 8" using tables on pages 50–51:

Tension: $S1=S3=8"$, $f_s = 0.91$ from f_s - Tension Table

$S2=11"$, $f_s = 0.925$ from f_s - Tension Table

Shear: $S1=S3=8"$, $f_s = 0.95$ from f_s - Shear Table

$S2=11"$, $f_s = 1.00$ from f_s - Shear Table

Reduce allowable tension value based on bond strength. The reduction factors are cumulative due to the influence of two reduced edge distance conditions and three reduced spacing conditions:

$$\begin{aligned} (T_{bond})_{net} &= (f_c)(f_s)(T_{bond}) \\ &= (0.56 \times 0.56)(0.91 \times 0.91 \times 0.925)(10,525 \text{ lbs.}) \\ &= 2,528 \text{ lbs.} \end{aligned}$$

Allowable tension value is the lesser of:

Tension based on net bond strength = **2,528 lbs.** (governs) or

Tension based on steel strength = 8,460 lbs.

For a group of 4 anchors the combined allowable tension value is:

$$= (4 \text{ anchors})(2,528 \text{ lbs./anchor}) = \mathbf{10,112 \text{ lbs.} > 3,000 \text{ lbs.}}$$

(design tension) O.K.

(Note: If high in-service temperature is expected, the allowable based on bond/concrete should be multiplied by a strength reduction factor found in the adhesive's temperature sensitivity table.)

Reduce allowable shear value based on concrete strength. The reduction factors are cumulative due to the influence of two reduced edge-distance conditions and three reduced spacing conditions:

$$\begin{aligned} (V_{conc})_{net} &= (f_c)(f_s)(V_{conc}) \\ &= (0.29 \times 0.29)(.95 \times .95 \times 1.00)(6,310 \text{ lbs.}) \\ &= 478 \text{ lbs.} \end{aligned}$$

Allowable shear value is the lesser of:

Shear based on net concrete strength = **478 lbs.** (governs) or

Shear based on steel strength = 4,360 lbs.

For a group of 4 anchors the combined allowable shear value is:

$$= (4 \text{ anchors})(478 \text{ lbs./anchor}) = \mathbf{1,912 \text{ lbs.} > 1,000 \text{ lbs.}}$$

(design shear) O.K.

(Note: If high in-service temperature is expected, the allowable shear based on bond/concrete should be multiplied by a strength reduction factor found in the adhesive's temperature sensitivity table.)

Four Anchor Layout

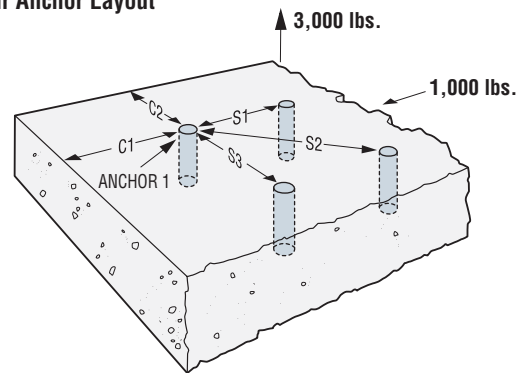

The allowable tension (or shear) value for a group of anchors is equal to the lowest (minimum) tension (or shear) value for a single anchor within the group multiplied by the number of anchors within the group.

CHECK COMBINED TENSION AND SHEAR INTERACTION:

For adhesive anchors, use the straight-line method ($n=1.0$, see Figure 1) when calculating the interaction of both tension and shear upon the anchor per the following equation:

$$(\text{Design shear/allowable shear})^n + (\text{Design tension/allowable tension})^n \leq 1.0, n=1.0$$

Design shear (V) = 1,000 lbs.

Allowable shear (V_{all}) = 1,912 lbs.

Design tension (T) = 3,000 lbs.

Allowable tension (T_{all}) = 10,112 lbs.

$$(1,000/1,912)^{1.0} + (3,000/10,112)^{1.0} = 0.82 \leq 1.0 \text{ O.K.}$$

Figure 1

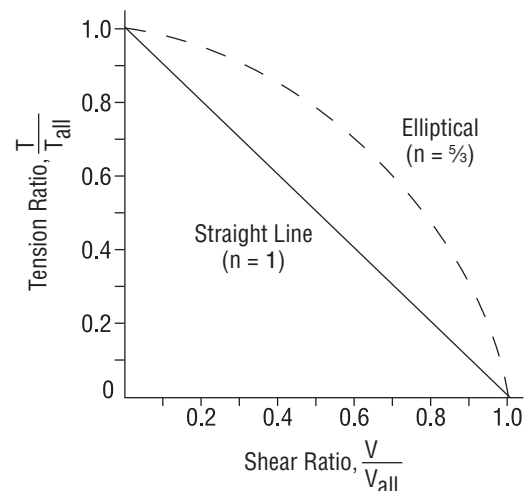

Example Calculation Mechanical Anchors (Traditional ASD)

Example calculation for a group of (2) Titen HD® anchors using ASD:

Design a connection comprised of two (2) ¾" diameter Titen HD® anchors installed in the face of an 8" normal weight grouted CMU wall as shown. The anchor group has an applied tension load of 600 lbs. and an applied shear load of 500 lbs. acting simultaneously.

ADDITIONAL DATA:

- Embedment depth = 5 ½"
- Spacing = $S_{act} = S1 = 8"$.
- Critical spacing for ¾" dia. anchor at embedment = $S_{Cr} = 12"$.
- $S_{act} < S_{Cr}$ therefore use spacing reduction factor for S1.
- End distance = $C_{act} = C1 = 4"$
Edge distance = $C_{act} = C2 = 12"$
- Critical edge distance = $C_{Cr} = 12"$.
- Critical end distance = $C_{Cr} = 12"$.
- $C1 < C_{Cr}$, therefore use perpendicular-to-edge reduction factor for C1.
- $C2 > C_{Cr}$, therefore no edge reduction factor for C2.

SOLUTION:

TENSION

Determine uninfluenced allowable tension load in the face of an 8" normal wt. concrete grouted CMU wall:

Uninfluenced allowable tension = 1,600 lbs.

Calculate reduced efficiency factors for Edge Distance:

$$C_{act} = C1 = 4"$$

$$C_{act} = C2 = 12"$$

$$f_{cC1} = 0.66 = \text{Load adjustment factor (page 130)}$$

Calculate reduced efficiency factor for spacing:

$$S_{act} = S1 = 8"$$

$$f_{sS1} = 0.67 = \text{Load adjustment factor (page 130)}$$

Calculate allowable tension load per anchor:

$$\text{Allowable tension} = (\text{uninfluenced allowable tension}) (f_{cC1})(f_{sS1})$$

$$\text{Allowable tension} = (1,600 \text{ lbs.})(0.66)(0.67) = 708 \text{ lbs. per anchor}$$

For a group of 2 anchors the combined allowable tension value is:

$$= (2 \text{ anchors})(708 \text{ lbs./anchor}) = \mathbf{1,416 \text{ lbs.} > 600 \text{ lbs.}}$$

(design tension) O.K.

SHEAR

Determine uninfluenced allowable shear load in the face of an 8" normal wt. concrete grouted CMU wall:

Uninfluenced allowable shear = 3,000 lbs.

Calculate reduced efficiency factor for end distance:

$$C_{act} = C1 = 4"$$

$$C_{act} = C2 = 12"$$

$$f_{cC1} = 0.21 = \text{Load adjustment factor (page 130)}$$

Calculate reduced efficiency factor for spacing:

$$S_{act} = S1 = 8"$$

$$f_{sS1} = 0.75 = \text{Load adjustment factor (page 130)}$$

Calculate allowable shear load per anchor:

$$\text{Allowable shear} = (\text{uninfluenced allowable shear}) (f_{cC1})(f_{sS1})$$

$$\text{Allowable shear} = (3,000 \text{ lbs.})(0.21)(0.75) = 473 \text{ lbs. per anchor}$$

For a group of 2 anchors the combined allowable shear value is:

$$= (2 \text{ anchors})(473 \text{ lbs./anchor}) = \mathbf{945 \text{ lbs.} > 500 \text{ lbs.}}$$

(design shear) O.K.

Two Anchor Layout

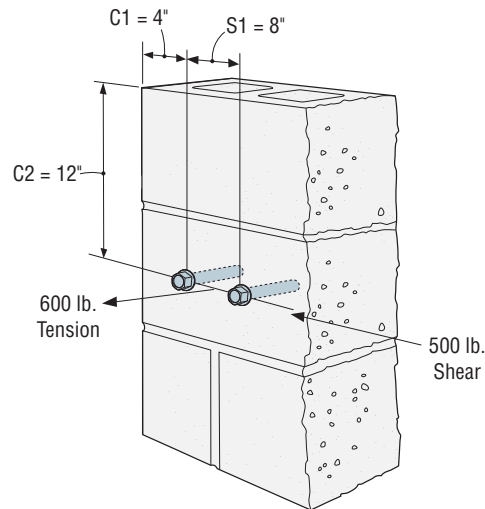

The allowable tension (or shear) value for a group of anchors is equal to the lowest (minimum) tension (or shear) value for a single anchor within the group multiplied by the number of anchors within the group.

CHECK COMBINED TENSION AND SHEAR INTERACTION:

For the Titen HD® in grouted CMU, use the straight-line method ($n = 1$, see Figure 1) when calculating the interaction of both tension and shear upon the anchor per the following equation:

$$(\text{Design shear/Allowable shear})^n + (\text{Design tension/Allowable tension})^n \leq 1.0, n = 1$$

Design shear (V) = 500 lbs.

Allowable shear (V_{all}) = 945 lbs.

Design tension (T) = 600 lbs.

Allowable tension (T_{all}) = 1,416 lbs.

$$(600/1,416)^1 + (500/945)^1 = 0.95 \leq 1.0 \text{ O.K.}$$

Figure 1

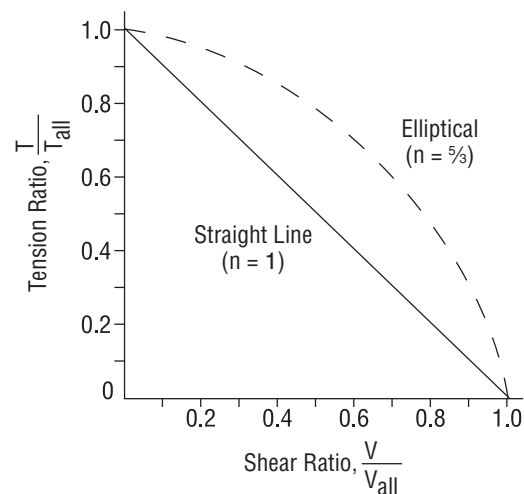

Note: The elliptical method permits greater allowable tension and shear loads to be used than the straight-line method.

Example Calculation Mechanical Anchors (ACI 318 App. D/ICC-ES AC193)

Example calculation for a single Strong-Bolt™ 2 anchor using SD:

Determine if a single ½" diameter carbon-steel Strong-Bolt™ 2 torque-controlled expansion anchor with a minimum 3⅞" embedment ($h_{ef} = 3\frac{7}{8}$ inches) installed 4" from the edge of a 12" deep spandrel beam is adequate for a service tension load of 1,000 lb. for wind and a reversible service shear load of 350 lb. for wind. The anchor will be in the tension zone, away from other anchors in $f'_c = 3,000$ psi normal-weight concrete.

Reference the appropriate tables in this catalog for Strong-Bolt 2 anchor performance values as determined from testing in accordance with ACI 355.2 and ICC-ES AC193.

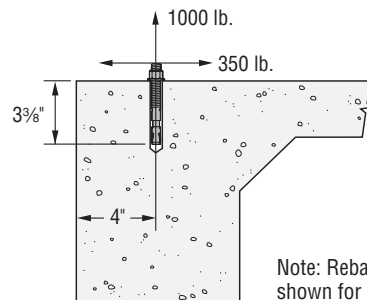

Note: Rebar not shown for clarity.

CALCULATIONS AND DISCUSSION

REFERENCE

Note: Calculations are performed in accordance with ACI 318-08.

1. Determine the factored tension and shear design loads:

ACI 318, 9.2.1

$$N_{ua} = 1.6W = 1.6 \times 1,000 = 1,600 \text{ lb.}$$

$$V_{ua} = 1.6W = 1.6 \times 350 = 560 \text{ lb.}$$

2. Design considerations:

D.4.1.2

This is a combined tension and shear interaction problem where values for both ϕN_n and ϕV_n need to be determined. ϕN_n is the lesser of the design tension strength controlled by: steel (ϕN_{sa}), concrete breakout (ϕN_{cb}), or pull-out ($\phi n N_{pn}$). ϕV_n is the lesser of the design shear strength controlled by: steel (ϕV_{sa}), concrete breakout (ϕV_{cb}), or pryout (ϕV_{cp}).

3. Steel capacity under tension Loading:

D.5.1

$$\phi N_{sa} \geq N_{ua}$$

Eq. (D-1)

$$N_{sa} = 12,100 \text{ lb.}$$

This catalog

$$\phi = 0.75$$

This catalog

$$n = 1 \text{ (single anchor)}$$

Calculating for ϕN_{sa} :

$$\phi N_{sa} = 0.75 \times 1 \times 12,100 = 9,075 \text{ lb.} > 1,600 \text{ lb.} - \text{OK}$$

CALCULATIONS AND DISCUSSION

REFERENCE

4. Concrete breakout capacity under tension loading:

D.5.2

$$\phi N_{cb} \geq N_{ua}$$

Eq. (D-1)

$$N_{cb} = \frac{A_{Nc}}{A_{Nco}} \Psi_{ed,N} \Psi_{c,N} \Psi_{cp,N} N_b$$

Eq. (D-4);

where:

$$N_b = k_C \lambda \sqrt{f'_c} h_{ef}^{1.5}$$

Eq. (D-7)

substituting:

$$\phi N_{cb} = \phi \frac{A_{Nc}}{A_{Nco}} \Psi_{ed,N} \Psi_{c,N} \Psi_{cp,N} k_C \lambda \sqrt{f'_c} h_{ef}^{1.5}$$

where:

$$k_C = k_{Cr} = 17$$

This catalog

(Anchor is installed in a tension zone, therefore, cracking is assumed at service loads)

$$\lambda = 1.0 \text{ for normal-weight concrete}$$

8.6.1

$$\Psi_{cp,N} = 1.0$$

D.5.2.7

$$\Psi_{ed,N} = 0.7 + 0.3 \frac{c_{a,min}}{1.5 h_{ef}} \text{ when } c_{a,min} < 1.5 h_{ef}$$

Eq. (D-11)

by observation, $c_{a,min} = 4 < 1.5 h_{ef}$

$$\Psi_{ed,N} = 0.7 + 0.3 \frac{(4)}{1.5(3.375)} = 0.94$$

$\Psi_{c,N} = 1.0$ assuming cracking at service loads ($f_t > f_r$)

D.5.2.6

$\phi = 0.65$ for Condition B

This catalog

(no supplementary reinforcement provided)

$$A_{Nco} = 9 h_{ef}^2 = 9(3.375)^2 = 102.52 \text{ in.}^2$$

Eq. (D-6)

$$A_{Nc} = (c_{a1} + 1.5 h_{ef})(2 \times 1.5 h_{ef}) = (4 + 1.5(3.375))(2 \times 1.5(3.375)) = 91.76 \text{ in.}^2$$

Fig. RD.5.2.1(a)

$$\frac{A_{Nc}}{A_{Nco}} = \frac{91.76}{102.52} = 0.90$$

Calculating for ϕN_{cb} :

$$\phi N_{cb} = 0.65 \times 0.90 \times 0.94 \times 1.0 \times 1.0 \times 17 \times 1.0 \times$$

$$\sqrt{3,000} \times (3.375)^{1.5} = 3,175 \text{ lb.} > 1,600 \text{ lb.} - \text{OK}$$

Would you like help with these calculations?
Visit www.strongtie.com to download the
Simpson Strong-Tie® Anchor Selector™ software.



Example Calculation *Mechanical Anchors (ACI 318 App. D/ICC-ES AC193)*

Continued from previous page.

CALCULATIONS AND DISCUSSION	REFERENCE	CALCULATIONS AND DISCUSSION	REFERENCE
5. Pullout capacity:	D.5.3	9. Concrete pryout strength:	D.6.3
Pullout capacity, $N_{p,cr}$, is established by reference tests in cracked concrete by the reliability test of ACI 355.2. Data from the anchor prequalification testing must be used. Reference Strong-Bolt® 2 anchor "characteristic tension design values" table for the 5 percent fractile value, $N_{p,cr}$.		$\phi n V_{cp} \geq V_{ua}$	Eq. (D-2)
$\phi N_{pn} \geq N_{ua}$	Eq. (D-1)	$V_{cp} = k_{cp} N_{cb}$	Eq. (D-29)
$N_{p,cr} = 3,735 \times \left(\frac{3,000}{2,500}\right)^{0.5} = 4,091$ lb.	This catalog	where:	
$\phi = 0.65$	This catalog	$n = 1$	
$\phi N_{pn} = 0.65 \times 4,091 = 2,659$ lb. > 1,600 lb. – OK		$k_{cp} = 2.0$ and $\phi = 0.70$	This catalog
6. Check all failure modes under tension loading:	D.4.1.2	$k_{cp} N_{cb} = 2.0 \times \frac{3,175}{0.65} = 9,769$ lb.	D.6.3.1
Summary:		$\phi n V_{cp} = 0.70 \times 1 \times 9,769 = 6,838$ lb. > 560 lb. – OK	
Steel capacity = 9,075 lb.			
Concrete breakout capacity = 3,175 lb.		10. Check all failure modes under shear Loading:	D.4.1.2
Pullout capacity = 2,659 lb. ← Controls		Summary:	
∴ $\phi N_n = 2,659$ lb. as pullout capacity controls		Steel capacity = 4,703 lb.	
7. Steel capacity under shear loading:	D.6.1	Concrete breakout capacity = 2,224 lb. ← Controls	
$\phi V_{sa} \geq V_{ua}$	Eq. (D-2)	Pryout capacity = 6,838 lb.	
$V_{sa} = 7,235$ lb.	This catalog	∴ $\phi V_n = 2,224$ lb. as concrete breakout capacity controls	
$\phi = 0.65$	This catalog		
Calculating for ϕV_{sa} :		11. Check interaction of tension and shear forces:	D.7
$\phi V_{sa} = 0.65 \times 7,235 = 4,703$ lb. > 560 lb. – OK		If $0.2 \phi V_n \geq V_{ua}$, then the full tension design strength is permitted.	D.7.1
8. Concrete breakout capacity under shear loading:	D.6.2	By observation, this is not the case.	
$\phi V_{cb} \geq V_{ua}$	Eq. (D-2)	If $0.2 \phi N_n \geq N_{ua}$, then the full shear design strength is permitted	D.7.2
$V_{cb} = \frac{A_{VC}}{A_{VCO}} \Psi_{ed,V} \Psi_{c,V} \Psi_{h,V} V_b$	Eq. (D-21)	By observation, this is not the case.	
where:		Therefore:	
$V_b = 7 \left(\frac{\ell_e}{d_a}\right)^{0.2} \sqrt{d_a} \lambda \sqrt{f'_c} C_{a1}^{1.5}$	Eq. (D-24)	$\frac{N_{ua}}{\phi N_n} + \frac{V_{ua}}{\phi V_n} \leq 1.2$	Eq. (D-31)
substituting:		$\frac{1,600}{2,659} + \frac{560}{2,224} = 0.60 + 0.25 = 0.85 < 1.2$ – OK	
$\phi V_{cb} = \phi \frac{A_{VC}}{A_{VCO}} \Psi_{ed,V} \Psi_{c,V} \Psi_{h,V} 7 \left(\frac{\ell_e}{d_a}\right)^{0.2} \sqrt{d_a} \lambda \sqrt{f'_c} C_{a1}^{1.5}$		12. Summary	
where:		A single ½" diameter carbon-steel Strong-Bolt® 2 anchor at a 3¼" embedment depth is adequate to resist the applied service tension and shear loads of 1,000 lb. and 350 lb., respectively.	
$\phi = 0.70$ for Condition B (no supplementary reinforcement provided)	D.4.4(c)(i)		
$A_{VCO} = 4.5 C_{a1}^2$ $= 4.5(4)^2$ ∴ $A_{VCO} = 72$ in. ²	Eq. (D-23)		
$A_{VC} = 2(1.5 C_{a1})(1.5 C_{a1})$ $= 2(1.5(4))(1.5(4))$ ∴ $A_{VC} = 72$ in. ²	Fig. RD.6.2.1(a)		
$\frac{A_{VC}}{A_{VCO}} = \frac{72}{72} = 1$	D.6.2.1		
$h_a = 12$ in.			
$\Psi_{h,V} = 1.0$ since $h_a > 1.5 C_{a1}$	D.6.2.8		
$\Psi_{ed,V} = 1.0$ since $C_{a2} > 1.5 C_{a1}$	Eq. (D-27)		
$\Psi_{c,V} = 1.0$ assuming cracking at service loads ($f_t > f_r$)	D.6.2.7		
$d_a = 0.5$ in.			
$\ell_e = 3.375$ in.	D.6.2.2		
$\lambda = 1.0$ for normal-weight concrete	8.6.1		
$C_{a1} = 4$ in.			
$\phi V_{cb} = 0.70 \times 1 \times 1.0 \times 1.0 \times 1.0 \times 7 \times \left(\frac{3.375}{0.5}\right)^{0.2} \times \sqrt{0.5} \times 1.0$ $\times \sqrt{3,000} \times (4)^{1.5} = 2,224$ lb. > 560 lb. – OK			

Example Calculation Adhesive Anchors (ICC-ES AC308)

Example calculation for a single SET-XP™ epoxy adhesive anchor using USD:

Determine if a single ½" diameter ASTM A193 Grade B7 anchor rod in SET-XP™ epoxy adhesive anchor with a minimum 4½" embedment ($h_{ef} = 4\frac{1}{2}"$) installed 1¾" from the edge of a 12" deep spandrel beam is adequate for a service tension load of 650 lb. for wind and a reversible service shear load of 275 lb. for wind. The anchor will be in the tension zone, away from other anchors in $f'_c = 3,000$ psi normal-weight concrete (dry). The anchor will be subjected to a maximum short-term temperature of 110°F and a maximum long-term temperature of 75°F. Continuous inspection will be provided

Reference the appropriate tables in this catalog for SET-XP epoxy adhesive anchor performance values as determined from testing in accordance with ICC-ES AC308.

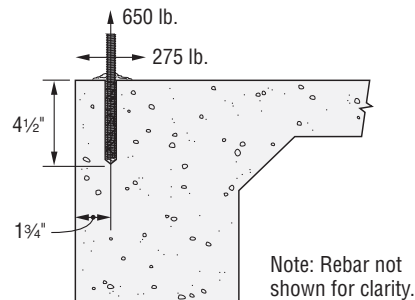

CALCULATIONS AND DISCUSSION

REFERENCE

Note: Calculations are performed in accordance with ICC-ES AC308 and ACI 318-08.

1. Determine the factored tension and shear design loads:

ACI 318, 9.2.1

$$N_{ua} = 1.6W = 1.6 \times 650 = 1,040 \text{ lb.}$$

$$V_{ua} = 1.6W = 1.6 \times 275 = 440 \text{ lb.}$$

2. Design considerations:

D.4.1.2

This is a combined tension and shear interaction problem where values for both ϕN_n and ϕV_n need to be determined. ϕN_n is the lesser of the design tension strength controlled by: steel (ϕN_{sa}), concrete breakout (ϕN_{cb}), or adhesive (ϕN_a). ϕV_n is the lesser of the design shear strength controlled by: steel (ϕV_{sa}), concrete breakout (ϕV_{cb}), or pryout (ϕV_{cp}).

3. Steel capacity under tension loading:

D.5.1

$$\phi N_{sa} \geq N_{ua}$$

Eq. (D-1)

$$N_{sa} = 17,750 \text{ lb.}$$

This catalog

$$\phi = 0.75$$

This catalog

$$n = 1 \text{ (single anchor)}$$

Calculating for ϕN_{sa} :

$$\phi N_{sa} = 0.75 \times 1 \times 17,750 = 13,313 \text{ lb.} > 1,040 \text{ lb.} - \text{OK}$$

CALCULATIONS AND DISCUSSION

REFERENCE

4. Concrete breakout capacity under tension loading:

D.5.2

$$\phi N_{cb} \geq N_{ua}$$

Eq. (D-1)

$$N_{cb} = \frac{A_{nc}}{A_{nco}} \Psi_{ed,N} \Psi_{c,N} \Psi_{cp,N} N_b$$

Eq. (D-4);

where:

$$N_b = k_c \lambda \sqrt{f'_c} h_{ef}^{1.5}$$

Eq. (D-7)

substituting:

$$\phi N_{cb} = \phi \frac{A_{nc}}{A_{nco}} \Psi_{ed,N} \Psi_{c,N} \Psi_{cp,N} k_c \lambda \sqrt{f'_c} h_{ef}^{1.5}$$

where:

$$k_c = k_{cr} = 17$$

This catalog

$$\lambda = 1.0 \text{ for normal-weight concrete}$$

8.6.1

$$\Psi_{cp,N} = 1.0$$

D.5.2.7

$$\Psi_{ed,N} = 0.7 + 0.3 \frac{c_{a,min}}{1.5 h_{ef}} \text{ when } c_{a,min} < 1.5 h_{ef}$$

Eq. (D-11)

by observation, $c_{a,min} < 1.5 h_{ef}$

$$\Psi_{ed,N} = 0.7 + 0.3 \frac{1.75}{1.5(4.5)} = 0.78$$

$$\Psi_{c,N} = 1.0$$

D.5.2.6

$$\phi = 0.65 \text{ for Condition B}$$

This catalog

(no supplementary reinforcement provided)

$$\begin{aligned} A_{nco} &= 9h_{ef}^2 \\ &= 9(4.5)^2 \\ &= 182.25 \text{ in.}^2 \end{aligned}$$

Eq. (D-6)

$$\begin{aligned} A_{nc} &= (c_{a1} + 1.5h_{ef})(2 \times 1.5h_{ef}) \\ &= (1.75 + 1.5(4.5))(2 \times 1.5(4.5)) \\ &= 114.75 \text{ in.}^2 \end{aligned}$$

Fig. RD.5.2.1(a)

$$\frac{A_{nc}}{A_{nco}} = \frac{114.75}{182.25} = 0.63$$

$$f'_c = 2,500 \text{ psi}$$

ICC-ES ESR-2508 section 5.3

Calculating for ϕN_{cb} :

$$\phi N_{cb} = 0.65 \times 0.63 \times 1.0 \times 0.78 \times 1.0 \times 17 \times 1.0 \times$$

$$\sqrt{2,500} \times (4.5)^{1.5} = 2,592 \text{ lb.} > 1,040 \text{ lb.} - \text{OK}$$

Would you like help with these calculations?
Visit www.strongtie.com to download the
Simpson Strong-Tie® Anchor Selector™ software.



Example Calculation Adhesive Anchors (ICC-ES AC308)

Continued from previous page.

CALCULATIONS AND DISCUSSION

5. Adhesive anchor capacity under tension loading:

$$\phi N_a \geq N_{ua}$$

$$N_a = \frac{A_{Na}}{A_{Na0}} \psi_{ed,Na} \psi_{p,Na} N_{a0}$$

$$N_{a0} = \tau_{k,cr} \pi d h_{ef} = 995 \pi (0.5)(4.5) = 7,033 \text{ lb.}$$

$$s_{cr,Na} = 20d \sqrt{\frac{\tau_{k,uncr}}{1,450}} \leq 3h_{ef}$$

$$s_{cr,Na} = (20)(0.5) \sqrt{\frac{2,250}{1,450}} = 12.46" \leq 3h_{ef} = 13.5"$$

$$s_{cr,Na} = 12.46"$$

$$c_{cr,Na} = \frac{s_{cr,Na}}{2} = \frac{12.46}{2} = 6.23"$$

$$A_{Na0} = (s_{cr,Na})^2 = (12.46)^2 = 155.25 \text{ in}^2$$

$$A_{Na} = (c_{a1} + c_{cr,Na})(s_{cr,Na}) = (1.75 + 6.23)(12.46) = 99.43 \text{ in}^2$$

$$\psi_{ed,Na} = (0.7 + 0.3 \frac{c_{a,min}}{c_{cr,Na}}) \leq 1.0 \text{ Since } c_{a,min} < c_{cr,Na} \text{ Eq. (D-16m)}$$

$$\psi_{ed,Na} = (0.7 + 0.3 \frac{1.75}{6.23}) = (0.7 + 0.3 \frac{1.75}{6.23}) = 0.78$$

$$\psi_{p,Na} = 1.0$$

REFERENCE

AC308 Section 3.3

Eq. (D-1)

Eq. (D-16a)

Eq. (D-16f)

Eq. (D-16d)

Eq. (D-16e)

Eq. (D-16c)

Eq. (D-16m)

AC308 D.5.3.14

This catalog

Calculating for ϕN_a :

$$\phi N_a = 0.65 \times \frac{99.43}{155.25} \times 0.78 \times 1.0 \times 7,033 = 2,284 \text{ lb.} > 1,040 \text{ lb.} - \text{OK}$$

6. Check all failure modes under tension loading:

D.4.1.2

Summary:

Steel capacity = 13,313 lb.

Concrete breakout capacity = 2,592 lb. ← **Controls**

Adhesive capacity = 2,284 lb.

∴ $\phi N_n = 2,284 \text{ lb.}$ as concrete breakout capacity controls

7. Steel capacity under shear loading:

D.6.1

$$\phi V_{sa} \geq V_{ua}$$

$$V_{sa} = 10,650 \text{ lb.}$$

$$\phi = 0.65$$

Calculating for ϕV_{sa} :

$$\phi V_{sa} = 0.65 \times 10,650 = 6,923 \text{ lb.} > 440 \text{ lb.} - \text{OK}$$

Eq. (D-2)

This catalog

This catalog

CALCULATIONS AND DISCUSSION

8. Concrete breakout capacity under shear loading:

D.6.2

$$\phi V_{cb} \geq V_{ua}$$

Eq. (D-2)

$$V_{cb} = \frac{A_{VC}}{A_{VCO}} \psi_{ed,V} \psi_{c,V} \psi_{h,V} \psi_{v} V_b$$

Eq. (D-21)

where:

$$V_b = 7 \left(\frac{\ell_e}{d_a} \right)^{0.2} \sqrt{d_a} \lambda \sqrt{f'_c} c_{a1}^{1.5}$$

Eq. (D-24)

substituting:

$$\phi V_{cb} = \phi \frac{A_{VC}}{A_{VCO}} \psi_{ed,V} \psi_{c,V} \psi_{h,V} \psi_{v} 7 \left(\frac{\ell_e}{d_a} \right)^{0.2} \sqrt{d_a} \lambda \sqrt{f'_c} c_{a1}^{1.5}$$

where:

 $\phi = 0.70$ for Condition B

(no supplementary reinforcement provided)

D4.4(c)(i)

$$A_{VCO} = 4.5c_{a1}^2$$

$$= 4.5(1.75)^2$$

$$\therefore A_{VCO} = 13.78 \text{ in.}^2$$

Eq. (D-23)

$$A_{VC} = 2(1.5c_{a1})(1.5c_{a1})$$

$$= 2(1.5(1.75))(1.5(1.75))$$

$$\therefore A_{VC} = 13.78 \text{ in.}^2$$

Fig. RD.6.2.1(a)

$$\frac{A_{VC}}{A_{VCO}} = \frac{13.78}{13.78} = 1$$

D.6.2.1

$$h_a = 12 \text{ in.}$$

$$\psi_{h,V} = 1.0 \text{ since } h_a > 1.5 c_{a1}$$

D.6.2.8

$$\psi_{ed,V} = 1.0 \text{ since } c_{a2} > 1.5c_{a1}$$

Eq. (D-27)

$$\psi_{c,V} = 1.0 \text{ for cracked concrete}$$

D.6.2.7

$$d_a = 0.5 \text{ in.}$$

$$\ell_e = 8d_a = 8(0.5) = 4"$$

D.6.2.2

$$\lambda = 1.0 \text{ for normal-weight concrete}$$

8.6.1

$$c_{a1} = 1.75 \text{ in.}$$

$$\phi V_{cb} = 0.70 \times 1 \times 1.0 \times 1.0 \times 1.0 \times 7 \times \left(\frac{4}{0.5} \right)^{0.2} \times \sqrt{0.5} \times 1.0$$

$$\times \sqrt{3,000} \times (1.75)^{1.5} = 666 \text{ lb.} > 440 \text{ lb.} - \text{OK}$$

9. Concrete pryout capacity per AC308

$$V_{cp} = \min[k_{cp} N_a; k_{cp} N_{cb}]$$

Eq. (D-30a)

$$k_{cp} = 2.0 \text{ for } h_{ef} \geq 2.5"$$

$$N_a = 3,514 \text{ lb. from adhesive-capacity calculation without } \phi \text{ factor}$$

$$N_{cb} = 3,988 \text{ lb. from concrete-breakout calculation without } \phi \text{ factor}$$

$$V_{cp} = (2.0)(3,514) = 7,028 \text{ lb. controls}$$

$$\phi = 0.7$$

This catalog

$$\phi V_{cp} = (0.7)(7,028) = 4,920 \text{ lb.} > 440 \text{ lb.} - \text{OK}$$

Example Calculation *Adhesive Anchors (ICC-ES AC308)*

Continued from previous page.

CALCULATIONS AND DISCUSSION

REFERENCE

10. Check all failure modes under shear loading:

D.4.1.2

Summary:

Steel capacity = 6,923 lb.

Concrete breakout capacity = 666 lb. ← **Controls**

Pryout capacity = 4,920 lb.

∴ $\phi V_n = 666$ lb. as concrete breakout capacity controls

11. Check interaction of tension and shear forces:

D.7

If $0.2 \phi V_n \geq V_{ua}$, then the full tension design strength is permitted.

D.7.1

By observation, this is not the case.

If $0.2 \phi N_n \geq N_{ua}$, then the full shear design strength is permitted

D.7.2

By observation, this is not the case.

Therefore:

$$\frac{N_{ua}}{\phi N_n} + \frac{V_{ua}}{\phi V_n} \leq 1.2 \quad \text{Eq. (D-31)}$$

$$\frac{1,040}{2,284} + \frac{440}{666} = 0.46 + 0.66 = 1.12 < 1.2 - \text{OK}$$

12. Summary

A single ½" diameter ASTM A193 Grade B7 anchor rod in SET-XP® epoxy adhesive at a 4 ½" embedment depth is adequate to resist the applied service tension and shear loads of 650 lb. and 275 lb., respectively.

Glossary Of Common Terms

ACI - American Concrete Institute

ACRYLIC - The generic term for adhesive products made from methylmethacrylate resins.

ADHESIVE ANCHOR - Typically, a threaded rod or rebar that is installed in a predrilled hole in a base material with a two-part chemical compound.

ADMIXTURE - A material other than water, aggregate, or hydraulic cement used as an ingredient of concrete and added to concrete before or during its mixing to modify its properties.

AERATED CONCRETE - Concrete that has been mixed with air-entraining additives to protect against freeze-thaw damage and provide additional workability.

AGGREGATE - A granular material, such as sand, gravel, crushed stone and iron blast-furnace slag, used with a cementing medium to form a hydraulic cement concrete or mortar.

AISC - American Institute of Steel Construction

ALLOWABLE LOAD - The maximum design load that can be applied to an anchor. Allowable loads for mechanical and adhesive anchors are based on applying a factor of safety to the average ultimate load.

ALLOWABLE STRESS DESIGN (ASD) - A design method in which an anchor is selected such that service loads do not exceed the anchor's allowable load. The allowable load is the average ultimate load divided by a factor of safety.

AMINE - An ingredient used in epoxy as a curing agent.

ANCHOR CATEGORY - The classification for an anchor that is established by the performance of the anchor in reliability tests such as sensitivity to reduced installation effort for mechanical anchors or sensitivity to hole cleaning for adhesive anchors.

ANSI - American National Standards Institute

ASTM - American Society for Testing and Materials

BASE MATERIAL - The substrate (e.g. - concrete, CMU, etc.) into which adhesive or mechanical anchors are to be installed.

BOND STRENGTH - The mechanical interlock or chemical bonding capacity of an adhesive to both the insert and the base material.

BRICK - A solid masonry unit of clay or shale, formed into a rectangular prism while plastic and burned or fired in a kiln that may have cores or cells comprising of less than 25% of the cross sectional area.

CAMA - Concrete Anchor Manufacturer's Association.

CAST-IN-PLACE ANCHOR - A headed bolt, stud or hooked bolt installed into formwork prior to placing concrete.

CHARACTERISTIC DESIGN VALUE - The nominal strength for which there is a 90% confidence that there is a 95% probability of the actual strength exceeding the nominal strength.

CONCRETE - A mixture of Portland cement or any other hydraulic cement, fine aggregate, coarse aggregate and water, with or without admixtures. Approximate weight is 150 pcf.

CONCRETE BRICK - A solid concrete masonry unit (CMU) made from portland cement, water, and aggregates.

CONCRETE COMPRESSIVE STRENGTH (f'_c) - The specified compressive load carrying capacity of concrete used in design expressed in pounds per square inch (psi) or megapascals (MPa).

CONCRETE MASONRY UNIT (CMU) - A hollow or solid masonry unit made from cementitious materials, water and aggregates.

CORE DRILL - A method of drilling a smooth wall hole in a base material using a special drill attachment.

CREEP - Displacement under a sustained load over time.

CURE TIME - The elapsed time required for an adhesive anchor to develop its ultimate carrying capacity.

DESIGN LOAD - The calculated maximum load that is to be applied to the anchor for the life of the structure.

DESIGN STRENGTH - The nominal strength of an anchor calculated per ACI 318, ICC-ES AC193 or ICC-ES AC308 and then multiplied by a strength reduction factor (ϕ).

DROP-IN ANCHOR - A post-installed mechanical anchor consisting of an internally-threaded steel shell and a tapered expander plug. The bottom end of the steel shell is slotted longitudinally into equal segments. The anchor is installed in a pre-drilled hole using a hammer and a hand setting tool. The anchor is set when the tapered expander plug is driven toward the bottom end of the anchor such that the shoulder of the hand setting tool makes contact with the top end of the anchor. A Drop-In Anchor may also be referred to as a displacement controlled expansion anchor.

DYNAMIC LOAD - A load whose magnitude varies with time.

EDGE DISTANCE:

EDGE DISTANCE (C) - The measure between the anchor centerline and the free edge of the concrete or masonry member.

CRITICAL EDGE DISTANCE (C_{cr} or C_{ag}) - The least edge distance at which the allowable load capacity of an anchor is applicable without reductions.

MINIMUM EDGE DISTANCE (C_{min}) - The least edge distance at which the anchors are tested for recognition.

EFFECTIVE EMBEDMENT DEPTH - The dimension measured from the concrete surface to the deepest point at which the anchor tension load is transferred to the concrete.

EMBEDMENT DEPTH - The distance from the top surface of the base material to the installed end of the anchor. In the case of a post-installed mechanical anchor, the embedment depth is measured prior to application of the installation torque.

EPOXY - A thermosetting resin made by combining mainly Dylglycidyl Ether or Bisphenol-A and a Polyamine curing agent.

EXPANSION ANCHOR - A mechanical fastener placed in hardened concrete or assembled masonry, designed to expand in a self-drilled or predrilled hole of a specified size and engage the sides of the hole in one or more locations to develop shear and/or tension resistance to applied loads without grout, adhesive or drypack.

FATIGUE LOAD TEST - A test in which the anchor is subjected to a specified load magnitude for 2×10^6 cycles in order to establish the endurance limit of the anchor.

GEL TIME - The elapsed time at which an adhesive begins to increase in viscosity and becomes resistant to flow.

GREEN CONCRETE - Concrete that has cured for less than 28 days.

GROUT - A mixture of cementitious material and aggregate to which sufficient water is added to produce pouring consistency without segregation of the constituents.

GROUTED MASONRY (or GROUT-FILLED MASONRY) - Hollow-unit masonry in which the cells are filled solidly with grout. Also, double or triple-wythe wall construction in which the cavity(s) or collar joint(s) is filled solidly with grout.

HOT-DIP GALVANIZED - A part coated with a relatively thick layer of zinc by means of dipping the part in molten zinc. Hot-dip galvanizing provides a medium level of corrosion resistance.

ICC ES - International Code Council Evaluation Service.

LIGHTWEIGHT CONCRETE - Concrete containing lightweight aggregate. The unit weight of lightweight concrete is not to exceed 115 pcf.

MASONRY - Brick, structural clay tile, stone, concrete masonry units or a combination thereof bonded together with mortar.

MECHANICALLY GALVANIZED - A part coated with a layer of zinc by means of mechanical impact. The thickest levels of mechanical galvanizing (ASTM B695, Class 55 or greater) are considered to be alternatives to hot-dip galvanizing and provide a medium level of corrosion resistance

MERCAPTAN - An ingredient used in epoxy as a curing agent.

MORTAR - A mixture of cementitious materials, fine aggregate, and water, used to bond masonry units together.

NOMINAL STRENGTH - The strength of an element as calculated per ACI 318, ICC-ES AC193 or ICC-ES AC308.

NORMAL WEIGHT CONCRETE - Concrete containing normal weight aggregate. The unit weight of normal weight concrete is approximately 150 pcf.

Glossary Of Common Terms

OBLIQUE LOAD - A load that is applied to an anchor, which can be resolved into tension and shear components.

POLYESTER - The generic term for adhesive products made primarily from polyester resins.

PLAIN CONCRETE - Structural concrete with no reinforcement or with less reinforcement than the minimum specified for reinforced concrete.

PORTLAND CEMENT - Hydraulic cement consisting of finely pulverized compounds of silica, lime and alumina.

POST-INSTALLED ANCHOR - Either a mechanical or adhesive anchor installed in a pre-drilled hole in the base material.

POST-TENSION - A method of prestressing in which tendons are tensioned after concrete has hardened.

POT LIFE - The length of time a mixed adhesive remains workable (flowable) before hardening.

PRECAST CONCRETE - A concrete structural element cast elsewhere than its final position in the structure.

PRESTRESSED CONCRETE - Structural concrete in which internal stresses have been introduced to reduce potential tensile stresses in concrete resulting from loads.

PRETENSIONING - A method of prestressing in which tendons are tensioned before concrete is placed.

REBAR - Deformed reinforcing steel which comply with ASTM A615.

REINFORCED CONCRETE - Structural concrete reinforced with no less than the minimum amount of prestressed tendons or nonprestressed reinforcement specified in ACI 318.

REINFORCED MASONRY - Masonry units and reinforcing steel bonded with mortar and/or grout in such a manner that the components act together in resisting forces.

REQUIRED STRENGTH - The factored loads and factored load combinations that must be resisted by an anchor.

SCREEN TUBE - Typically a wire or plastic mesh tube used with adhesives for anchoring into hollow base materials to prevent the adhesive from flowing uncontrolled into voids.

SCREW ANCHOR - A post-installed anchor that is a threaded mechanical fastener placed in a predrilled hole. The anchor derives its tensile holding strength from the mechanical interlock of the fastener threads with the grooves cut into the concrete during the anchor installation.

SEISMIC LOAD TEST - A test in which the anchor is subjected to load cycles of varying magnitude and frequency for the purpose of simulating a seismic event.

SHEAR LOAD - A load applied perpendicular to the axis of an anchor.

SHOTCRETE - Concrete that is pneumatically projected onto a surface at high velocity. Also known as gunite.

SLEEVE ANCHOR - A post-installed mechanical anchor consisting of a steel stud with nut and washer, threaded on the top end and a formed uniform tapered mandrel on the opposite end around which a full length expansion sleeve formed from sheet steel is positioned. The anchor is installed in a predrilled hole and set by tightening the nut by torquing thereby causing the expansion sleeve to expand over the tapered mandrel to engage the base material.

SPACING:

SPACING (S) - The measure between anchors, centerline-to-centerline distance.

CRITICAL SPACING (S_{cr}) - The least anchor spacing distance at which the allowable load capacity of an anchor is applicable such that the anchor is not influenced by neighboring anchors.

MINIMUM SPACING (S_{min}) - The least anchor spacing at which the anchors are tested for recognition.

STAINLESS STEEL - A family of iron alloys containing a minimum of 12% chromium. Stainless steels have a high level of corrosion resistance. Type 316 stainless steel provides greater corrosion resistance than Types 303 or 304.

STANDARD DEVIATION - As it pertains to this catalog, a statistical measure of how widely dispersed the individual test results were from the published average ultimate loads.

STATIC LOAD - A load whose magnitude does not vary appreciably over time.

STRENGTH DESIGN (SD) - A design method in which an anchor is selected such that the anchor's design strength is equal to or greater than the anchor's required strength.

STRENGTH REDUCTION FACTOR (ϕ) - A factor applied to the nominal strength to allow for variations in material strengths and dimensions, inaccuracies in design equations, required ductility and reliability and the importance of the anchor in the structure.

TENDON - In pretensioned applications, the tendon is the prestressing steel. In post-tensioned applications, the tendon is a complete assembly consisting of anchorages, prestressing steel, and sheathing with coating for unbonded applications or ducts with grout for bonded applications.

TENSION LOAD - A load applied parallel to the axis of an anchor.

THIXOTROPIC - The ability of a gel to become less viscous (resistance to flow) under pressure then thicken when pressure is released.

TORQUE - The measure of the force applied to produce rotational motion usually measured in foot-pounds. Torque is determined by multiplying the applied force by the distance from the pivot point to the point where the force is applied.

ULTIMATE LOAD - The average value of the maximum loads that were achieved when five or more samples of a given product were installed and statically load tested to failure under similar conditions. The ultimate load is used to derive the allowable load by applying a factor of safety.

UNDERCUT ANCHOR - A post-installed anchor that develops its tensile strength from the mechanical interlock provided by undercutting of the concrete at the embedded end of the anchor.

UNREINFORCED MASONRY (URM) - A form of clay brick masonry bearing wall construction consisting of multiple wythes periodically interconnected with header courses. In addition, this type of wall construction contains less than the minimum amounts of reinforcement as defined for reinforced masonry walls.

VIBRATORY LOAD TEST - As prescribed by the UL 203 standard, a test in which a 150 pound concrete block is hung from the anchor and vibrated with an amplitude of 0.0325" at a frequency of 35 Hz for 100 hours.

VINYLESTER - An adhesive blend of epoxy and vinyl acrylate resins.

VISCOSITY - The resistance of a fluid to flow measured in centipoise (cps). The viscosity of water is 1.0 cps. Guidelines for categories of epoxies: 1–200 cps: super low viscosity; 200–2000 cps: low viscosity; 2000–10,000 cps: medium viscosity; above 10,000 cps is classified as a non-sag gel. High viscosity = high resistance to flow, low viscosity = low resistance to flow.

WEDGE ANCHOR - A post-installed mechanical anchor consisting of a steel stud with nut and washer, threaded on the top end and a formed uniform tapered mandrel on the opposite end around which an expansion clip formed from sheet steel is positioned. The anchor is installed in a predrilled hole and set by tightening the nut by torquing thereby causing the expansion clip to expand over the tapered mandrel to engage the base material. A wedge anchor may also be referred to as a torque controlled expansion anchor.

WYTHE - A continuous vertical section of masonry one unit in thickness.

ZINC PLATED - A part coated with a relatively thin layer of zinc by means of electroplating. Zinc plating provides a low level of corrosion resistance.

Special Section

Introducing
**Connectors for
Cold-Formed Steel
Curtain-Wall Construction**

Code Listed: IAPMO ES ER-238

(800) 999-5099
www.strongtie.com

Our Newest Product Line for Cold-Formed Steel Framing

Simpson Strong-Tie is committed to providing an expanded product range for cold-formed steel applications, and has developed a new line of connectors for use with curtain-wall steel stud framing. Curtain-wall projects require a variety of connectors that provide a load path from the curtain wall to the primary structure for wind loads, seismic loads and dead loads. Slide-clip connectors enable the structural building frame to deflect independently of the curtain-wall system. Fixed-clip connectors support the dead load of a curtain wall from the structural frame. Fixed clips have the added benefit of providing connector solutions for load-bearing walls and for roof systems utilizing steel trusses and rafters.

Our connectors for curtain-wall construction accommodate many different bypass framing applications in a variety of stand-off conditions. We also offer connectors for head-of-wall and strut applications.

Tailored To Your Design

All our standard slide clips accommodate 1" of both upward and downward movement, equivalent to an L/360 live-load deflection for a 30' span. Our standard clips also accommodate stand-offs as large as 12 1/4". For deflections greater than 1", or stand-offs greater than 12 1/4", Simpson Strong-Tie can provide custom clips to suit most framing needs (see page 12). Our SCB and SCW slide-clip connectors can be manufactured for 1 3/8" of both upward and downward movement. Please call us for information about this option.

Complete, Tested Solutions

Designers of curtain walls will often know the capacity of a connector, but since the capacity does not take into account the way in which the connector is anchored to the supporting structure, the Designer must then manually calculate this important aspect of the connection design. These calculations are complicated by considerations of eccentric and prying forces that often exist but are difficult to predict. Through comprehensive testing Simpson Strong-Tie provides total, code-listed connector solutions. Our testing extends from the capacity of the connector and its attachment to the framing, to the anchorage of the connector to the primary structure. By providing complete data on the entire connection system, we save the Designer time and ensure that all forces, including eccentric and prying forces, are adequately considered.

As with all Simpson Strong-Tie® products, our slide-clip and fixed-clip connectors for curtain-wall steel stud framing carry our promise of quality and performance, and are backed by prompt, knowledgeable service.

The following information is effective until December 31, 2012. After this date, visit www.strongtie.com for updated information

For other pertinent information, please refer to the Important Information and General Notes pages in the current Simpson Strong-Tie® *Cold-Formed Steel Connectors for Residential and Mid-Rise Construction* catalog. For limited warranty information and terms and conditions of sale, please visit www.strongtie.com. For special orders, call us at (800) 999-5099.

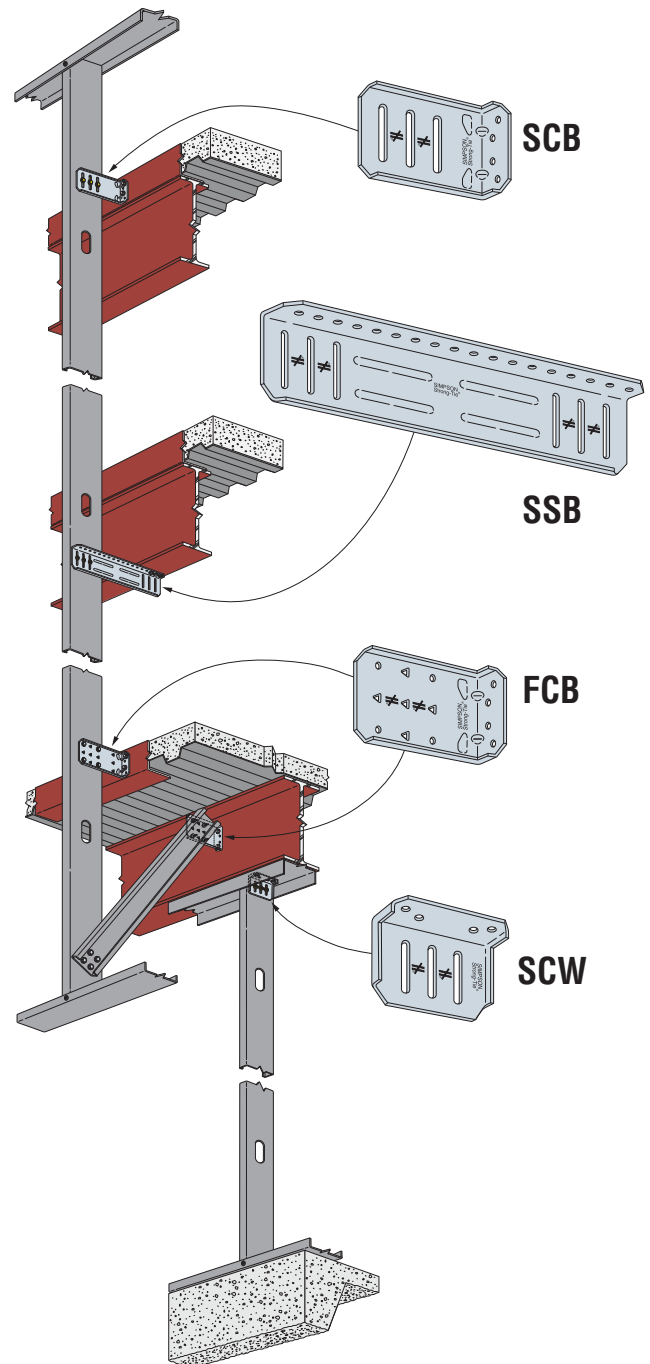

Code Listed: IAPMO ES ER-238

General Notes

General Notes for Allowable Connector Load Tables

1. Allowable loads are for use when utilizing the traditional Allowable Stress Design methodology. Contact Simpson Strong-Tie® for LRFD loads.
2. Allowable loads are based on cold-formed steel members with a minimum yield strength, F_y , of 33 ksi and tensile strength, F_u , of 45 ksi for 43 mils (18 ga.) and thinner, and a minimum yield strength of 50 ksi and tensile strength of 65 ksi for 54 mils (16 ga.) and thicker.
3. The tabulated values for 54 mil (16 ga.) are applicable for framing members thicker than 54 mil (16 ga.) with a minimum yield strength of 50 ksi and tensile strength of 65 ksi.
4. Allowable loads for the SCB, SCW and SSB connectors are based on #14 shouldered screws (provided with connectors) installed in the center of the slots.
5. Allowable loads may not be increased for wind or seismic load.
6. Clips do not replace stud lateral or stability bracing. Design of bracing is the responsibility of the Designer.
7. It is the responsibility of the Designer to verify the adequacy of the stud. Allowable loads are based on clips installed an adequate distance away from penetrations, notches, ends of studs and other conditions that may affect the clip performance.
8. Industry studies show that hardened fasteners can experience performance problems in wet or corrosive environments. Accordingly, use these products in dry and non-corrosive environments only.

General Notes for Allowable Anchorage Load Tables

1. Allowable loads are for use when utilizing the traditional Allowable Stress Design methodology. Contact Simpson Strong-Tie for LRFD loads.
2. Allowable loads may not be increased for wind or seismic load.
3. Allowable loads for #12-14 self-drilling screws are based on a minimum nominal shear strength, P_{ss} , of 2485 lbs., and nominal tension strength, P_{ts} , of 2595 lbs.
4. Allowable loads for #12-14 self-drilling screws and PDPT powder-actuated fasteners are based on installation in minimum $\frac{3}{16}$ " thick structural steel with $F_y = 36$ ksi. It is the responsibility of the Designer to select the proper length fasteners based on the installation.
5. Allowable loads for Simpson Strong-Tie® Titen® screws are based on installation in concrete with a minimum $f'_c = 2500$ psi and a maximum $f'_c = 4000$ psi. Reference the current *Anchoring and Fastening Systems for Concrete and Masonry* catalog and its Addendum for more information about Titen screws.
6. Allowable loads for welded connections require E70XX electrodes with a minimum throat size equal to the clip thickness. Welding shall be in compliance with AWS D1.3. Welding galvanized steel may produce harmful fumes; follow proper welding procedures and precautions.
7. Allowable loads are for anchorage only. It is the responsibility of the Designer to verify the strength and stability of the structure for the loads imposed by the cold-formed steel framing connections.
8. Industry studies show that hardened fasteners can experience performance problems in wet or corrosive environments. Accordingly, use these products in dry and non-corrosive environments only.

When It Comes to Fastening Curtain-Wall Clips with P.A.T. or Concrete Screws, We've Got You Covered

In addition to self-drilling screws and welding, Simpson Strong-Tie® connectors for curtain-wall construction are designed to be fastened with our powder-actuated fasteners and concrete screws.

PDPT and PDPAT Tophat Fasteners

The PDPT powder-actuated pins called out in this flier are part of the Simpson Strong-Tie® jobsite-proven P.A.T. system. These fasteners are pins with .300" heads and a .145" (PDPT) or 0.157" (PDPAT) shank diameter and feature a "tophat" which ensures adequate clamping force and consistent installations. They are suitable for use with the majority of Simpson Strong-Tie powder-actuated tools as well as tools from other popular manufacturers.



Titen® Concrete and Masonry Screws

Titen screws are heat-treated fasteners designed to attach all types of fixtures to concrete and masonry. They install easily in a pre-drilled hole and include a drill bit in each box. Available in both hex and flat head styles, the hex-head version is required for Simpson Strong-Tie connectors for curtain-wall construction.



For more information on our full line of anchoring and fastening systems for concrete and masonry, visit www.strongtie.com or reference our *Anchoring and Fastening Systems for Concrete and Masonry* catalog.

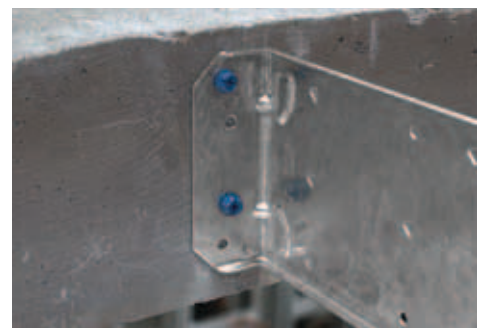

SCB Bypass Framing Slide-Clip Connector

The SCB slide-clip connector is a time-saving, high-performance slide-clip connector for bypass framing applications that simplifies design and detailing for the Designer and reduces field labor and material costs. Providing allowable anchorage loads for these connectors – with powder-actuated pins, screws, welds or Simpson Strong-Tie® Titen® concrete screws – eliminates the need to design this anchorage. For designs that have typically required two parts to accommodate large stand-offs, the SCB can take their place, thereby reducing field labor. The connector is manufactured in five different lengths to accommodate a variety of stand-off conditions and steel stud sizes.

FEATURES:

- Provides a full 1" of both upward and downward movement
- Clips that allow 1 3/4" of upward and downward movement are available by special order. Contact Simpson Strong-Tie for details
- The precision-manufactured shouldered screws provided with the SCB connector are designed to prevent overdriving and to ensure the clip functions properly
- Strategically placed stiffeners, embossments and anchor holes maximize connector performance
- Simpson Strong-Tie® "No-Equal" stamps mark the center of the slots to help ensure correct shouldered-screw placement

MATERIAL: 54 mil (16 ga.)

FINISH: Galvanized (G90)

INSTALLATION:

- Use the specified type and number of anchors.
- Use the specified number of #14 shouldered screws (included). Install shouldered screws in the slots adjacent to the "No-Equal" stamp.
- Use a maximum of 1 screw per slot.

CODES: IAPMO ES ER-238

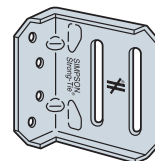

SCB43.5

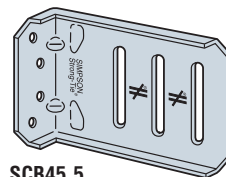

SCB45.5

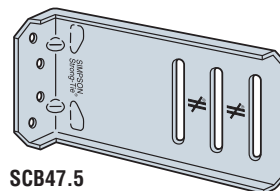

SCB47.5

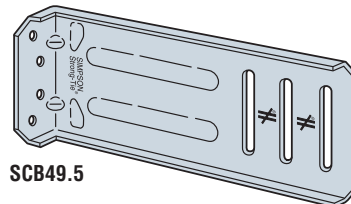

SCB49.5

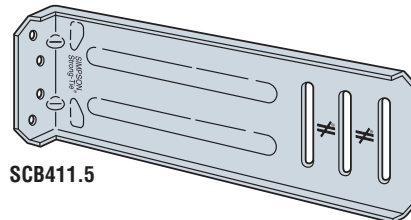

SCB411.5

U.S. Patent Pending

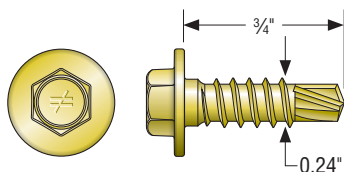

#14 Shouldered Screw

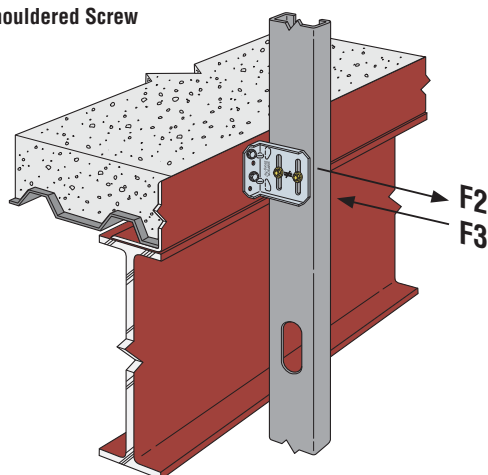

Typical SCB Installation

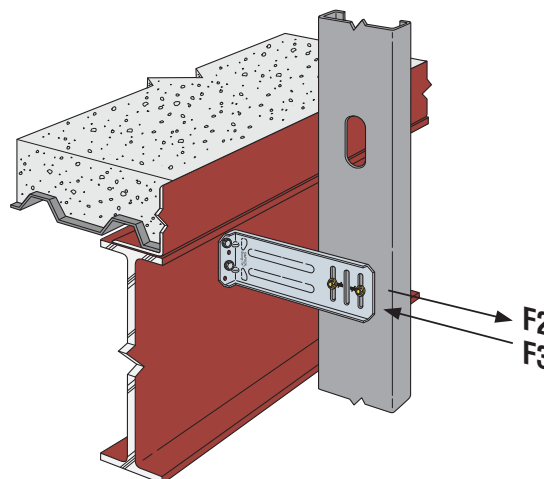

SCB Installation at Fascia Beam

SCB Bypass Framing Slide-Clip Connector

SCB Allowable Connector Loads (lbs.)

Model No.	Connector Material Thickness mil (ga.)	L (in.)	No. of #14 Shouldered Screws	Stud Thickness					
				33 mil (20 ga.)		43 mil (18 ga.)		54 mil (16 ga.)	
				F2	F3	F2	F3	F2	F3
SCB43.5	54 (16)	3 1/2	2	520	520	610	690	760	975
SCB45.5	54 (16)	5 1/2	2 ²	490	520	610	690	760	975
			3	675	675	895	1000	990	1260
SCB47.5	54 (16)	7 1/2	2 ²	490	520	610	690	760	945
			3	675	675	895	1000	990	1260
SCB49.5	54 (16)	9 1/2	2 ²	490	520	690	690	760	945
			3	675	675	895	1000	990	1260
SCB411.5	54 (16)	11 1/2	2 ²	490	520	690	690	990	920
			3	675	675	860	1000	990	1260

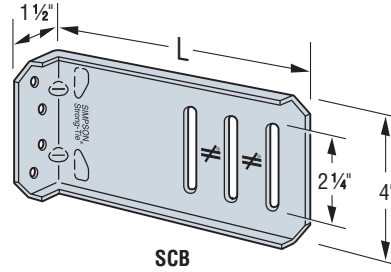

- For additional important information, see General Notes for Allowable Connector Load Tables on page 242.
- When the SCB connector is used with 2 shouldered screws, the screws may be installed in any 2 slots.
- Allowable loads are based on clips installed with (4) #12-14 screws in the anchor leg. For other anchorage installations, the capacity of the connection system will be the minimum of the tabulated value and the allowable load from the SCB Allowable Anchorage Loads table below.

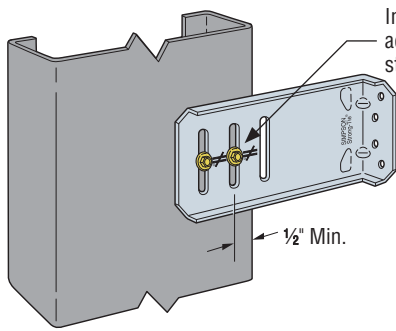

SCB Installation with 2 Shouldered Screws

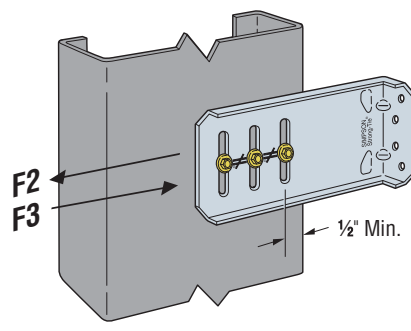

SCB Installation with 3 Shouldered Screws

SCB Allowable Anchorage Loads (lbs.)

Anchorage Type	No. of Anchors	Allowable Loads F2 and F3
#12-14 Self-Drilling Screws	2	795
	3	1120
	4	1260
Simpson Strong-Tie® 0.145" PDPT or 0.157" PDPAT Powder-Actuated Fasteners	2	280
	3	390
	4	555
1/4"x1 3/4" Simpson Strong-Tie® Titen® Hex-Head Screws	2	380
	3	445
	4	510
Welded	Hard side: 2" Free side: 1"	1260

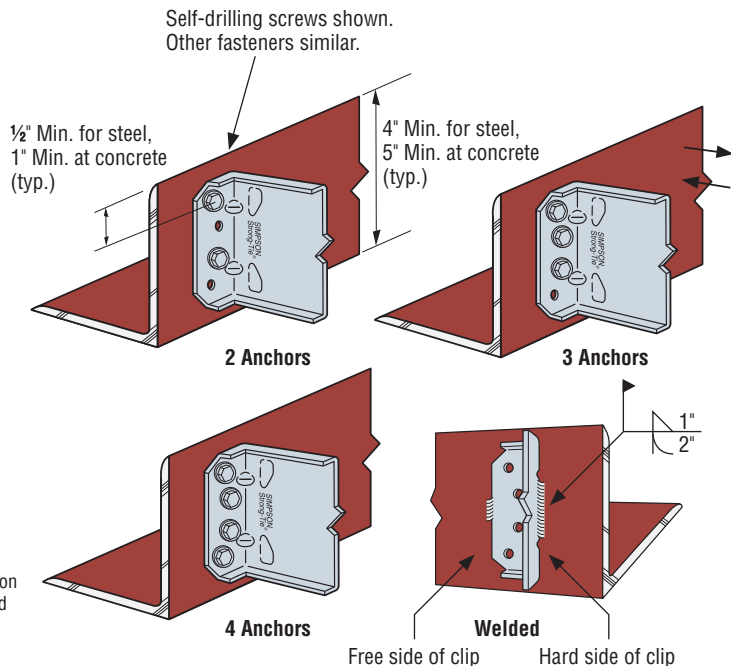

SCB Anchor Layout

- For additional important information, see General Notes for Allowable Anchorage Load Tables on page 242.
- Allowable loads are for clip anchorage only. The capacity of the connection system will be the minimum of the tabulated value and the allowable load from the SCB Allowable Connector Loads table above.

SCW Head-of-Wall Slide-Clip Connector

SCW slide-clip connectors are primarily used in head-of-wall applications that require vertical movement relative to the structure. The connector can also be used to strengthen window and door jambs for projects that utilize slip-track.

FEATURES:

- Provides a full 1" of both upward and downward movement
- Clips that allow 1 3/8" of upward and downward movement are available by special order. Contact Simpson Strong-Tie for details
- The precision-manufactured shouldered screws provided with the SCW connector are designed to prevent overdriving and to ensure the clip functions properly
- Anchor holes located to maximize performance
- Simpson Strong-Tie® "No-Equal" stamps mark the center of the slots to help ensure correct shouldered-screw placement

MATERIAL: 54 mil (16 ga.)

FINISH: Galvanized (G90)

INSTALLATION:

- Use the specified type and number of anchors.
- Use the specified number of #14 shouldered screws (included). Install shouldered screws in the slots adjacent to the "No-Equal" stamp.
- Use a maximum of 1 screw per slot.

CODES: IAPMO ES ER-238

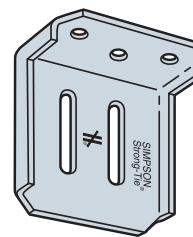

SCW3.25

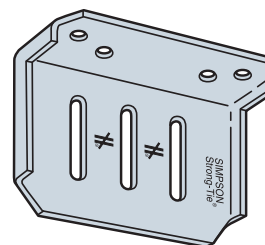

SCW5.5

U.S. Patent Pending

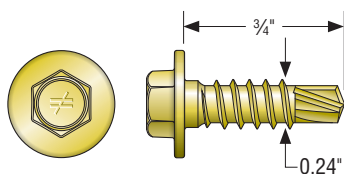

#14 Shouldered Screw

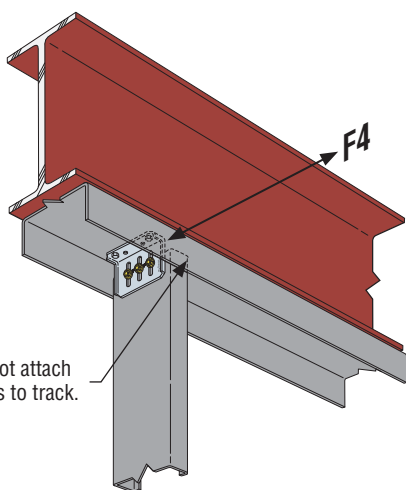

Typical SCW Installation at Stud

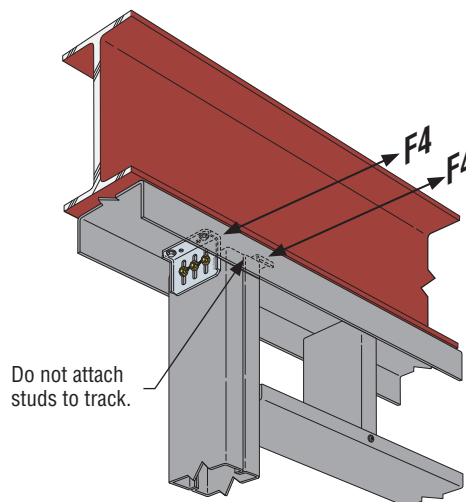

Typical SCW Installation at Window or Door Jamb

SCW Head-of-Wall Slide-Clip Connector

SCW Allowable Connector Loads (lbs.)

Model No.	Connector Material Thickness mil (ga.)	W (in.)	No. of #14 Shouldered Screws	Stud Thickness		
				33 mil (20 ga.)	43 mil (18 ga.)	54 mil (16 ga.)
				F4	F4	F4
SCW3.25	54 (16)	3 ¼	2	455	630	755
SCW5.5	54 (16)	5 ½	2 ²	455	630	995
			3	455	630	1220

- For additional important information, see General Notes for Allowable Connector Load Tables on page 242.
- When the SCW5.5 connector is used with 2 shouldered screws, install screws in the outermost slots.
- Allowable loads are based on clips installed with all holes in the anchor leg filled with #12-14 screws. For other anchorage installations, the capacity of the connection system will be the minimum of the tabulated value and the allowable load from the SCW Allowable Anchorage Loads table below.

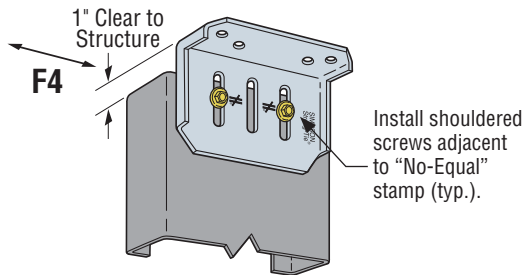
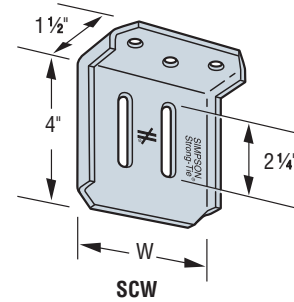

SCW5.5 Installation with 2 Shouldered Screws
(3 shouldered screws and SCW3.25 similar)

SCW Allowable Anchorage Loads (lbs.)

Model No.	Anchorage Type	No. of Anchors	Allowable Loads F4
SCW3.25	#12-14 Self-Drilling Screws	2	640
		3	755
	Simpson Strong-Tie® 0.145" PDPT or 0.157" PDPAT Powder-Actuated Fasteners	2	520
SCW5.5	#12-14 Self-Drilling screws	3	560
		4	1220
	Simpson Strong-Tie® 0.145" PDPT or 0.157" PDPAT Powder-Actuated Fasteners	2	920
		4	1220

- For additional important information, see General Notes for Allowable Anchorage Load Tables on page 242.
- Allowable loads are for clip anchorage only. The capacity of the connection system will be the minimum of the tabulated value and the allowable load from the SCW Allowable Connector Loads table above.

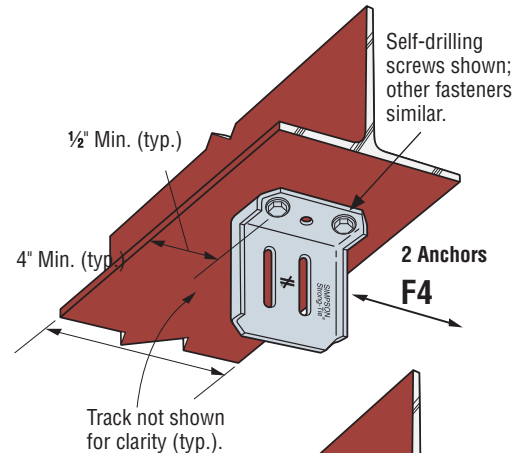

SCW3.25 Anchor Layout

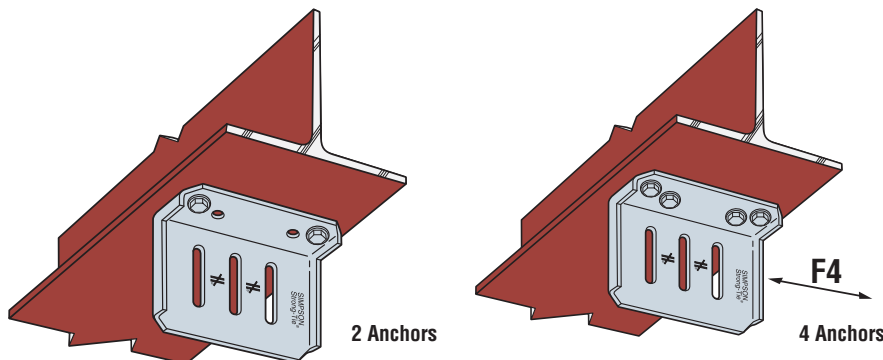

SCW5.5 Anchor Layout

SSB Bypass Framing Slide-Clip Strut Connector

The SSB bypass framing slide clip is a versatile strut connector that is commonly used at the bottom of a steel beam to accommodate large stand-off conditions.

FEATURES:

- Provides a full 1" of both upward and downward movement
- Anchor holes are positioned along the entire length of the part, and slots are located at each end so that lefts and rights are not required
- Embossments and stiffeners increase axial strength
- The precision-manufactured shouldered screws provided with the SSB connector are designed to prevent overdriving and to ensure the clip functions properly
- Simpson Strong-Tie® "No-Equal" stamps mark the center of the slots to help ensure correct shouldered-screw placement

MATERIAL: 54 mil (16 ga.)

FINISH: Galvanized (G90)

INSTALLATION:

- Use the specified type and number of anchors.
- Use the specified number of #14 shouldered screws (included). Install shouldered screws in the slots adjacent to the "No-Equal" stamp.
- Use a maximum of 1 screw per slot.

CODES: IAPMO ES ER-238

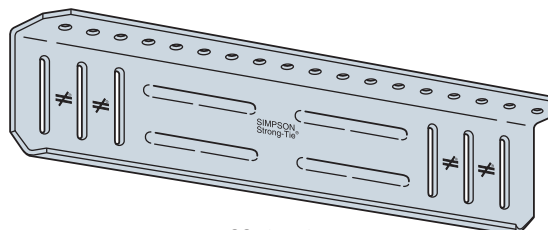

SSB3.518

U.S. Patent Pending

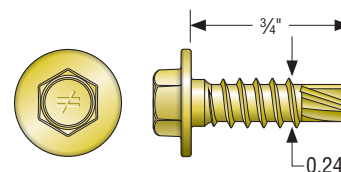

#14 Shouldered Screw

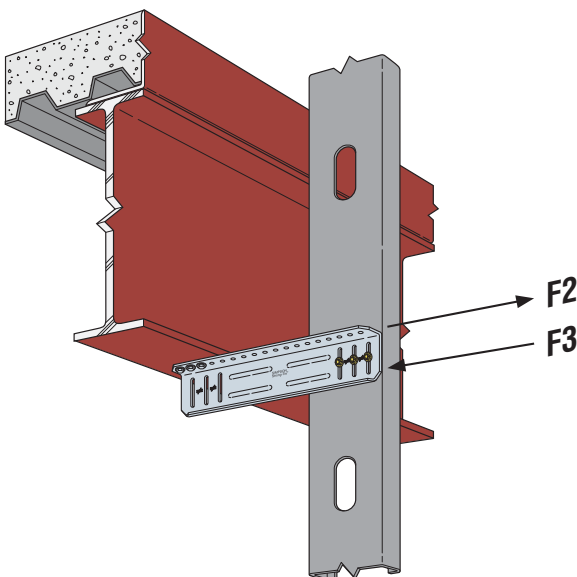

Typical SSB3.518 Installation

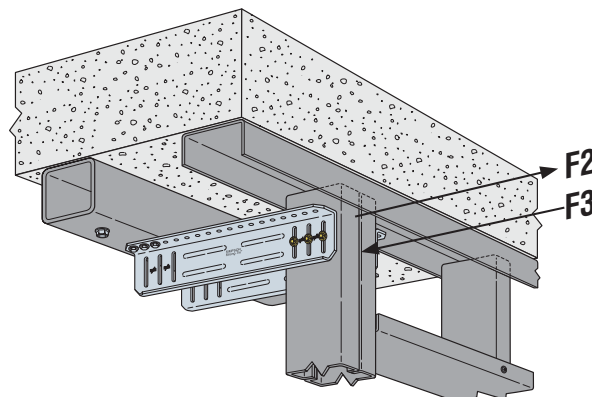

SSB3.518 Installation to Reinforce a Window/Door Jamb with Slip Track

SSB Bypass Framing Slide-Clip Strut Connector

SSB Allowable Connector Loads (lbs.)

Model No.	Connector Material Thickness mil (ga.)	No. of #14 Shouldered Screws	Stud Thickness					
			33 mil (20 ga.)		43 mil (18 ga.)		54 mil (16 ga.)	
			F2	F3	F2	F3	F2	F3
SSB3.518	54 (16)	2 ²	520	520	690	690	1075	960
		3	815	815	1030	1080	1335	1225

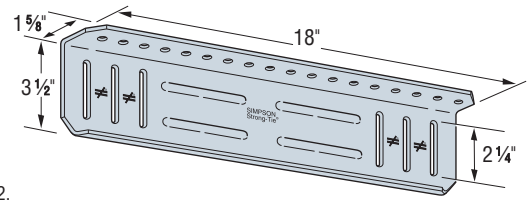

SSB

- For additional important information, see General Notes for Allowable Connector Load Tables on page 242.
- When the SSB connector is used with 2 shouldered screws, the screws may be installed in any 2 slots.
- Allowable loads are based on clips installed with (3) #12-14 screws in the anchor leg. For other anchorage installations, the capacity of the connection system will be the minimum of the tabulated value and the allowable load from the SSB Allowable Anchorage Loads table below.

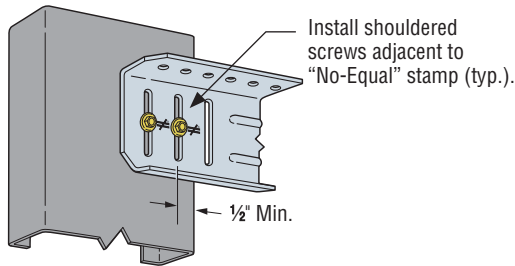

SSB Installation with 2 Shouldered Screws

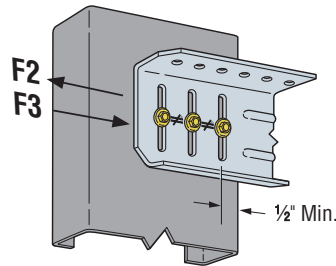

SSB Installation with 3 Shouldered Screws

SSB Allowable Anchorage Loads (lbs.)

Anchorage Type	No. of Anchors	Allowable Loads F2 and F3
#12-14 Self-Drilling Screws	2	1250
	3	1335
Simpson Strong-Tie® 0.145" PDPT or 0.157" PDPAT Powder-Actuated Fasteners	2	1320
	3	1335
Welded	Hard side: 2" Free side: 1"	1335

- For additional important information, see General Notes for Allowable Anchorage Load Tables on page 242.
- Allowable loads are for clip anchorage only. The capacity of the connection system will be the minimum of the tabulated value and the allowable load from the SSB Allowable Connector Loads table above.

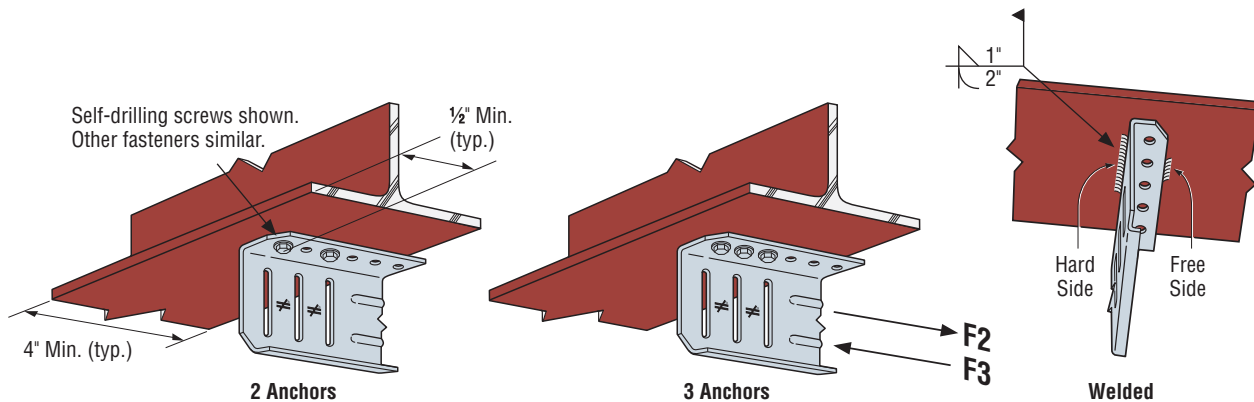

SSB Anchor Layout

FCB Bypass Framing Fixed-Clip Connector

The FCB clip is an economical, high-performance fixed-clip connector that can be used for a variety of framing applications. It is rated for tension, compression and shear loads and offers the Designer the flexibility of specifying different screw and anchorage patterns that conform to desired load levels.

FEATURES:

- Rated for tension, compression and shear loads
- Provides design flexibility with varying screw and anchorage patterns that achieve different load levels
- Strategically placed stiffeners, embossments and anchor holes maximize connector performance

MATERIAL: 54 mil (16 ga.)

FINISH: Galvanized (G90)

INSTALLATION:

- Use the specified type and number of anchors.
- Use the specified number of #12 self-drilling screws to CFS framing.

CODES: IAPMO ES ER-238

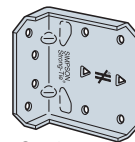

FCB43.5

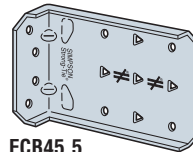

FCB45.5

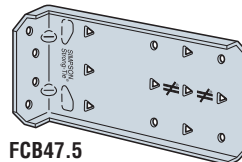

FCB47.5

U.S. Patent Pending

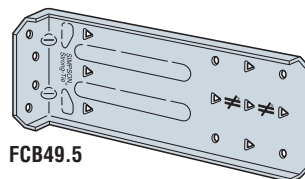

FCB49.5

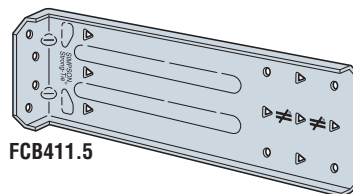

FCB411.5

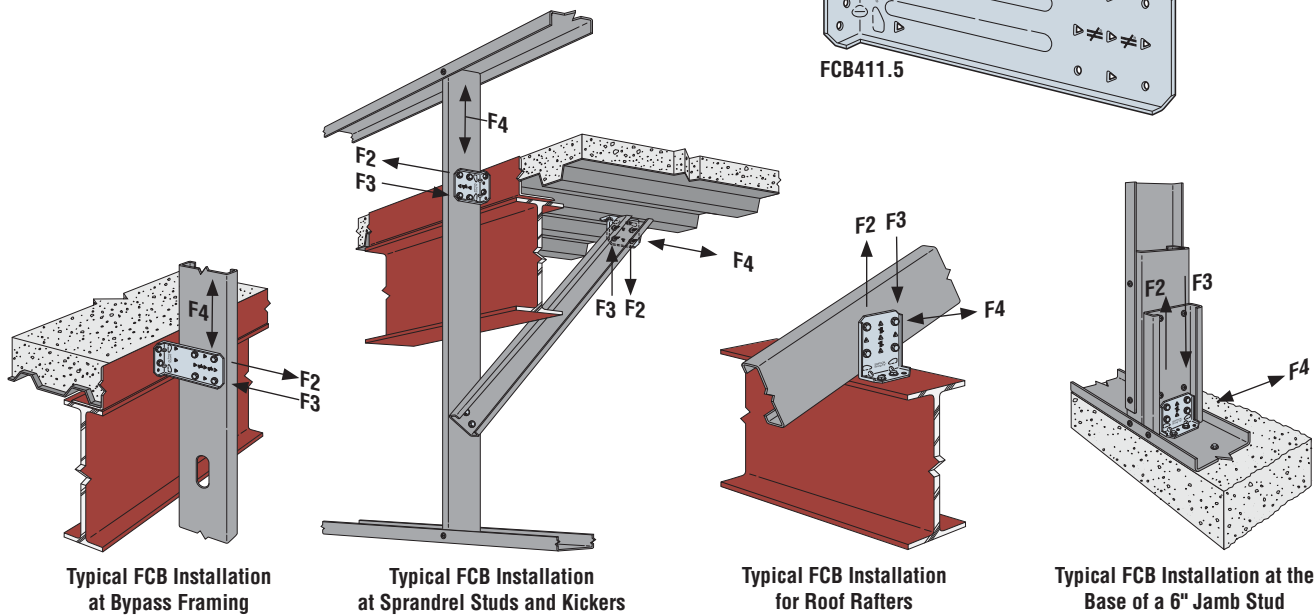

Contact Simpson Strong-Tie for the availability of FCB load tables for steel-to-steel framing.

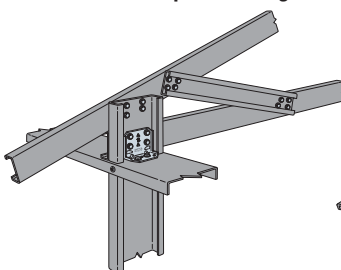

Truss to Top Track

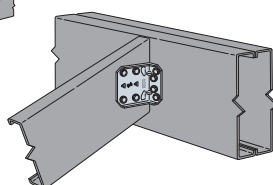

Roof Rafter to Ridge Beam

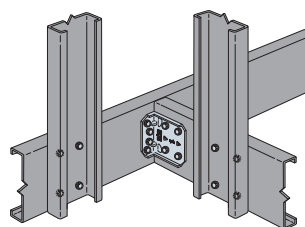

Jack Truss to Girder Truss

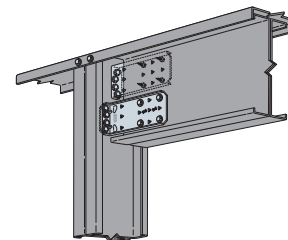

Header to Jamb Stud

FCB Bypass Framing Fixed-Clip Connector

FCB Allowable Connector Loads (lbs.)

Model No.	Connector Material Thickness mil (ga.)	L (in.)	Min./Max.	No. of #12-14 Self-Drilling Screws	Stud Thickness								
					33 mil (20 ga.)			43 mil (18 ga.)			54 mil (16 ga.)		
					F2	F3	F4	F2	F3	F4	F2	F3	F4
FCB43.5	54 (16)	3 1/2	Min.	4	755	755	755	1105	975	1120	1250	975	1490
			Max.	6	1100	1130	1130	1105	1260	1455	1250	1735	1910
FCB45.5	54 (16)	5 1/2	Min.	4	755	755	755	1105	975	945	1105	975	1325
			Max.	9	1100	1260	1180	1105	1260	1485	1105	1735	1925
FCB47.5	54 (16)	7 1/2	Min.	4	755	755	220	1105	945	330	1105	945	365
			Max.	12	1100	1260	705	1105	1260	1050	1105	1735	1445
FCB49.5	54 (16)	9 1/2	Min.	4	755	755	170	1105	945	255	1105	945	365
			Max.	12	1100	1260	750	1105	1260	1115	1105	1735	1200
FCB411.5	54 (16)	11 1/2	Min.	4	755	755	140	1105	920	205	1105	920	365
			Max.	12	1100	1260	795	1105	1260	860	1105	1735	860

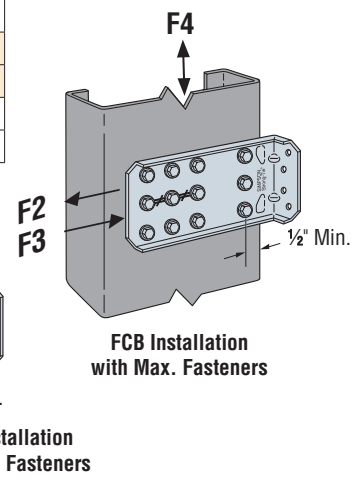
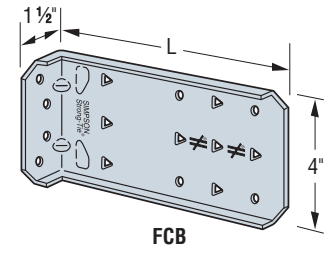

- For additional important information, see General Notes for Allowable Connector Load Tables on page 242.
- Allowable loads for #12-14 self-drilling screws are based on a minimum $P_{ss} = 2560$ lbs. and $P_{ts} = 2595$ lbs.
- Min. fastener quantity and load values—fill all round holes; max. fastener quantity and load values—fill all round and triangular holes.
- Allowable loads are based on clip capacity only and do not consider anchorage. The capacity of the connection system will be the minimum of the tabulated value and the allowable load from the FCB Allowable Anchorage Loads table below.

FCB Allowable Anchorage Loads (lbs.)

Anchorage Type	No. of Anchors	Allowable Loads (lbs.)								
		F2 and F3	F4							
			FCB43.5	FCB45.5	FCB47.5		FCB49.5		FCB411.5	
Min./Max.	Min./Max.	Min.	Max.	Min.	Max.	Min.	Max.	Min.	Max.	
#12-14 Self-Drilling Screws	2	795	625	410	255	445	185	265	120	190
	3	1120	690	450	280	490	200	295	135	210
	4	1585	1255	820	365	890	350	535	275	380
Simpson Strong-Tie® 0.145" PDPT or 0.157" PDPAT Powder-Actuated Fasteners	2	280	410	265	165	290	120	175	75	125
	3	390	465	305	190	330	135	195	85	140
	4	555	840	550	340	595	245	355	145	255
1/4"x1 3/4" Simpson Strong-Tie® Titen® Hex-Head Screws	2	380	415	270	165	295	120	175	215	125
	3	445	470	310	190	335	140	200	100	145
	4	510	645	420	260	455	190	275	280	195
Welded	Hard side: 2"	1735	1910	1925	365	1445	365	1200	365	860
	Free side: 1"									

- For additional important information, see General Notes for Allowable Anchorage Load Tables on page 242.
- Min. and max. refer to stud fasteners. See FCB Allowable Connector Loads table above.
- Allowable loads are for clip anchorage only. The capacity of the connection system will be the minimum of the tabulated value and the allowable load from the FCB Allowable Connector Loads table above.

Self-drilling screws shown. Other fasteners similar.

1/2" Min., for steel
1" Min. at concrete (typ.)

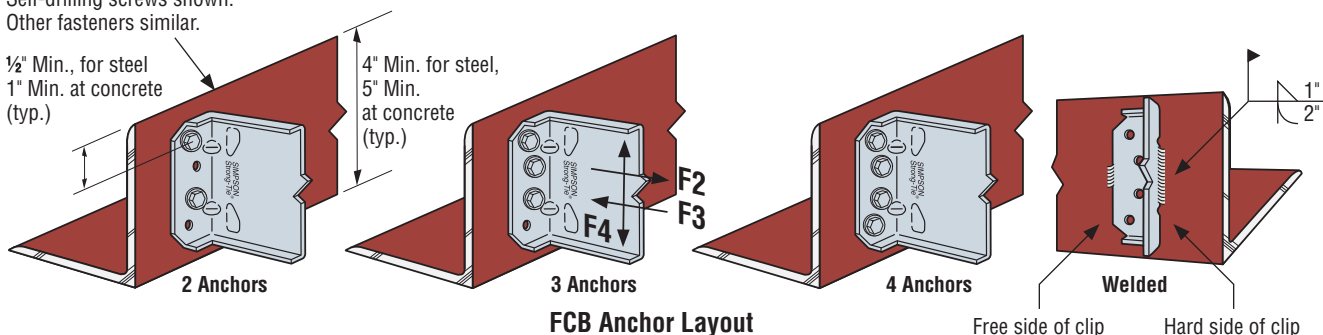

Custom Clips and Connectors

Simpson Strong-Tie can make a variety of flat and bent steel clips and connectors for cold-formed steel framing. Most custom clips can be punched with different holes and slots.

MATERIAL: 229 mil (3 ga.) maximum, 43 mil (18 ga.) minimum mill-certified steel (carbon and type 316L stainless steel)

FINISH: Galvanized, Simpson Strong-Tie® gray paint. Contact Simpson Strong-Tie for availability.

TO OBTAIN A QUOTE:

- Supply a CAD drawing in .dwg or .dxf format complete with all dimensions, hole diameter and centerline locations, bend angles, steel strength (min. Fy and Fu), thickness (mils and/or ga.) and finish: (galvanized to G90, G185) or Simpson Strong-Tie gray paint (specify).
- Total shape and size up to a maximum of 48" x 48" (approx. 1/16" tolerance).
- Simpson Strong-Tie does not provide product engineering or

load values for special-order custom clips and connectors.

- Contact Simpson Strong-Tie for pricing information.
- For additional information please refer to Important Information and General Notes in the Simpson Strong-Tie®, *Cold-Formed Steel Connectors for Residential and Mid-Rise Construction* catalog.

SPECIFICATION EXAMPLE:

QUANTITY: XX pieces

THICKNESS: 54 mil (16 ga.)

DIMENSIONS: Per the attached CAD drawing (.dwg or .dxf format)

STRENGTH: Min. Yield Strength (Fy) = 33 ksi, Min. Tensile Strength (Fu) = 45 ksi

Drawing must be fully dimensioned, including:

- Overall dimensions
- Leg dimensions
- Bend angles (if required)
- Hole/slot sizes and centerlines (if required)

FINISH: Galvanized G90

MATERIAL SPECIFICATION: (Contact Simpson Strong-Tie for availability)

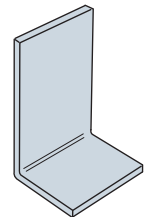
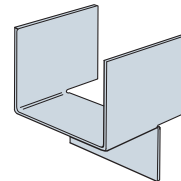
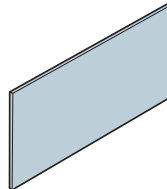
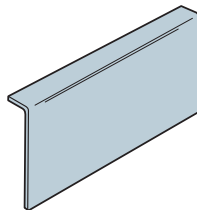
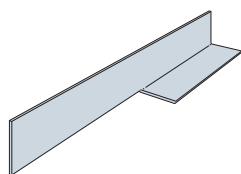
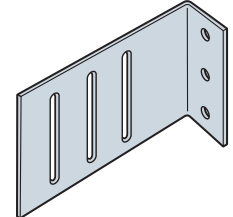
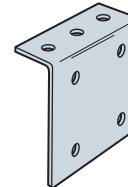
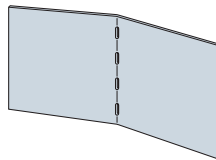
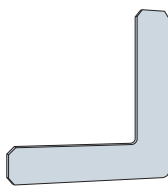
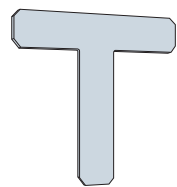
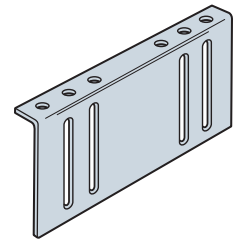

Anchor Selection Software

Anchor Selector Software™ ACI 318



Anchor Selector Software ACI 318 analyzes and suggests anchor solutions using the ACI 318, Appendix D Strength Design methodology (or CAN/CSA A23.3 Annex D Limit States Design methodology). It provides cracked and uncracked-concrete anchor solutions for numerous Simpson Strong-Tie Anchor Systems® mechanical and adhesive anchors. With its easy to use graphical interface, Anchor Selector Software ACI 318 eliminates the need for tedious calculations by hand that would otherwise be necessary to determine cracked concrete anchor solutions.



Anchor Designer™ for Allowable Stress Design



For applications where ACI 318 doesn't apply, we still have the original **Anchor Designer for Allowable Stress Design Software**. We'll continue to keep this program updated with the latest technical information so it can continue to be a valuable tool for anchor specification.

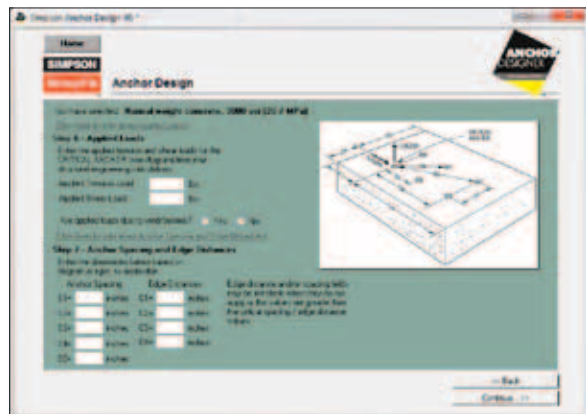

Both programs make it easy to select the correct anchorage for your application and both are available for FREE download from www.strongtie.com.

In the Specs – On the Job – At Your Service™

Home Office
5956 W. Las Positas Blvd.
Pleasanton, CA 94588
FAX: 925/847-1603

Northwest U.S.A.
5151 S. Airport Way
Stockton, CA 95206
FAX: 209/234-3868

Southwest USA
12246 Holly Street
Riverside, CA 92509
Toll Free: 800/999-5099

Northeast USA
2600 International Street
Columbus, OH 43228
Tel: 614/876-8060
Fax: 614/876-0636

Southeast USA
2221 Country Lane
McKinney, TX 75069
Tel: 972/542-0326
Fax: 972/542-5379

Kent Specials Factory
22035 W. Valley Highway
Kent, WA 98032
Toll Free: 877/564-2041

Egan Warehouse and Specials Factory
3711 Kennebec Drive
Suite 700
Egan, Minnesota 55122
Tel: 651/681-2061
Fax: 651/681-2046

Eastern Canada
5 Kenview Boulevard
Brampton, ON L6T 5G5
Tel: 905/458-5538
Fax: 905/458-7274

Western Canada
11476 Kingston Street
Maple Ridge, B.C. V2X 0Y5
Tel: 604/465-0296
Fax: 604/465-0297

Distribution Centers
Enfield, CT; High Point, NC;
Jacksonville, FL; Jessup, MD;
Langley, B.C.; Ontario, CA