

**CODE LISTED**  
ICC-ES ESR-1678  
**FOR CMU**

**CODE LISTED**  
ICC-ES ESR-2526  
**CATEGORY I**  
**CRACKED &  
UNCRACKED CONCRETE**

# Wedge-Bolt<sup>®</sup>+

## Concrete Screw Anchoring System

 **Powers**  
FASTENING INNOVATIONS



A domestic  
company  
headquartered  
in Brewster, NY

# Wedge-Bolt®+

## Screw Anchor



The Wedge-Bolt®+ anchor is a one piece, heavy duty screw anchor with a finished hex head. It is simple to install, easy to identify and fully removable. The Wedge-Bolt+ has many features and benefits that make it well suited for many applications in a variety of base materials. The anchor is designed for consistent and reliable performance in cracked and uncracked concrete, as well as grouted masonry.

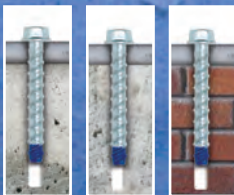

### Concrete, Block, Brick

The Wedge-Bolt®+ anchor is versatile and can be used in a variety of base materials. This reduces the need to stock assorted anchor types and learn a variety of installation procedures.



### Close to edge installation

The Wedge-Bolt®+ anchor cuts a thread into the base material. Since there are no expansion forces, the Wedge-Bolt+ anchor can be installed closer to the edge than traditional mechanical anchors without damaging the base material.



### One-piece design

The Wedge-Bolt®+ anchor is a one-piece unit which features a finished hex head formed with an integral washer, a patented dual lead thread, and a chamfered tip. A one-piece design eliminates the possibility of lost anchor parts or improper assembly.



### Loosen and Retighten

If required Wedge-Bolts can be loosened and retightened in the same hole for adjustment of the fixture. The Wedge-Bolt®+ anchor is unlike traditional wedge and sleeve anchors and requires no grinding and no anchor components are left in the hole upon removal.



### Tight Fit matches standard fixture holes

The Blue Tip Wedge-Bolt®+ anchor is designed to match standard fixture clearance holes that are 1/16" over nominal to provide a secure fit. Since the Wedge-Bolt is specially matched to the clearance hole, the need for layout or hole spotting is eliminated.



### Immediate high strength loading

The Wedge-Bolt®+ anchor can be loaded immediately. Unlike some adhesive anchors, there is no lengthy curing time. This allows for immediate completion of fastening applications.

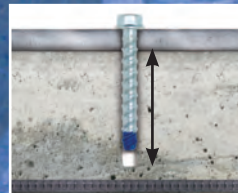

### Shallow embedment depth

The Wedge-Bolt®+ anchor can be installed at shallower embedment depths than traditional wedge or sleeve anchors reducing the chance of striking reinforcing bars or embedded cables. Drilling time and bit wear can be reduced resulting in significant savings.



### Diameter & length ID

Wedge-Bolt®+ anchors have both the diameter and length clearly embossed on the head of the anchor. This enables simple and easy inspection.



# Wedge-Bolt®+



## GENERAL APPLICATIONS AND USES

- Racking, shelving and material handling
- Support ledgers
- Interior applications/low level corrosion environment
- Temporary attachments
- Retrofits, repairs and maintenance
- Fencing and railing
- Seismic and wind loading

## FEATURES AND BENEFITS

- Consistent performance in high and low strength concrete
- Anchor can be installed through standard fixture holes
- Wedge-bit size is the same as the nominal anchor diameter
- Diameter, length and identifying marking stamped on head of each anchor
- Fast installation with a powered impact wrench
- One-piece, finished head design eliminates improper assembly or missing components

## APPROVALS AND LISTINGS

- International Code Council, Evaluation Service (ICC-ES), ESR-2526 for cracked and uncracked concrete
- International Code Council, Evaluation Service (ICC-ES), ESR-1678 for concrete masonry
- Tested in accordance with ACI 355.2 and ICC-ES AC193 for use in concrete under the design provisions of ACI 318 (Strength Design method using Appendix D)
- Evaluated and qualified by an accredited independent testing laboratory for use in cracked and uncracked concrete including seismic and wind loading (Category 1 anchors)
- Evaluated and qualified by an accredited independent testing laboratory for reliability against brittle failure, e.g. hydrogen embrittlement
- Tested in accordance with ASTM E488 and AC 106 criteria

## GUIDE SPECIFICATIONS

**CSI Divisions:** 03151-Concrete Anchoring, 04081 Masonry Anchoring and 05090-Metal Fastenings. Screw anchors shall be Wedge-Bolt+ anchors as supplied by Powers Fasteners, Inc., Brewster, NY. Anchors shall be installed in accordance with published instructions and the Authority Having Jurisdiction.

## MATERIAL SPECIFICATIONS

Anchor component	Specification
Anchor body & hex washer head	Case hardened carbon steel
Plating	Zinc plating according to ASTM B 633, SC1, Type III (Fe/Zn 5) Minimum plating requirement for Mild Service Condition
	Mechanically galvanized zinc plating according to ASTM B 695, Class 55

## ANCHOR MATERIALS

Zinc plated carbon steel body and hex washer head or mechanically galvanized carbon steel body and hex washer head

## ANCHOR SIZE RANGE (TYP.)

1/4" diameter (uncracked concrete)

3/8" through 3/4" diameter (cracked and uncracked concrete)

## SUITABLE BASE MATERIALS

Normal-weight concrete  
Structural sand-lightweight concrete  
Concrete over steel deck  
Grouted concrete masonry (CMU)  
Clay brick masonry

# Wedge-Bolt®+

## INSTALLATION SPECIFICATIONS

### Installation Table for Wedge-Bolt+ (Design Provisions of ACI 318 Appendix D)

Anchor Property/Setting Information	Notation	Units	Nominal Anchor Size							
			1/4"	3/8	1/2"	5/8	3/4"			
Nominal anchor diameter	$d_o$	in. (mm)	0.250 (6.4)	0.375 (9.5)	0.500 (12.7)	0.625 (15.9)	0.750 (19.1)			
Minimum diameter of hole clearance in fixture	$d_h$	in. (mm)	5/16 (7.9)	7/16 (11.1)	9/16 (14.3)	11/16 (17.5)	0.750 (19.1)			
Nominal drill bit diameter	$d_{bit}$	in.	1/4 Wedge-bit	3/8 Wedge-bit	1/2 Wedge-bit	5/8 Wedge-bit	3/4 Wedge-bit			
Wedge-bit tolerance range	-	in.	0.255 to 0.259	0.385 to 0.389	0.490 to 0.495	0.600 to 0.605		0.720 to 0.725		
Minimum nominal embedment depth	$h_{nom}$	in. (mm)	1-3/4 (44)	2-1/8 (54)	2-1/2 (64)	3-1/2 (89)	3-1/4 (83)	4-3/8 (111)	4-1/4 (108)	
Effective embedment	$h_{ef}$	in. (mm)	1.100 (28)	1.425 (36)	1.650 (42)	2.500 (64)	2.145 (55)	3.100 (79)	2.910 (74)	
Minimum concrete member thickness <sup>1</sup>	$h_{min}$	in. (mm)	3-1/4 (83)	1.425 (36)	5 (127)	6 (152)	6 (152)	7 (178)	7 (178)	
Critical edge distance <sup>1</sup>	$c_{ac}$	in. (mm)	2-1/2 (64)	2-3/4 (70)	3-1/4 (83)	4-1/2 (114)	4 (102)	5 (127)	5 (127)	6 (152)
Minimum edge distance <sup>1</sup>	$c_{min}$	in. (mm)	1-1/2 (38)	1-3/4 (44)	1-3/4 (44)	1-3/4 (44)	4 (102)	1-3/4 (44)	1-3/4 (44)	1-3/4 (44)
Minimum spacing distance <sup>1</sup>	$s_{min}$	in. (mm)	2 (51)	2-1/2 (64)	3-1/2 (89)	2-1/2 (64)	5 (127)	3-3/4 (95)	3 (76)	4-1/2 (114)
Minimum hole depth <sup>1</sup>	$h_o$	in. (mm)	2-1/4 (57)	2-1/2 (64)	3 (76)	4 (102)	4 (102)	5 (127)	5 (127)	
Minimum overall anchor length	$l_{anch}$	in. (mm)	2-1/4 (57)	2-1/2 (64)	3 (76)	4 (102)	4 (102)	5 (127)	5 (127)	
Maximum impact wrench power (torque)	$T_{screw}$	ft.-lb. (N-m)	115 (156)	245 (332)	300 (407)	350 (475)	400 (542)			
Impact wrench socket size	-	in.	7/16	9/16	3/4	15/16	1-1/8			
Head height	-	in.	7/32	21/64	7/16	1/2	19/32			

1. For installations through the soffit of steel deck into concrete, see the installation detail. Anchors in the lower flute may be installed with a maximum 1-inch offset in either direction from center of the flute. In addition, anchors shall have an axial spacing along the flute equal to the greater of  $3h_{ef}$  or 1.5 times the flute width.

### Wedge-Bolt+ Anchor Detail

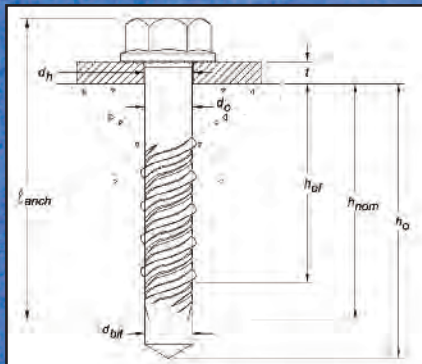

### Hex Head Marking

#### Legend

Diameter and Length Identification Mark

'+' Symbol = Strength Design Compliant Anchor

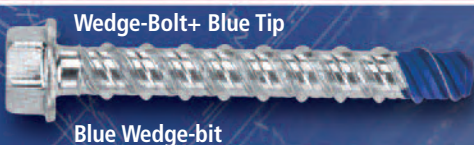

Wedge-Bolt+ Blue Tip

Blue Wedge-bit

### Matched Tolerance System

Designed & tested as a system for consistency and reliability

## INSTALLATION SPECIFICATIONS

### Installation Instructions for Wedge-Bolt+

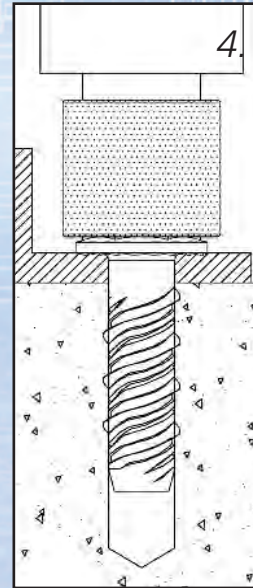
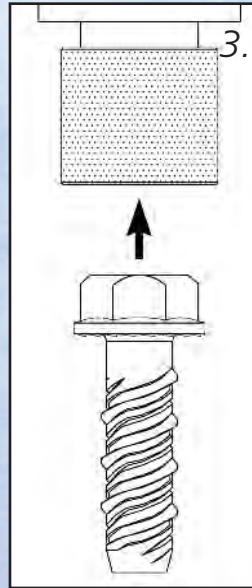
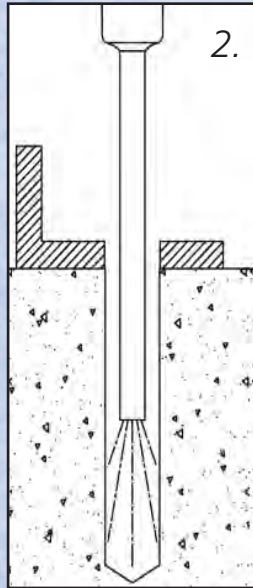
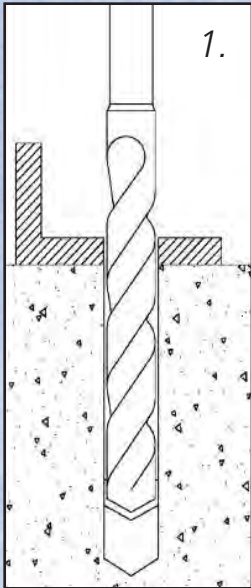

1.) Using the proper Wedge-bit size, drill a hole into the base material to the required depth. The tolerances of the carbide Wedge-bit used must meet the requirements of the published Wedge-bit range.

2.) Remove dust and debris from the hole.

3.) Select a powered impact wrench that does not exceed the maximum torque,  $T_{screw}$ , for the selected anchor diameter. Attach an appropriate sized hex socket to the impact wrench. Mount the screw anchor head into the socket.

4.) Drive the anchor through the fixture and into the hole until the head of the anchor comes into contact with the fixture. The anchor should be snug after installation. Do not spin the hex socket off the anchor to disengage.

### Installation Detail for Wedge-Bolt+ Installed Through Soffit of Steel Deck Into Concrete

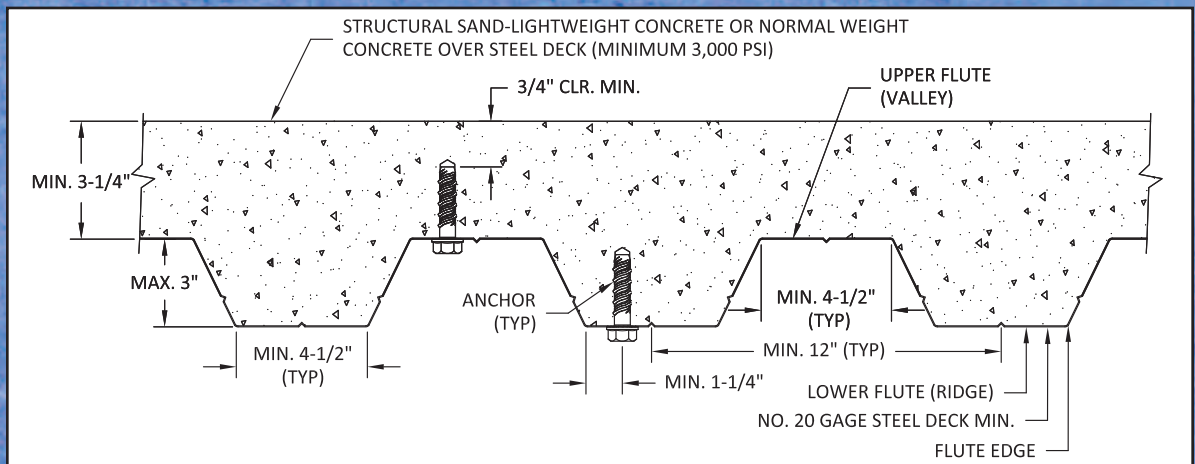

## SD PERFORMANCE DATA

### Tension Design Information (For use with load combinations taken from ACI 318 Section 9.2)<sup>1,2,3</sup>

Design Characteristic	Notation	Units	Nominal Anchor Size						
			1/4"	3/8	1/2"	5/8	3/4"		
Anchor category	1, 2 or 3	-	1	1	1	1	1	1	
Nominal embedment depth	$h_{nom}$	in.	1-3/4	2-1/8	2-1/8	3-1/2	3-1/4	3-1/4	4-1/4
<b>STEEL STRENGTH IN TENSION<sup>4</sup></b>									
Minimum specified ultimate strength	$f_{uta}$	ksi (N/mm <sup>2</sup> )	100.0 (990)	100.0 (990)	100.0 (990)	100.0 (990)	100.0 (990)	100.0 (990)	
Effective tensile stress area	$A_{se}$	in <sup>2</sup> (mm <sup>2</sup> )	0.044 (1.10)	0.044 (1.10)	0.168 (4.28)	0.249 (6.41)	0.249 (6.41)	0.371 (9.53)	
Steel strength in tension	$N_{sa}$	lb (kN)	4,400 (19.6)	10,300 (45.8)	16,800 (74.7)	24,900 (110.7)	24,900 (110.7)	37,100 (164.9)	
Reduction factor for steel strength <sup>3</sup>	$\phi$	-	0.65						
<b>CONCRETE BREAKOUT STRENGTH IN TENSION<sup>9</sup></b>									
Effective embedment	$h_{ef}$	in. (mm)	1.100 (28)	1.425 (36)	1.650 (42)	2.500 (64)	2.145 (54)	3.100 (79)	2.910 (74)
Effectiveness factor for uncracked concrete	$k_{uncr}$	-	24	24	24	24	24	24	24
Effectiveness factor for cracked concrete	$k_{cr}$	-	-	17	17	17	17	17	17
Modification factor for cracked and uncracked concrete <sup>5</sup>	$\psi_{c,N}$	-	1.0 See note 5	1.0 See note 5	1.0 See note 5	1.0 See note 5	1.0 See note 5	1.0 See note 5	1.0 See note 5
Critical edge distance	$c_{ac}$	in. (mm)	2-1/2 (64)	2-3/4 (70)	3-1/4 (83)	4-1/2 (114)	4 (102)	5 (127)	6 (152)
Reduction factor for concrete breakout strength <sup>3</sup>	$\phi$	-	Condition B = 0.65						
<b>PULLOUT STRENGTH IN TENSION (NON-SEISMIC APPLICATIONS)<sup>9</sup></b>									
Characteristic pullout strength, uncracked concrete (2,500 psi) <sup>6</sup>	$N_{p,uncr}$	lb (kN)	See note 7	See note 7	See note 7	See note 7	See note 7	See note 7	See note 7
Characteristic pullout strength, cracked concrete (2,500 psi) <sup>6</sup>	$N_{p,cr}$	lb (kN)	No data	See note 7	See note 7	2,965 (13.2)	3,085 (13.7)	4,290 (19.1)	See note 7
Reduction factor for pullout strength <sup>3</sup>	$\phi$	-	Condition B = 0.65						
<b>PULLOUT STRENGTH IN TENSION FOR SEISMIC APPLICATIONS<sup>9</sup></b>									
Characteristic pullout strength, seismic <sup>6,9</sup>	$N_{eq}^{11}$	lb (kN)	No data	1,085 (4.8)	1,350 (6.0)	2,520 (11.2)	3,085 (13.7)	4,290 (19.1)	4,270 (19.0)
Reduction factor for pullout strength <sup>3</sup>	$\phi$	-	Condition B = 0.65						
<b>PULLOUT STRENGTH IN TENSION FOR STRUCTURAL SAND-LIGHTWEIGHT AND NORMAL-WEIGHT CONCRETE OVER STEEL DECK</b>									
Characteristic pullout strength, uncracked concrete over steel deck <sup>10</sup>	$N_{p,deck,uncr}$	lb (kN)	N/A	2,010 (8.9)	2,480 (11.0)	3,760 (16.7)	4,095 (18.2)	4,095 (18.2)	N/A
Characteristic pullout strength, cracked concrete over steel deck <sup>10</sup>	$N_{p,deck,cr}$	lb (kN)	N/A	1,425 (6.3)	1,755 (7.8)	3,045 (13.5)	2,665 (11.9)	2,665 (11.9)	N/A
Reduction factor for pullout strength <sup>3</sup>	$\phi$	-	Condition B = 0.65						

- The data in this table is intended to be used with the design provisions of ACI 318 Appendix D; for anchors resisting seismic load combinations the additional requirements of Section D.3.3 shall apply.
- Installation must comply with published instructions and details.
- All values of  $\phi$  were determined from the load combinations of ACI 318 Section 9.2. If the load combinations of Appendix C are used, the appropriate value of  $\phi$  must be determined in accordance with ACI 318 Section D.4.5. For reinforcement that meets ACI 318 Appendix D requirements for Condition A, see ACI 318 Section D.4.4 for the appropriate  $\phi$  factor.
- The Wedge-Bolt+ is considered a brittle steel element as defined by ACI 318 Section D.1.
- For all design cases use  $\psi_{c,N} = 1.0$ . Select appropriate effectiveness factor for cracked concrete ( $k_{cr}$ ) or uncracked concrete ( $k_{uncr}$ ).
- For all design cases use  $\psi_{c,N} = 1.0$ . For concrete compressive strength greater than 2,500 psi,  $N_{pn} = (\text{pullout strength value from table}) * (\text{specified concrete compressive strength}/2500)^{0.5}$ .
- Pullout strength will not control design of indicated anchors. Do not calculate pullout strength for indicated anchor size and embedment.
- Reported values for characteristic pullout strength in tension for seismic applications are based on test results per ACI 355.2, Section 9.5.
- Anchors are permitted to be used in structural sand-lightweight concrete provided that  $N_b$  and  $N_{pn}$  are multiplied by a factor of 0.60 (not required for steel deck).
- Values for  $N_{p,deck}$  are for structural sand-lightweight concrete ( $f'_{c,min} = 3,000$  psi) and additional lightweight concrete reduction factors need not be applied. In addition, evaluation for the concrete breakout capacity in accordance with ACI 318 Section D.5.2 is not required for anchors installed in the flute (soffit);
- For 2003 IBC code basis, replace  $F_{uta}$  with  $F_{Ut}$ ; and  $N_{sa}$  with  $N_s$ ;  $\psi_{c,N}$  with  $\psi_s$  and  $N_{ca}$  with  $N_{0,seis}$ .

## SD PERFORMANCE DATA

### Shear Design Information (For use with load combinations taken from ACI 318 Section 9.2)<sup>1,2,3</sup>

Design Characteristic	Notation	Units	Nominal Anchor Size						
			1/4"	3/8	1/2"	5/8	3/4"		
Anchor category	1, 2 or 3	-	1	1	1	1	1		
Nominal embedment depth	$h_{nom}$	in.	1-3/4	2-1/8	2-1/8	3-1/2	3-1/4	3-1/4	4-1/4
<b>STEEL STRENGTH IN SHEAR<sup>4</sup></b>									
Minimum specified ultimate strength	$V_{sa}$	lb (kN)	2,475 (11.0)	2,475 (11.0)	7,980 (35.4)	11,990 (53.3)	19,350 (86.1)		
Reduction factor for steel strength <sup>3</sup>	$\phi$	-	0.60						
<b>CONCRETE BREAKOUT STRENGTH IN SHEAR<sup>9</sup></b>									
Effective embedment	$e$	in. (mm)	1.100 (28)	1.425 (36)	1.650 (42)	2.500 (64)	2.145 (54)	3.100 (79)	2.910 (74)
Reduction factor for concrete breakout strength <sup>3</sup>	$\phi$	-	Condition B = 0.70						
<b>PRYOUT STRENGTH IN SHEAR<sup>6</sup></b>									
Characteristic pullout strength, uncracked concrete (2,500 psi) <sup>6</sup>	$k_{cp}$	-	1.0	1.0	1.0	2.0	1.0	2.0	2.0
Characteristic pullout strength, cracked concrete (2,500 psi) <sup>6</sup>	$h_{ef}$	in. (mm)	1.100 (28)	1.425 (36)	1.650 (42)	2.500 (64)	2.145 (54)	3.100 (79)	2.910 (74)
Reduction factor for pullout strength <sup>3</sup>	$\phi$	-	Condition B = 0.70						
<b>STEEL STRENGTH IN SHEAR FOR SEISMIC APPLICATIONS<sup>7</sup></b>									
Characteristic pullout strength, seismic <sup>6,9</sup>	$V_{eq}^{10}$	lb (kN)	No data	3,670 (16.3)	3,670 (16.3)	11,990 (53.3)	12,970 (57.7)		
Reduction factor for pullout strength <sup>3</sup>	$\phi$	-	Condition B = 0.60						
<b>STEEL STRENGTH IN SHEAR FOR STRUCTURAL SAND-LIGHTWEIGHT AND NORMAL-WEIGHT CONCRETE OVER STEEL DECK<sup>9</sup></b>									
Characteristic pullout strength, uncracked concrete over steel deck <sup>10</sup>	$V_{sa,deck}$	lb (kN)	No data	1,640 (7.3)	3,090 (13.7)	3,140 (14.0)	3,305 (14.7)	-	
Reduction factor for pullout strength <sup>3</sup>	$\phi$	-	Condition B = 0.60						

- The data in this table is intended to be used with the design provisions of ACI 318 Appendix D; for anchors resisting seismic load combinations the additional requirements of Section D.3.3 shall apply.
- Installation must comply with published instructions and details.
- All values of  $\phi$  were determined from the load combinations of ACI 318 Section 9.2. If the load combinations of Appendix C are used, the appropriate value of  $\phi$  must be determined in accordance with ACI 318 Section D.4.5. For reinforcement that meets ACI 318 Appendix D requirements for Condition A, see ACI 318 Section D.4.4 for the appropriate  $\phi$  factor.
- The Wedge-Bolt+ is considered a brittle steel element as defined by ACI 318 Section D.1.
- Reported values for steel strength in shear are based on test results per ACI 355.2, Section 9.4 and shall be used for design. These reported values may be lower than calculated results using Equation D-20 in ACI 318-05 Section D.6.1.2 and D-18 in ACI 318-02, Section D.6.1.2.
- Anchors are permitted to be used in structural sand-lightweight concrete provided that  $V_b$  and  $V_{cp}$  are multiplied by a factor of 0.60 (not required for steel deck).
- Reported values for steel strength in shear for seismic applications are based on test results per ACI 355.2, Section 9.6.
- Values for  $V_{sa,deck}$  are for structural sand-lightweight concrete ( $f'_c, min = 3,000$  psi) and additional lightweight concrete concrete reduction factors need not be applied. In addition, evaluation for the concrete breakout capacity in accordance with ACI 318 Section D.6.2 and the pryout capacity in accordance with Section D.6.3 are not required for anchors installed in the flute (soffit).
- Shear loads for anchors installed through steel deck into concrete may be applied in any direction.
- For 2003 IBC code basis, replace  $V_{sa}$  with  $V_s$ ; and  $\ell_e$  with  $\ell$  and  $V_{eq}$  with  $V_{sa,seis}$ .



# Wedge-Bolt®+



## FACTORED RESISTANCE STRENGTH ( $\phi N_n$ AND $\phi V_n$ ) CALCULATED IN ACCORDANCE WITH APPENDIX D:

- Tabular values are provided for illustration and are applicable for single anchors installed in normal-weight concrete with minimum slab thickness,  $h_a = h_{min}$ , and with the following conditions:
  - $c_{a1}$  is greater than or equal to the critical edge distance,  $c_{ac}$  (table values based on  $c_{a1} = c_{ac}$ ).
  - $c_{a2}$  is greater than or equal to 1.5 times  $c_{a1}$ .
- Calculations were performed according to ACI 318-05 Appendix D. The load level corresponding to the controlling failure mode is listed. (e.g. For *tension*: steel, concrete breakout and pullout; For *shear*: steel, concrete breakout and pryout). Furthermore, the capacities for concrete breakout strength in tension and pryout strength in shear are calculated using the effective embedment values,  $h_{ef}$ , for the selected anchors as noted in the design information tables. Please also reference the installation specifications for more information.
- Strength reduction factors ( $\phi$ ) were based on ACI 318 Section 9.2 for load combinations. Condition B is assumed.
- Tabular values are permitted for static loads only, seismic loading is not permitted with these tables.
- For designs that include combined tension and shear, the interaction of tension and shear loads must be calculated in accordance with ACI 318 Appendix D.
- Interpolation is not permitted to be used with the tabular values. For intermediate base material compressive strengths please see ACI 318 Appendix D. For other design conditions including seismic considerations please see ACI 318 Appendix D.

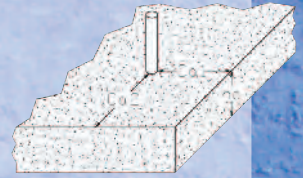

### Tension and Shear Factored Resistance Strength for Wedge-Bolt+ in Cracked Concrete

Nominal Anchor Size (in.)	Nominal Embed. h <sub>nom</sub> (in.)	Minimum Concrete Compressive Strength, f'c (psi)									
		2,500		3,000		4,000		6,000		8,000	
		$\phi N_n$ Tension (lbs.)	$\phi V_n$ Shear (lbs.)	$\phi N_n$ Tension (lbs.)	$\phi V_n$ Shear (lbs.)	$\phi N_n$ Tension (lbs.)	$\phi V_n$ Shear (lbs.)	$\phi N_n$ Tension (lbs.)	$\phi V_n$ Shear (lbs.)	$\phi N_n$ Tension (lbs.)	$\phi V_n$ Shear (lbs.)
1/4	1-3/4	-	-	-	-	-	-	-	-	-	-
3/8	2-1/8	940	940	1,030	1,030	1,190	1,190	1,460	1,460	1,685	1,685
1/2	2-1/2	1,175	1,145	1,285	1,250	1,485	1,445	1,815	1,770	2,100	2,045
	3-1/2	1,925	1,915	2,110	2,095	2,440	2,420	2,985	2,965	3,450	3,420
5/8	3-1/4	1,735	1,870	1,905	2,050	2,195	2,365	2,690	2,900	3,105	3,345
	4-3/8	2,790	2,785	3,055	3,050	3,525	3,520	4,320	4,325	4,990	4,980
3/4	4-1/4	2,740	3,180	3,005	3,485	3,465	4,025	4,245	4,925	4,905	5,690

### Tension and Shear Factored Resistance Strength for Wedge-Bolt+ in Uncracked Concrete

Nominal Anchor Size (in.)	Nominal Embed. h <sub>nom</sub> (in.)	Minimum Concrete Compressive Strength, f'c (psi)									
		2,500		3,000		4,000		6,000		8,000	
		$\phi N_n$ Tension (lbs.)	$\phi V_n$ Shear (lbs.)	$\phi N_n$ Tension (lbs.)	$\phi V_n$ Shear (lbs.)	$\phi N_n$ Tension (lbs.)	$\phi V_n$ Shear (lbs.)	$\phi N_n$ Tension (lbs.)	$\phi V_n$ Shear (lbs.)	$\phi N_n$ Tension (lbs.)	$\phi V_n$ Shear (lbs.)
1/4	1-3/4	900	970	985	1,060	1,140	1,225	1,395	1,485	1,610	1,485
3/8	2-1/8	1,330	1,320	1,455	1,445	1,680	1,670	2,060	2,045	2,375	2,360
1/2	2-1/2	1,655	1,600	1,815	1,755	2,095	2,025	2,565	2,480	2,965	2,865
	3-1/2	3,085	2,680	3,380	2,935	3,905	3,385	4,780	4,150	5,520	4,780
5/8	3-1/4	2,450	2,680	3,380	2,895	3,100	3,340	3,800	4,090	4,385	4,725
	4-3/8	4,260	3,900	3,380	4,270	5,390	4,930	6,600	6,040	7,625	6,975
3/4	4-1/4	3,870	4,455	4,240	4,880	4,895	5,635	5,995	6,900	6,925	7,965

#### Legend

- Anchor Pullout/Pryout Strength Controls
- Concrete Breakout Strength Controls
- Steel Strength Controls



### FACTORED RESISTANCE STRENGTH ( $\phi N_n$ AND $\phi V_n$ ) CALCULATED IN ACCORDANCE WITH APPENDIX D:

- Tabular values are provided for illustration and are applicable for single anchors installed in normal-weight concrete with minimum slab thickness,  $h_a = h_{min}$ , and with the following conditions:
  - $c_{a1}$  is greater than or equal to the critical edge distance,  $c_{ac}$  (table values based on  $c_{a1} = c_{ac}$ ).
  - $c_{a2}$  is greater than or equal to 1.5 times  $c_{a1}$ .
- Calculations were performed according to ACI 318-05 Appendix D. The load level corresponding to the controlling failure mode is listed. (e.g. For *tension*: steel, concrete breakout and pullout; For *shear*: steel, concrete breakout and pryout). Furthermore, the capacities for concrete breakout strength in tension and pryout strength in shear are calculated using the effective embedment values,  $h_{ef}$ , for the selected anchors as noted in the design information tables. Please also reference the installation specifications for more information.
- Strength reduction factors ( $\phi$ ) were based on ACI 318 Section 9.2 for load combinations. Condition B is assumed.
- Tabular values are permitted for static loads only, seismic loading is not considered with these tables.
- For designs that include combined tension and shear, the interaction of tension and shear loads must be calculated in accordance with ACI 318 Appendix D.
- Interpolation is not permitted to be used with the tabular values. For intermediate base material compressive strengths please see ACI 318 Appendix D. For other design conditions including seismic considerations please see ACI 318 Appendix D.

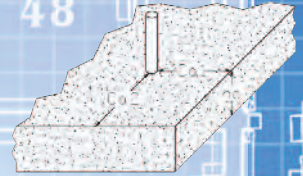

### Tension and Shear Design Strength with 1-3/4" Edge Distance for Wedge-Bolt+ in Cracked Concrete

Nominal Anchor Size (in.)	Nominal Embed. $h_{nom}$ (in.)	Minimum Concrete Compressive Strength, $f'_c$ (psi)									
		2,500		3,000		4,000		6,000		8,000	
		$\phi N_n$ Tension (lbs.)	$\phi V_n$ Shear (lbs.)	$\phi N_n$ Tension (lbs.)	$\phi V_n$ Shear (lbs.)	$\phi N_n$ Tension (lbs.)	$\phi V_n$ Shear (lbs.)	$\phi N_n$ Tension (lbs.)	$\phi V_n$ Shear (lbs.)	$\phi N_n$ Tension (lbs.)	$\phi V_n$ Shear (lbs.)
1/4	1-3/4	-	-	-	-	-	-	-	-	-	-
3/8	2-1/8	395	455	435	495	500	575	615	705	710	810
1/2	2-1/2	400	510	440	560	505	645	620	790	715	910
	3-1/2	425	555	465	605	535	700	655	855	760	990
5/8	3-1/4	415	575	450	630	520	725	640	890	740	1025
	4-3/8	445	620	490	675	565	780	690	955	795	1105
3/4	4-1/4	440	645	480	705	555	815	680	1000	785	1150

### Tension and Shear Design Strength with 1-3/4" Edge Distance for Wedge-Bolt+ in Uncracked Concrete

Nominal Anchor Size (in.)	Nominal Embed. $h_{nom}$ (in.)	Minimum Concrete Compressive Strength, $f'_c$ (psi)									
		2,500		3,000		4,000		6,000		8,000	
		$\phi N_n$ Tension (lbs.)	$\phi V_n$ Shear (lbs.)	$\phi N_n$ Tension (lbs.)	$\phi V_n$ Shear (lbs.)	$\phi N_n$ Tension (lbs.)	$\phi V_n$ Shear (lbs.)	$\phi N_n$ Tension (lbs.)	$\phi V_n$ Shear (lbs.)	$\phi N_n$ Tension (lbs.)	$\phi V_n$ Shear (lbs.)
1/4	1-3/4	390	535	425	585	490	675	600	825	695	955
3/8	2-1/8	435	635	475	695	550	805	675	985	780	1,135
1/2	2-1/2	430	715	470	780	545	900	665	1,105	770	1,275
	3-1/2	560	775	545	850	630	980	775	1,200	895	1,385
5/8	3-1/4	500	805	640	880	735	1,015	900	1,245	1,140	1,435
	4-3/8	585	865	640	945	740	1,095	905	1,340	1,145	1,545
3/4	4-1/4	450	900	495	990	570	1,140	695	1,395	805	1,615

Concrete Breakout Strength Controls



### ASD PERFORMANCE DATA

#### Ultimate Load Capacities for Wedge-Bolt+ Installed into Normal-Weight Concrete at Critical Spacing and Edge Distances<sup>1,2,3</sup>

Anchor Diameter in. (mm)	Minimum Embedment Depth in. (mm)	Minimum Concrete Compressive Strength (f'c)					
		2,000 psi (13.8 Mpa)		4,000 psi (27.6 Mpa)		6,000 psi (41.4 Mpa)	
		Tension lbs. (kN)	Shear lbs. (kN)	Tension lbs. (kN)	Shear lbs. (kN)	Tension lbs. (kN)	Shear lbs. (kN)
1/4 (6.4)	1 (25.4)	720 (3.2)	920 (4.0)	1,340 (6.0)	1,880 (8.3)	1,660 (7.5)	2,160 (9.6)
	1-1/2 (38.1)	1,440 (6.5)	2,000 (8.8)	2,140 (9.6)	2,080 (9.2)	2,480 (11.2)	2,260 (10.0)
	2 (50.8)	2,400 (10.8)	2,000 (8.8)	3,940 (17.7)	2,080 (9.2)	4,980 (22.4)	2,680 (11.9)
	2-1/2 (63.5)	3,520 (15.8)	2,000 (8.8)	4,660 (21.0)	2,080 (9.2)	5,260 (23.7)	2,680 (11.9)
3/8 (9.5)	1-1/2 (38.1)	1,900 (8.6)	2,760 (12.2)	2,520 (11.3)	3,440 (15.3)	3,040 (13.7)	5,600 (24.9)
	2 (50.8)	3,000 (13.5)	3,100 (13.7)	3,920 (17.6)	3,440 (15.3)	5,200 (23.4)	5,600 (24.9)
	2-1/2 (63.5)	4,100 (18.5)	3,440 (15.3)	5,320 (23.9)	3,440 (15.3)	7,340 (33.0)	5,600 (24.9)
	3 (76.2)	5,800 (26.1)	4,120 (18.3)	7,740 (34.8)	4,320 (19.2)	9,900 (44.6)	5,600 (24.9)
	3-1/2 (88.9)	7,500 (33.8)	4,820 (21.4)	10,140 (45.6)	5,200 (23.1)	12,440 (56.0)	5,600 (24.9)
1/2 (12.7)	2 (50.8)	2,860 (12.9)	4,960 (22.0)	3,940 (17.7)	5,680 (25.2)	4,780 (21.5)	7,600 (33.8)
	2-1/2 (63.5)	4,100 (18.5)	5,800 (25.8)	5,200 (23.4)	6,480 (28.8)	6,480 (28.8)	7,960 (35.4)
	3 (76.2)	5,920 (26.6)	6,200 (27.5)	7,800 (35.1)	7,240 (32.2)	9,380 (42.2)	7,960 (35.4)
	3-1/2 (88.9)	6,060 (27.3)	8,020 (35.6)	8,480 (38.2)	8,160 (36.2)	11,900 (53.6)	8,600 (38.2)
	4 (101.6)	7,560 (34.0)	8,660 (39.0)	12,620 (56.8)	9,080 (40.9)	12,620 (56.8)	9,600 (43.2)
5/8 (15.9)	2-1/2 (63.5)	3,420 (15.4)	7,200 (32.4)	4,720 (21.2)	10,240 (45.5)	6,900 (31.1)	10,180 (45.2)
	3 (76.2)	4,560 (20.5)	7,920 (35.2)	7,380 (33.2)	10,240 (45.5)	8,960 (40.3)	11,400 (50.7)
	3-1/2 (88.9)	5,720 (25.7)	8,640 (38.4)	10,040 (45.2)	10,240 (45.5)	11,040 (49.7)	11,400 (50.7)
	4 (101.6)	8,240 (37.1)	9,540 (42.4)	12,760 (57.4)	11,140 (49.5)	14,320 (64.4)	12,080 (53.7)
	4-1/2 (114.3)	10,780 (48.5)	10,460 (46.5)	15,500 (69.8)	12,040 (53.5)	17,600 (79.2)	12,760 (56.7)
	5 (127.0)	13,300 (59.9)	11,360 (50.5)	18,220 (82.0)	12,960 (57.6)	20,860 (93.9)	13,480 (59.9)
3/4 (19.1)	3 (76.2)	4,320 (19.4)	9,480 (42.1)	6,480 (29.2)	12,120 (53.9)	8,700 (39.2)	14,800 (65.8)
	3-1/2 (88.9)	5,720 (25.7)	10,460 (46.5)	9,320 (41.9)	14,820 (65.9)	11,360 (51.1)	16,400 (72.9)
	4 (101.6)	7,120 (32.0)	11,460 (50.9)	12,140 (54.6)	17,520 (77.9)	14,020 (63.1)	18,000 (80.0)
	4-1/2 (114.3)	9,240 (41.6)	13,120 (58.3)	13,580 (61.1)	18,660 (83.0)	16,720 (75.2)	19,840 (88.2)
	5 (127.0)	11,340 (51.0)	14,780 (65.7)	15,020 (67.6)	19,740 (89.8)	19,400 (87.3)	21,700 (96.5)
	5-1/2 (139.7)	13,440 (60.5)	16,640 (74.0)	16,460 (74.1)	20,840 (92.7)	22,080 (99.4)	23,560 (104.8)
	6 (152.4)	15,540 (69.9)	18,120 (80.6)	17,900 (80.6)	21,960 (97.6)	24,760 (111.4)	25,420 (113.0)

1. Tabulated load values are for anchors installed in concrete. Concrete compressive strength must be at the specified minimum at the time of installation.
2. Ultimate load capacities must be reduced by a minimum safety factor of 4.0 or greater to determine allowable working load.
3. Allowable load capacities are multiplied by reduction factors found in the Design Criteria section when anchor spacing or edge distances are less than critical distances.



# Ultimate & Allowable Load Tables

## ASD PERFORMANCE DATA

### Ultimate and Allowable Shear Load Capacities for Wedge-Bolt+ at 1-3/4" Edge of Normal-Weight Concrete<sup>1,2</sup>

Nominal Anchor Dia. <i>d</i> in. (mm)	Min. Embed. Depth <i>h<sub>v</sub></i> in. (mm)	Min. Edge Distance <i>h<sub>v</sub></i> in. (mm)	<i>f<sub>c</sub></i> ≥ 2,000 psi (17.2 MPa)	
			Parallel to the Free Edge	Toward the Free Edge
			Ultimate Shear lbs. (kN)	Allowable Shear lbs. (kN)
1/2 (12.7)	3-3/8 (85.7)	1-3/4 (44.5)	5,020 (22.6)	1,255 (5.6)
5/8 (15.9)	3-3/8 (85.7)	1-3/4 (44.5)	5,420 (24.4)	1,355 (6.1)
3/4 (19.1)	3-3/8 (85.7)	1-3/4 (44.5)	5,660 (25.5)	1,415 (6.4)

1. Tabulated load values are for anchors installed in concrete. Concrete compressive strength must be at the specified minimum at the time of installation.
2. Allowable load capacities are calculated using an applied safety factor of 4.0

### Ultimate and Allowable Tension Load Capacities for Wedge-Bolt+ Installed at 1-3/4" Edge of Normal-Weight Concrete<sup>1,2</sup>

Nominal Anchor Dia. <i>d</i> in. (mm)	Min. Embed. Depth <i>h<sub>v</sub></i> in. (mm)	Min. Edge Distance <i>h<sub>v</sub></i> in. (mm)	Minimum Concrete Compressive Strength, <i>f<sub>c</sub></i>					
			2,500 (17.2 MPa)		3,000 (20.7 MPa)		4,000 (27.6 MPa)	
			Ultimate Tension lbs. (kN)	Allowable Tension lbs. (kN)	Ultimate Tension lbs. (kN)	Allowable Tension lbs. (kN)	Ultimate Tension lbs. (kN)	Allowable Tension lbs. (kN)
5/8 (15.9)	8 (203.2)	1-3/4 (44.5)	15,630 (70.3)	3,910 (17.6)	16,630 (74.8)	4,160 (18.7)	18,150 (81.7)	4,540 (20.4)
	9 (228.6)		16,995 (76.5)	4,250 (19.1)	18,185 (81.8)	4,545 (20.5)	18,185 (81.8)	4,955 (22.3)

1. Tabulated load values are for anchors installed in concrete. Concrete compressive strength must be at the specified minimum at the time of installation.
2. Allowable load capacities are calculated using an applied safety factor of 4.0
3. Linear interpolation may be used to determine allowable loads for intermediate embedments and compressive strength.

### Allowable Load Capacities for Wedge-Bolt+ Installed at 1-3/4" Edge of Normal-Weight Concrete Stem Walls<sup>1,2,3</sup>

Nominal Anchor Dia. <i>d</i> in. (mm)	Min. Embed. Depth <i>h<sub>v</sub></i> in. (mm)	Min. Edge Distance <i>h<sub>v</sub></i> in. (mm)	<i>f<sub>c</sub></i> ≥ 2,500 psi (17.2 MPa)		
				Parallel to the Free Edge	Toward the Free Edge
			Tension lbs. (kN)	Shear lbs. (kN)	Shear lbs. (kN)
1/2 (12.7)	4 (101.6)	1-3/4 (44.5)	1,270 (5.67)	1,425 (6.4)	470 (2.1)
5/8 (15.9)	2 1/2 (63.5)	1-3/4 (44.5)	610 (2.7)	1,155 (5.2)	380 (1.7)
	3 3/4 (95.3)		1,310 (5.9)	1,330 (6.0)	490 (2.2)
	5 (127.0)		2,015 (9.1)	1,505 (6.8)	600 (2.7)

1. Tabulated load values are for anchors installed in concrete. Concrete compressive strength must be at the specified minimum at the time of installation.
2. Allowable load capacities are calculated using an applied safety factor of 4.0.
3. Allowable load capacities may also be applied to conditions at the edge of normal-weight concrete slabs.

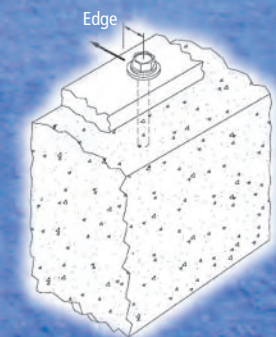
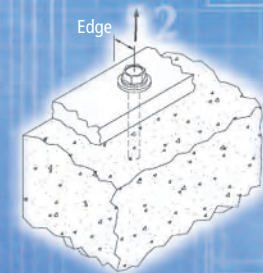
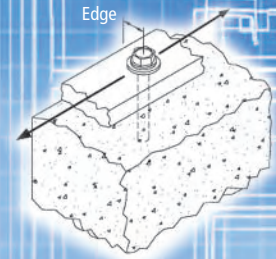

# Wedge-Bolt®+

## Allowable Load Table



### MASONRY PERFORMANCE DATA

#### Allowable Load Capacities for Wedge-Bolt+ Anchors Installed into the Face of Grout Filled Concrete Masonry<sup>1,2,3,4</sup>

Anchor Diameter d (in.) (mm)	Minimum Embed. hv (in.) (mm)	Minimum Edge Distance (in.) (mm)	Minimum End Distance (in.) (mm)	Tension lbs. (kN)		Shear lbs. (kN)	
				f'm = 1,500 psi	f'm ≥ 2,000 psi	f'm = 1,500 psi	f'm ≥ 2,000 psi
1/4 (6.4)	1 (25.4)	3-3/4 (95.3)	3-3/4 (95.3)	80 (0.4)	80 (0.4)	150 (0.7)	150 (0.7)
	2 (50.8)	1-1/2 (38.1)	2-3/4 (69.9)	230 (1.0)	265 (1.2)	165 (0.7)	190 (0.8)
	2 (50.8)	3-3/4 (95.3)	3-3/4 (95.3)	340 (1.5)	340 (1.5)	340 (1.5)	340 (1.5)
3/8 (9.5)	1-1/2 (38.1)	3-3/4 (95.3)	12 (304.8)	210 (0.9)	210 (0.9)	400 (1.8)	400 (1.8)
	2-1/2 (63.5)	1-3/4 (44.5)	3-3/4 (95.3)	295 (1.3)	340 (1.5)	210 (0.9)	245 (1.1)
	2-1/2 (63.5)	7-7/8 (200.0)	12 (304.8)	750 (3.4)	750 (3.4)	655 (2.9)	655 (2.9)
	2-1/2 (63.5)	12 (304.8)		615 (2.7)	710 (3.1)	915 (4.0)	1055 (4.7)
	3-1/2 (88.9)	12 (304.8)	12 (304.8)	1,290 (5.8)	1,290 (5.8)	910 (4.0)	910 (4.0)
1/2 (12.7)	2 (50.8)	3-3/4 (95.3)	12 (304.8)	335 (1.5)	335 (1.5)	720 (3.2)	720 (3.2)
	3 (76.2)	7-7/8 (200.0)		930 (4.2)	930 (4.2)	900 (4.0)	900 (4.0)
	3-1/2 (88.9)	2-3/4 (69.9)	3-3/4 (95.3)	595 (2.6)	685 (3.0)	405 (1.8)	470 (2.1)
	4 (101.6)	12 (304.8)	12 (304.8)	1,525 (6.9)	1,525 (6.9)	1,085 (4.8)	1,085 (4.8)
5/8 (15.9)	2-1/2 (63.5)	3-3/4 (95.3)	12 (304.8)	455 (2.0)	455 (2.0)	1,085 (4.8)	1,085 (4.8)
	3 1/4 (101.6)	7-7/8 (200.0)		885 (4.0)	885 (4.0)	1,085 (4.8)	1,085 (4.8)
	4 (101.6)	12 (304.8)		1,310 (5.9)	1,310 (5.9)		
	5 (127.0)			1,940 (8.7)	1,940 (8.7)	1,255 (5.6)	1,255 (5.6)
3/4 (19.1)	3 (76.2)	3-3/4 (95.3)	12 (304.8)	615 (2.8)	615 (2.8)	750 (3.4)	750 (3.4)
		12 (304.8)		615 (2.8)	615 (2.8)	1,320 (5.9)	1,320 (5.9)
	3-1/2 (88.9)	7-7/8 (200.0)		1,035 (4.7)	1,035 (4.7)	1,265 (5.7)	1,265 (5.7)
	4 (101.6)	12 (304.8)		1,455 (6.5)	1,455 (6.5)	1,320 (5.9)	1,320 (5.9)
	5 (127.0)			1,680 (7.6)	1,680 (7.6)	1,775 (7.9)	1,775 (7.9)

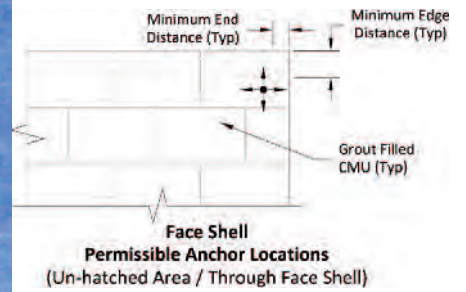

1. Tabulated load values are for anchors installed in minimum 6" wide, Grade N, Type II, lightweight concrete masonry units conforming to ASTM C 90 that have reached the minimum designated ultimate compressive strength at the time of installation (f'm ≥ 1,500 psi).
2. Allowable load capacities listed are calculated using an applied safety factor of 5.0. Consideration of safety factors of 10 or higher may be necessary depending on the application, such as life safety or overhead.
3. Linear interpolation for allowable loads for anchors at intermediate embedment depths may be used.
4. Allowable shear loads for 1/4" and 3/8" diameter anchor installations into the face shell of a masonry wall may be applied in any direction. Allowable shear loads for anchor diameters 1/2" and greater installed into the face shell may be applied in any direction provided the location is a minimum of 12" from the edge of the wall. For anchor diameters 1/2" and greater installed with an edge distance less than 12" the allowable shear loads may be applied in any direction except upward vertically.





**MASONRY PERFORMANCE DATA**

**Allowable Load Capacities for Wedge-Bolt+ Anchors Installed into the Top of Grout-Filled Concrete Masonry Wall<sup>1,2</sup>**

Nom. Anchor Diameter <i>d</i> in. (mm)	Min. Embed. Depth <i>h<sub>v</sub></i> in. (mm)	Minimum Edge Distance in. (mm)	Minimum End Distance in. (mm)	Tension lbs. (kN)		Shear (Toward Edge of Wall) lbs. (kN)		Shear (Toward End of Wall) lbs. (kN)	
				<i>f</i> 'm = 1,500 psi	<i>f</i> 'm ≥ 2,000 psi	<i>f</i> 'm = 1,500 psi	<i>f</i> 'm ≥ 2,000 psi	<i>f</i> 'm = 1,500 psi	<i>f</i> 'm ≥ 2,000 psi
3/8 (9.5)	2-1/2 (63.5)	1-1/2 (38.1)	3 (76.2)	310 (1.4)	355 (1.6)	140 (0.6)	160 (0.7)	250 (1.1)	290 (1.3)
	1-1/2 (38.1)	2 (50.8)	-	-	-	350 (1.6)	350 (1.6)	350 (1.6)	350 (1.6)
	2-1/2 (63.5)		-	570 (2.5)	570 (2.5)	380 (1.7)	380 (1.7)	380 (1.7)	380 (1.7)
1/2 (12.7)	3-1/2 (88.9)	1-3/4 (44.5)	3 (76.2)	535 (2.4)	620 (2.7)	260 (1.2)	305 (1.3)	240 (1.1)	275 (1.2)
	4-1/2 (114.3)	1-3/4 (44.5)	3 (76.2)	745 (3.3)	860 (3.8)	-	-	-	-
5/8 (15.9)	4-1/2 (114.3)	1-3/4 (44.5)	9 (228.6)	835 (3.7)	965 (4.3)	250 (1.1)	285 (1.2)	575 (2.6)	660 (2.9)
	5-1/2 (139.7)	2-3/4 (69.9)	9 (228.6)	1,005 (4.5)	1,165 (5.2)	420 (1.9)	490 (2.2)	-	-
	7-1/2 (190.5)	2-3/4 (69.9)	9 (228.6)	1,215 (5.4)	1,405 (6.2)	-	-	-	-

1. Tabulated load values are for carbon steel and stainless steel anchors installed in minimum 6-inch wide, minimum Grade N, Type II, lightweight, medium-weight or normal-weight concrete masonry units conforming to ASTM C 90. Mortar must be minimum Type N. Masonry compressive strength must be at the specified minimum at the time of installation.
2. Allowable load capacities listed are calculated using an applied safety factor of 5.0. Consideration of safety factors of 10 or higher may be necessary depending on the application, such as life safety or overhead.

**Allowable Load Capacities for Wedge-Bolt+ Anchors Installed into the T-Joint of Grout-Filled Concrete Masonry Wall<sup>1,2,3,4</sup>**

Nominal Anchor Diameter in. (mm)	Minimum Embed. Depth in. (mm)	Minimum Edge Distance in. (mm)	Minimum End Distance in. (mm)	Tension lbs. (kN)	Shear lbs. (kN)
3/8 (9.5)	1-1/2 (38.1)	16 (406.4)	16 (406.4)	-	510 (2.3)
	3-1/2 (88.9)			830 (3.7)	
1/2 (12.7)	4 (101.6)			1,090 (4.9)	
5/8 (15.9)	4 (101.6)			840 (3.8)	1,225 (5.5)
3/4 (19.1)	2-1/2 (63.5)			-	
	4 (101.6)			890 (4.0)	

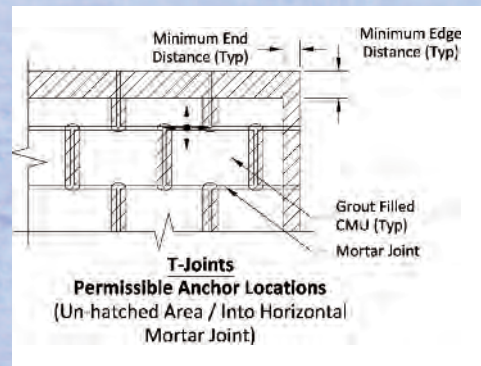

1. Tabulated load values are for carbon steel and stainless steel anchors installed in minimum 6-inch wide, minimum Grade N, Type II, lightweight, medium-weight or normal-weight concrete masonry units conforming to ASTM C 90. Mortar must be minimum Type N. Masonry compressive strength must be at the specified minimum at the time of installation (*f*'<sub>m</sub> ≥ 1,500 psi).
2. Allowable load capacities listed are calculated using an applied safety factor of 5.0. Consideration of safety factors of 10 or higher may be necessary depending on the application, such as life safety or overhead.
3. Allowable shear loads for anchor installation into the horizontal and vertical mortar joints may be applied in any direction provided the anchor location is a minimum of 16" from the edge and end of the wall. For anchor installations with an edge distance less than 16" the allowable shear loads may be applied in any direction except upward vertically.
4. Linear interpolation for allowable loads for anchors at intermediate embedment depths may be used.

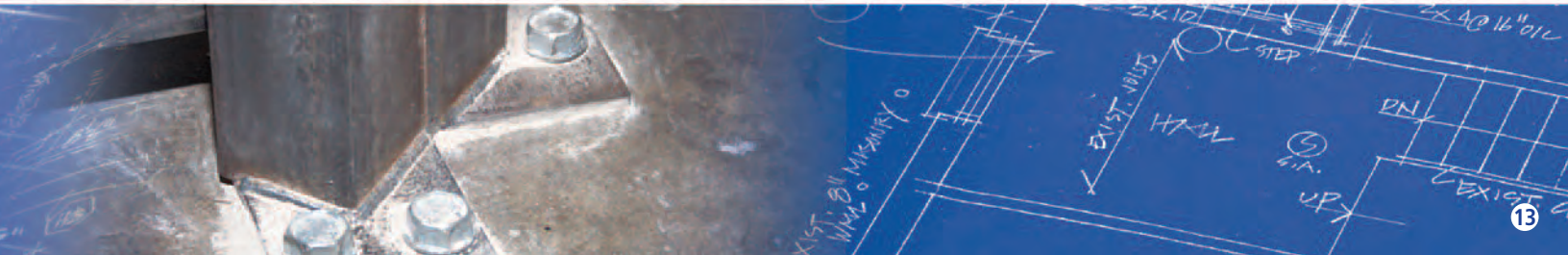



### MASONRY PERFORMANCE DATA

#### Allowable Load Capacities for Wedge-Bolt+ Anchors Installed into Multiple Wythe Solid Clay Brick Masonry<sup>1,2</sup>

Nominal Anchor Dia. d in. (mm)	Minimum Embed. Depth hv in. (mm)	Minimum Edge & End Distance in. (mm)	Minimum Spacing Distance in	Tension lbs. (kN)	Shear lbs. (kN)
1/4 (6.4)	2-1/2 (63.5)	4 (101.6)	4" Any Direction	455 (2.0)	295 (1.3)
3/8 (9.5)	3-1/2 (88.9)	6 (152.4)	6" Any Direction	680 (3.1)	630 (2.8)
1/2 (12.7)	4 (101.6)	8 (203.2)	8" Any Direction	960 (4.3)	1,230 (5.5)
5/8 (15.9)	4 (101.6)	10 (254.0)	12" Any Direction	1,225 (5.5)	1,710 (7.6)
3/4 (19.1)	4 (101.6)	12 (304.8)	16" Any Direction	1,315 (5.9)	1,950 (8.7)

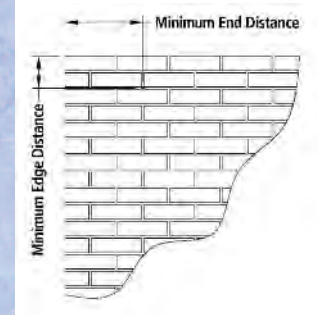

1. Tabulated load values are for anchors installed in multiple wythe, minimum Grade SW, solid clay brick masonry walls conforming to ASTM C 62. Mortar must be minimum Type N. Masonry compressive strength must be at the specified minimum at the time of installation ( $f'm \geq 1,500$  psi).
2. Allowable load capacities listed are calculated using an applied safety factor of 5.0. Consideration of safety factors of 10 or higher may be necessary depending on the application, such as life safety or overhead.

### DESIGN CRITERIA (ALLOWABLE STRESS DESIGN)

#### Combined Loading

For anchors loaded in both shear and tension, the combination of loads should be proportioned as follows:

$$\left(\frac{N_u}{N_n}\right)^{\frac{5}{3}} + \left(\frac{V_u}{V_n}\right)^{\frac{5}{3}} \leq 1 \quad \text{OR} \quad \left(\frac{N_u}{N_n}\right) + \left(\frac{V_u}{V_n}\right) \leq 1$$

Where:  $N_u$  = Applied Service Tension Load  
 $N_n$  = Allowable Tension Load  
 $V_u$  = Applied Service Shear Load  
 $V_n$  = Allowable Shear Load

#### Load Adjustment Factors for Spacing and Edge Distances<sup>1</sup>

Anchor Installed in Normal-Weight Concrete					
Anchor Dimension	Load Type	Critical Distance (Full Anchor Capacity)	Critical Load Factor	Minimum Distance (Reduced Capacity)	Minimum Load Factor
Spacing (s)	Tension	$s_{cr} = 12d$	$F_{NS} = 1.0$	$s_{min} = 4d$	$F_{NS} = 0.50$
	Shear	$s_{cr} = 12d$	$F_{VS} = 1.0$	$s_{min} = 4d$	$F_{VS} = 0.75$
Edge Distance (c)	Tension	$c_{cr} = 8d$	$F_{NC} = 1.0$	$c_{min} = 3d$	$F_{NC} = 0.70$
	Shear	$c_{cr} = 12d$	$F_{VC} = 1.0$	$c_{min} = 3d$	$F_{VC} = 0.15$

Anchor Installed in Structural Lightweight Concrete					
Anchor Dimension	Load Type	Critical Distance (Full Anchor Capacity)	Critical Load Factor	Minimum Distance (Reduced Capacity)	Minimum Load Factor
Spacing (s)	Tension	$s_{cr} = 14.1d$	$F_{NS} = 1.0$	$s_{min} = 4.7d$	$F_{NS} = 0.50$
	Shear	$s_{cr} = 14.1d$	$F_{VS} = 1.0$	$s_{min} = 4.7d$	$F_{VS} = 0.75$
Edge Distance (c)	Tension	$c_{cr} = 9.4d$	$F_{NC} = 1.0$	$c_{min} = 3.5d$	$F_{NC} = 0.70$
	Shear	$c_{cr} = 14.1d$	$F_{VC} = 1.0$	$c_{min} = 3.5d$	$F_{VC} = 0.15$

1. Allowable load values found in the performance data tables are multiplied by reduction factors when anchor spacing or edge distances are less than critical distances. Linear interpolation is allowed for intermediate anchor spacing and edge distances between critical and minimum distances. When an anchor is affected by both reduced spacing and edge distance, the spacing and edge reduction factors must be combined (multiplied). Multiple reduction factors for anchor spacing and edge distance may be required depending on the anchor group configuration.

## DESIGN CRITERIA (ALLOWABLE STRESS DESIGN)

### Load Adjustment Factors for Normal-Weight Concrete

Spacing, Tension ( $F_{Ns}$ )						
Dia. (in.)	1/4	3/8	1/2	5/8	3/4	
$S_{cr}$ (in.)	3	4 1/2	6	7 1/2	9	
$S_{min}$ (in.)	1	1 1/2	2	2 1/2	3	
Spacing, $s$ (inches)	1	0.50				
	1 1/2	0.63	0.50			
	2	0.75	0.58	0.50		
	2 1/2	0.88	0.67	0.56	0.50	
	3	1.00	0.75	0.63	0.55	0.50
	4 1/2		1.00	0.81	0.70	0.63
	6			1.00	0.85	0.75
	7 1/2				1.00	0.88
	9					1.00

Notes: For anchors loaded in tension, the critical spacing ( $S_{cr}$ ) is equal to 12 anchor diameters ( $12d$ ) at which the anchor achieves 100% of load.

Minimum spacing ( $S_{min}$ ) is equal to 4 anchor diameters ( $4d$ ) at which the anchor achieves 50% of load.

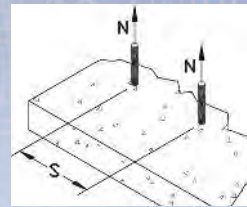

Spacing, Shear ( $F_{Vs}$ )						
Dia. (in.)	1/4	3/8	1/2	5/8	3/4	
$S_{cr}$ (in.)	3	4 1/2	6	7 1/2	9	
$S_{min}$ (in.)	1	1 1/2	2	2 1/2	3	
Spacing, $s$ (inches)	1	0.75				
	1 1/2	0.81	0.75			
	2	0.88	0.79	0.75		
	2 1/2	0.94	0.83	0.78	0.75	
	3	1.00	0.88	0.81	0.78	0.75
	4 1/2		1.00	0.91	0.85	0.81
	6			1.00	0.93	0.88
	7 1/2				1.00	0.94
	9					1.00

Notes: For anchors loaded in shear, the critical spacing ( $S_{cr}$ ) is equal to 12 anchor diameters ( $12d$ ) at which the anchor achieves 100% of load.

Minimum spacing ( $S_{min}$ ) is equal to 4 anchor diameters ( $4d$ ) at which the anchor achieves 75% of load.

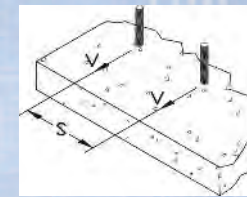

Edge Distance, Tension ( $F_{Nc}$ )						
Dia. (in.)	1/4	3/8	1/2	5/8	3/4	
$C_{cr}$ (in.)	2	3	4	5	6	
$C_{min}$ (in.)	3/4	1 1/8	1 1/2	1 7/8	2 1/4	
Edge Distance, $c$ (in.)	3/4	0.70				
	1 1/8	0.79	0.70			
	1 1/2	0.88	0.76	0.70		
	1 7/8	0.97	0.82	0.75	0.70	
	2	1.00	0.84	0.76	0.71	
	2 1/4		0.88	0.79	0.74	0.70
	3		1.00	0.88	0.81	0.76
	4			1.00	0.90	0.84
	5				1.00	0.92
	6					1.00

Notes: For anchors loaded in tension, the critical edge distance ( $C_{cr}$ ) is equal to 8 anchor diameters ( $8d$ ) at which the anchor achieves 100% of load.

Minimum edge distance ( $C_{min}$ ) is equal to 3 anchor diameters ( $3d$ ) at which the anchor achieves 70% of load.

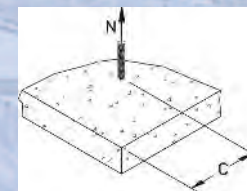

Edge Distance, Shear ( $F_{Vc}$ )						
Dia. (in.)	1/4	3/8	1/2	5/8	3/4	
$C_{cr}$ (in.)	3	4 1/2	6	7 1/2	9	
$C_{min}$ (in.)	3/4	1 1/8	1 1/2	1 7/8	2 1/4	
Edge Distance, $c$ (in.)	3/4	0.15				
	1 1/8	0.29	0.15			
	1 1/2	0.43	0.24	0.15		
	1 7/8	0.58	0.34	0.22	0.15	
	2 1/4	0.72	0.43	0.29	0.21	0.15
	3	1.00	0.62	0.43	0.32	0.24
	4 1/2		1.00	0.72	0.55	0.43
	6			1.00	0.77	0.62
	7 1/2				1.00	0.81
	9					1.00

Notes: For anchors loaded in shear, the critical edge distance ( $C_{cr}$ ) is equal to 12 anchor diameters ( $12d$ ) at which the anchor achieves 100% of load.

Minimum edge distance ( $C_{min}$ ) is equal to 3 anchor diameters ( $3d$ ) at which the anchor achieves 15% of load



# Wedge-Bolt®+

## DESIGN CRITERIA (ALLOWABLE STRESS DESIGN)

### Load Adjustment Factors for Structural Lightweight Concrete

Spacing, Tension ( $F_{NS}$ )						
Dia. (in.)	1/4	3/8	1/2	5/8	3/4	
$S_{cr}$ (in.)	3 1/2	5 1/4	7	8 7/8	10 1/2	
$S_{min}$ (in.)	1 1/4	1 3/4	2 3/8	3	3 1/2	
Spacing, $s$ (inches)	1 1/4	0.50				
	1 3/4	0.61	0.50			
	2 3/8	0.75	0.59	0.50		
	3	0.89	0.67	0.57	0.50	
	3 1/2	1.00	0.74	0.62	0.54	0.50
	5 1/4		1.00	0.82	0.70	0.63
	7			1.00	0.84	0.75
	8 7/8				1.00	0.88
	10 1/2					1.00

Notes: For anchors loaded in tension, the critical spacing ( $S_{cr}$ ) is equal to 14.1 anchor diameters ( $14.1d$ ) at which the anchor achieves 100% of load.

Minimum spacing ( $S_{min}$ ) is equal to 4.7 anchor diameters ( $4.7d$ ) at which the anchor achieves 50% of load.

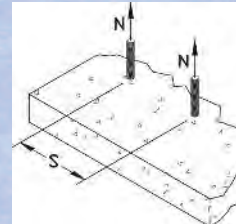

Spacing, Shear ( $F_{VS}$ )						
Dia. (in.)	1/4	3/8	1/2	5/8	3/4	
$S_{cr}$ (in.)	3 1/2	5 1/4	7	8 7/8	10 1/2	
$S_{min}$ (in.)	1 1/4	1 3/4	2 3/8	3	3 1/2	
Spacing, $s$ (inches)	1 1/4	0.75				
	1 3/4	0.81	0.75			
	2 3/8	0.88	0.79	0.75		
	3	0.94	0.84	0.78	0.75	
	3 1/2	1.00	0.87	0.81	0.77	0.75
	5 1/4		1.00	0.91	0.85	0.82
	7			1.00	0.92	0.88
	8 7/8				1.00	0.94
	10 1/2					1.00

Notes: For anchors loaded in shear, the critical spacing ( $S_{cr}$ ) is equal to 14.1 anchor diameters ( $14.1d$ ) at which the anchor achieves 100% of load.

Minimum spacing ( $S_{min}$ ) is equal to 4.7 anchor diameters ( $4.7d$ ) at which the anchor achieves 75% of load.

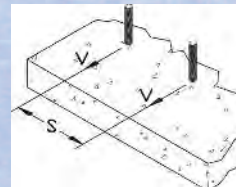

Edge Distance, Tension ( $F_{ND}$ )						
Dia. (in.)	1/4	3/8	1/2	5/8	3/4	
$C_{cr}$ (in.)	2 3/8	3 1/2	4 3/4	5 7/8	7	
$C_{min}$ (in.)	7/8	1 3/8	1 3/4	2 1/4	2 5/8	
Edge Distance, $c$ (in.)	7/8	0.70				
	1 3/8	0.80	0.70			
	1 3/4	0.88	0.76	0.70		
	2 1/4	0.98	0.83	0.75	0.70	
	2 3/8	1.00	0.84	0.76	0.72	
	2 5/8		0.88	0.79	0.74	0.70
	3 1/2		1.00	0.88	0.81	0.76
	4 3/4			1.00	0.91	0.84
	5 7/8				1.00	0.92
	7					1.00

Notes: For anchors loaded in tension, the critical edge distance ( $C_{cr}$ ) is equal to 9.4 anchor diameters ( $9.4d$ ) at which the anchor achieves 100% of load.

Minimum edge distance ( $C_{min}$ ) is equal to 3.5 anchor diameters ( $3.5d$ ) at which the anchor achieves 70% of load.

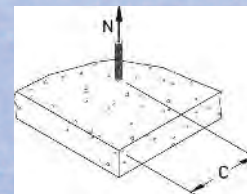

Edge Distance, Shear ( $F_{VD}$ )						
Dia. (in.)	1/4	3/8	1/2	5/8	3/4	
$C_{cr}$ (in.)	3 1/2	5 1/4	7	8 7/8	10 1/2	
$C_{min}$ (in.)	7/8	1 3/8	1 3/4	2 1/4	2 5/8	
Edge Distance, $c$ (in.)	7/8	0.15				
	1 3/8	0.31	0.15			
	1 3/4	0.43	0.24	0.15		
	2 1/4	0.59	0.35	0.23	0.15	
	2 5/8	1.00	0.43	0.29	0.21	
	3 1/2		0.62	0.43	0.32	0.15
	5 1/4		1.00	0.71	0.54	0.43
	7			1.00	0.77	0.62
	8 7/8				1.00	0.82
	10 1/2					1.00

Notes: For anchors loaded in shear, the critical edge distance ( $C_{cr}$ ) is equal to 14.1 anchor diameters ( $14.1d$ ) at which the anchor achieves 100% of load.

Minimum edge distance ( $C_{min}$ ) is equal to 3.5 anchor diameters ( $3.5d$ ) at which the anchor achieves 15% of load.



## ORDERING INFORMATION

### Wedge-Bolt+ Screw Anchor (Carbon Steel Body With Blue Tip)

Cat. No.	Anchor Size	Box Qty.	Ctn. Qty.	Wt./100 (lbs)
7204SD	1/4" x 1-1/4"	100	600	3
7206SD	1/4" x 1-3/4"	100	600	4
7208SD	1/4" x 2-1/4"	100	600	4
7210SD	1/4" x 3"	100	500	5
7220SD	3/8" x 1-3/4"	50	300	9
7222SD	3/8" x 2-1/2"	50	300	10
7224SD	3/8" x 3"	50	250	12
7226SD	3/8" x 4"	50	250	15
7228SD	3/8" x 5"	50	250	18
7230SD	3/8" x 6"	50	150	22
7240SD	1/2" x 2"	50	200	15
7242SD	1/2" x 2-1/2"	50	200	17
7244SD	1/2" x 3"	50	150	20
7246SD	1/2" x 4"	50	150	26
7248SD	1/2" x 5"	25	100	30
7250SD	1/2" x 6"	25	75	35
7268SD	1/2" x 6-1/2"	25	75	37
7252SD	1/2" x 8"	25	75	43
7260SD	5/8" x 3"	25	100	35
7262SD	5/8" x 4"	25	100	41
7264SD	5/8" x 5"	25	75	48
7266SD	5/8" x 6"	25	75	54
7270SD	5/8" x 8"	25	75	65
7280SD	3/4" x 3"	20	60	50
7282SD	3/4" x 4"	20	60	60
7284SD	3/4" x 5"	20	60	71
7286SD	3/4" x 6"	20	60	81
7288SD	3/4" x 8"	10	40	103
7290SD	3/4" x 10"	10	30	100

☐ These sizes not SD Compliant.

### Wedge-Bolt+ Screw Anchor (Mechanically Galvanized)

Cat. No.	Anchor Size	Box Qty.	Ctn. Qty.
7726SD	3/8" x 4"	50	250
7728SD	3/8" x 5"	50	250
7730SD	3/8" x 6"	50	150
7246SD	1/2" x 4"	50	150
7248SD	1/2" x 5"	25	100
7250SD	1/2" x 6"	25	75
7751SD	1/2" x 6-1/2"	25	75
7252SD	1/2" x 8"	25	75
7764SD	5/8" x 5"	25	75
7766SD	5/8" x 6"	25	75
7768SD	5/8" x 6-1/2"	25	75
7770SD	5/8" x 8"	25	75
7786SD	3/4" x 6"	20	60
7789SD	3/4" x 8-1/2"	10	40
7790SD	3/4" x 10"	10	20

### Wedge-Bolt+ Screw Anchor Installation Accessories

Cat. No.	Description	Wt./100 (lbs)
08280	Hand pump / dust blower	1

The published size includes the diameter and length of the anchor measured from under the head.

Wedge-Bolt is marked with a blue tip and must be installed with a matched tolerance Wedge-bit.

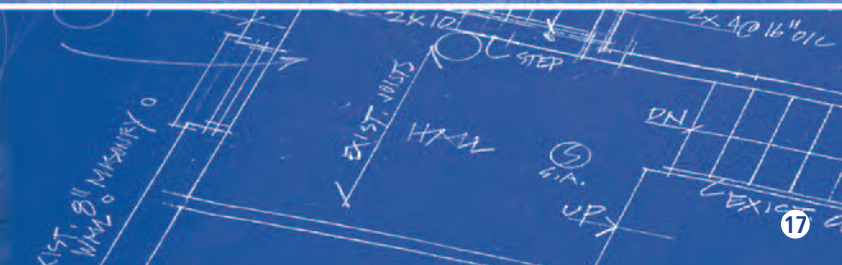
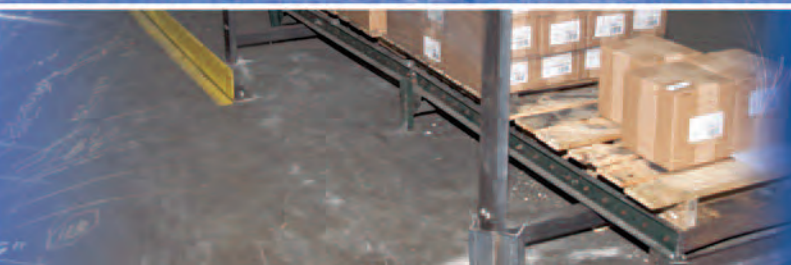

# Wedge-Bit

SDS

Spline

SDS-  
Max

HD  
Straight  
Shank



## ORDERING INFORMATION

### Wedge-Bit

Cat. No.	Wedge-Bit Description	Usable Length	Tube Qty.	Ctn. Qty.
01312	SDS 1/4" x 4"	2"	1	250
01314	SDS 1/4" x 6"	4"	1	100
01316	SDS 3/8" x 6"	4"	1	200
01318	SDS 3/8" x 8"	6"	1	100
01332	SDS 3/8" x 12"	10"	1	50
01319	SDS 3/8" x 18"	16"	1	50
01320	SDS 1/2" x 6"	4"	1	150
01322	SDS 1/2" x 10"	8"	1	50
01334	SDS 1/2" x 12"	10"	1	50
01335	SDS 1/2" x 18"	16"	1	50
01324	SDS 5/8" x 8"	6"	1	75
01326	SDS 5/8" x 12"	10"	1	75
01336	SDS 5/8" x 18"	16"	1	50
01328	SDS 3/4" x 8"	6"	1	100
01330	SDS 3/4" x 12"	10"	1	50
01340	Spline 1/2" x 13"	8"	1	20
01342	Spline 1/2" x 16"	11"	1	-
01344	Spline 5/8" x 13"	8"	1	20
01348	Spline 3/4" x 13"	8"	1	20
01354	SDS-Max 1/2" x 13"	8"	1	20
01356	SDS-Max 5/8" x 13"	8"	1	20
01358	SDS-Max 3/4" x 13"	8"	1	20
01370	HD Straight Shank 1/4" x 4"	3"	1	100
01372	HD Straight Shank 1/4" x 6"	2-1/2"	1	-
01380	HD Straight Shank 3/8" x 6"	4"	1	-
01384	HD Straight Shank 3/8" x 13"	4"	1	-
01390	HD Straight Shank 1/2" x 6"	11"	1	-
01394	HD Straight Shank 1/2" x 13" HD	11"	1	50
01396	Straight Shank 5/8" x 13"	11"	1	-
01397	HD Straight Shank 3/4" x 13"	11"	1	-

SPECIFICATION "BEST PRACTICE"

# Ensure That Your Project Documents Match Your Design



SCAN THIS QR CODE TO LINK TO A DIGITAL SPECIFICATION FOR ANCHORS WRITTEN AND PROVIDED BY POWERS FASTENERS WITH GOVERNING STANDARDS REFERENCED.

Today in virtually every jurisdiction in the U.S. the "Code Basis for Building Construction" is in some edition of the International Building Code (IBC). By default, the General Notes, Structural and MEP Specifications require compliance to the IBC. For the purpose of post-installed concrete anchor design, the IBC requires that the "Strength Design" method be used.

The reality is far too often these specifications are obsolete with respect to anchors in concrete. When that happens, the project documents are in conflict with one another and in conflict with the IBC.

## CSI Section for Mechanical & Adhesive Anchors – 03 16 00 and 05 05 19

Don't put your project at risk. Powers understands the importance of code approved anchoring options. That's why we've dedicated ourselves to engineering a range of products that meet the new building code, and to developing ways to support those products.

# PDA Powers Design Assist®

## Real-Time Anchor Design Software V2.0

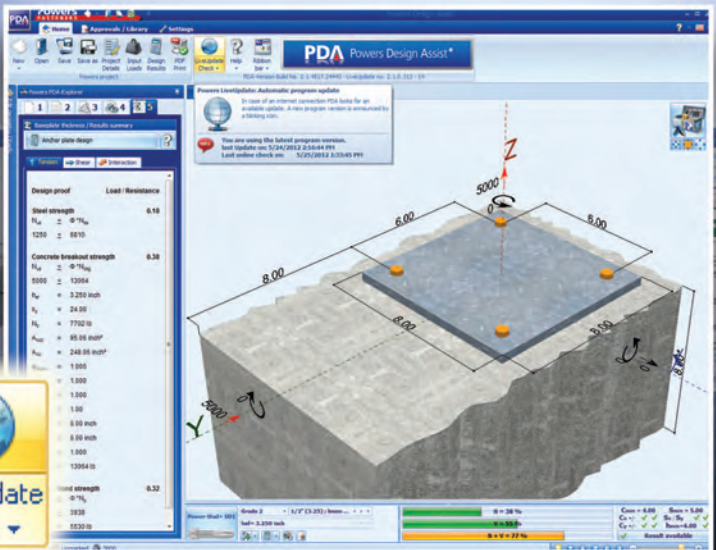
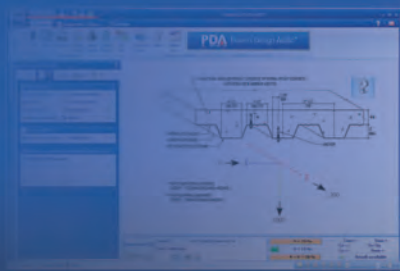

**PDA'S LIVE UPDATE FEATURE ENSURES THAT SOFTWARE IS ALWAYS LOADED WITH UP-TO-DATE PRODUCTS, FEATURES AND CODE REFERENCES.**



For a full listing of code approved products, and a demo on the latest version of PDA go to [www.powers.com](http://www.powers.com) or call (800) 524-3244 for a free demo.

**Powers**  
FASTENING INNOVATIONS

Powers Fasteners, Inc.  
2 Powers Lane  
Brewster, NY 10509  
www.powers.com  
P: (914) 235-6300  
F: (914) 576-6483

## POWERS FASTENERS BRANCH INFORMATION

## USA LOCATIONS

CITY	ADDRESS	CONTACT	PHONE	FAX
Alabama	5405 Buford Hwy Suite 410 Norcross, GA 30071-3984	Jeff Hatchett	678-966-0000	678-966-9242
Atlanta	5405 Buford Hwy Suite 410 Norcross, GA 30071-3984	Ryan Raica	678-966-0000	678-966-9242
Boston	2 Powers Lane, Brewster, NY 10509	Jack Armour	800-524-3244	877-871-1965
Charlotte	349 L West Tremont Avenue, Charlotte, NC 28203	Bob Aurisy	704-375-5012	704-376-5517
Chicago	2472 Wisconsin Avenue, Downers Grove, IL 60515	Dan Gilligan	630-960-3156	630-960-3912
Dallas	1300 IH 35 North, Suite #118, Carrollton TX 75006	Matt Henderson	972-506-9258	972-506-9290
Denver	2475 West Second Street #35, Denver, CO 80223	Jared Hemmert	303-922-9202	303-922-9228
Detroit	21600 Wyoming Avenue, Oak Park, MI 48237	Glen Gaskill	248-543-8600	248-543-8601
Florida	2412 Lynx Lane, Orlando, FL 32804	John Christy	813-626-4500	813-626-4545
Houston	13833 North Promenade, Suite 100, Stafford, TX 77477	Vaughn Eshelman	281-491-0351	281-491-0367
Indianapolis	15290 Stony Creek Way, Noblesville, IN 46060	Ian Jones	317-773-1668	317-773-1690
Los Angeles	2761 Dow Avenue, Tustin, CA 92780	John Kenny	714-731-2500	714-731-2566
Maryland	3137-B Pennsy Drive, Landover, MD 20785	Chris Van Syckle	301-773-1722	301-341-5119
Milwaukee	12020 W. Feerick Street, Milwaukee, WI 53222	Donn Raduenz	414-466-2400	414-466-3993
Minneapolis	351 Wilson Street, NE Minneapolis, MN 55413	Josh Nelson	612-331-3770	612-331-3549
Missouri	3225 Harvester Road, Kansas City, KS 66115	Don James, Jr.	816-472-5033	816-472-5040
New Orleans	102 Sampson Street, Houston, TX 77003	Gary Button	713-228-1524	713-228-1528
New York	2 Powers Lane, Brewster, NY 10509	Matt Reap	800-524-3244	877-871-1965
Philadelphia	2 Powers Lane, Brewster, NY 10509	Greg Stephenson	800-524-3244	877-871-1965
Phoenix	3602 E. Southern Ave, Suite 5 Phoenix, AZ 85040	Patrick Stysly	602-431-8024	602-431-8027
Pittsburgh	1360 Island Avenue, McKees Rocks, PA 15136	Bill Dugan	412-771-3010	412-771-9858
Portland	18808 142nd Ave NE, Suite 4A, Woodinville, WA 98072	Jim Swink	360-608-6845	206-762-5817
Rochester	36 Van Auken Blvd., Rochester, NY 14608	Mark Harper	800-524-3244 / 585-529-4188	877-871-1965 / 585-529-5319
Salt Lake City	3120 W. California Ave, Suite E, Salt Lake City, UT 84104	Don Manning	801-466-9428	801-466-3083
San Francisco	28970 Hopkins Street, Suite B+C, Hayward, CA 94545	John O'Brien/Craig Hering	510-293-1500	510-293-1505
Seattle	18808 142nd Ave NE, Suite 4A, Woodinville, WA 98072	Darin Arnold	206-762-5812	206-762-5817
Tennessee	221 Blanton Avenue, Nashville, TN 37210	Jamie Utley/John Hazen Sr.	615-248-2667	615-248-2676

## INTERNATIONAL LOCATIONS

COUNTRY/REGION	ADDRESS	CONTACT	PHONE	FAX
Australia	Factory 3, 205 Abbotts Road, Dandenong, South Victoria 3175	Peter Pratis	+61 3 8787 5888	+61 3 8787 5899
Canada	6275 Millcreek Drive, Mississauga, Ontario L5N 7K6	Joe Diilio	1-800-567-7188	1-800-265-9680
China	Metropolitan Business Centre, East Nandan Road, Lane 300, No. 9, Room 604 Xuhui District, Shanghai, China 200030	Tina Ge	+86-21-3363-2880	+86-21-5080-5389
Europe	Westrak 208, 1771 SV Wieringerwerf, Netherlands	Colin Earl	+31 888 769 377	+31 227 594 759
Manitoba	1810 Dublin Avenue Man. Winnipeg, R3H 0H3	Distributor	204-633-0064	204-694-1261
New Zealand	PO Box 302 076 North Harbour Auckland	Clay Sesto	+64 9415 2425	+64 9415 2627
Quebec	721 Meloche Avenue, Dorval, Quebec H9P 2S5	Allan Hill	514-631-4216	514-631-2583

## LATIN &amp; CARIBBEAN DISTRIBUTION INQUIRIES

COUNTRY/REGION	ADDRESS	CONTACT	PHONE	FAX
Latin America		Allan Herbert	01150767477749	877-871-1965

## LATIN &amp; CARIBBEAN DISTRIBUTION

COUNTRY/REGION	ADDRESS	CONTACT	PHONE	FAX
Brazil	HARD, Rua Dr. Humberto Pinheiro Viera, 150 Lote B, 1 B Distrito Industrial, Joinville, Brazil		55-47-40097209	55-47-40097217
Colombia	Electrogeno, S.A., Carrera 52 #71c-38, Bogota, Colombia		(57) 1 6600 9436	
Costa Rica	Electro Mechanics Supply, La Uruca Contiguo Banco Ntnl., De Costa Rica Condominio, Horizontal Bodega #9, San Jose, Costa Rica		(506) 2233-2595	
Dominican Republic	Calle Estancia Nueva #17 E Esquina Cul-De-Sac 9, San Gerónimo, Santo Domingo	Rodfor Team	809-224-5615	809-472-8640
Ecuador	Acero Comercial Ecuatoriano S.A., Av. La Prensa N45-14 y Telégrafo 1 – Quito Av. Juan Tanca Marengo Km. 1.7 – Guayaquil	info@acero.comercial.com info@acero.comercial.com	(593-2) 2454 333 (593-4) 2683 060	(593-2) 2454 455 (593-4) 2683 059
Guatemala	Tecnofijaciones, 6 Avenue 8-56 Zona 9, Zona 9, Guatemala	Oscar Lucas Penagos	502-233-4-3478	
Panama	Centro-Industrial, Via Cincuentenario, No. 7910, Ciudad Panama, Panama		(507) 302-8022	
Peru	Powers Peruana SAC, Av. Santa Catalina, 555 La Victoria, Lima 13, Peru (www.powersperuana.com)	Martin Vasquez	(011) 511 265 8500	(011) 511 330 0909
Venezuela	Calle Sucre/Qta. Maudora, #1721 Entre Cec Acosta Y San Ignacio Chacao, Caracas	Distributor	58 212 264 1313	58 212 263 0219
Trinidad - Tobago	Ft. Farfan, 3-5 Ibis Avenue, Ibis Acres, San Juan	Derek Cumming	(868) 674-7896	

Note: The information and data contained within this documentation was current as of September 2013. The information is for marketing purposes only and is subject to change and updates as needed. Powers Fasteners, Inc. reserves the right to change designs and specifications without notice or liability for such changes. Please contact Powers Fasteners for the most current and up to date available information or refer to our website at [www.powers.com](http://www.powers.com)

Powers Fasteners 2 Powers Lane, Brewster, NY 10509 P: (800) 524-3244 F:(877) 871-1965



[www.powers.com](http://www.powers.com)

Cat. No. 49083 9/13

©2013 Powers Fasteners, Inc.