

WOOD

STEEL

VERTIGO®+

CODE LISTED  
ICC-ES ESR-2989

CONCRETE

**Powers**

FASTENING INNOVATIONS

# Vertigo

Rod Hanging System



# Vertigo<sup>®</sup>



## PRODUCT DESCRIPTION

Vertigo™ an all steel threaded fastening system for suspending steel threaded rod vertically overhead in pipe hanging, fire protection, electrical conduit and cable-tray applications. Vertigo are available in three versions which can be installed in a variety of base materials including steel purlins, bar joists and beams, wood frame columns and beams, as well as concrete ceilings, beams and columns.

Steel threaded rods in 1/4", 3/8" and 1/2" diameters can be vertically suspended with Vertigo. In wood and steel base materials, Vertigo is also offered in a side mount style for lateral installation of 1/4" and 3/8" diameter steel threaded rods onto joists, columns and overhead members. For all steel and wood Vertigo fasteners, a universal Vertigo Socket Driver is recommended to provide proper installation with a screw gun or hammer drill. Concrete Vertigo fasteners should be installed with the appropriate size standard drive sockets and adjustable torque, battery powered screw gun or hammer drill.

## TESTING AND EVALUATION

- Hanging Pipe and Sprinkler Systems
- Lighting Systems and Overhead Utilities
- Suspended Ceilings
- Suspending Conduit and Cable Trays
- HVAC Ductwork and Strut Channels
- Mounting Security Equipment

## FEATURES AND BENEFITS

- One system for all rod hanging applications in steel, wood and concrete
- Ease and speed of overhead installation
- Lower in-place cost, when compared to beam clamps, lag bolts and dropins
- Steel and wood Vertigo can be installed with a screw gun or hammer drill
- Concrete Vertigo can be installed with an adjustable torque, battery powered screw gun or hammer drill
- Side mount versions available for steel and wood Vertigo
- The universal socket can be used for the steel and wood Vertigo

## APPROVALS AND LISTINGS

Factory Mutual Research Corporation (FM Approvals) File No. J.I 3015153  
Underwriters Laboratory (UL) File No. EX 1289 (N)

## GUIDE SPECIFICATIONS

**CSI Divisions:** 03151-Concrete Anchoring, 05090-Metal Fastenings.  
06060-Wood Connections and Fasteners. Rod Hangers shall be Vertigo anchors as supplied by Powers Fasteners, Inc., Brewster, NY.

## MATERIAL SPECIFICATIONS

### Steel and Wood Vertigo

Component	Component Material
Screw Body	AISI 1018-1022 (Case Hardened)
Coupling	AISI 1018-1022 (Case Hardened)
Zinc Plating	ASTM B633, SC1, Type III (Fe/Zn5)

### Concrete Vertigo (Wedge-Bolt OT)

Component	Component Material
Anchor Body	Case Hardened 10B21 Carbon Steel
Zinc Plating	ASTM B633, SC1, Type III (Fe/Zn5)

## ANCHOR MATERIALS

Zinc Plated Carbon Steel

## ROD/ANCHOR SIZE RANGE (TYP.)

1/4" to 1/2" for Steel  
1/4" to 1/2" for Wood  
1/4" to 1/2" for Concrete

## SUITABLE BASE MATERIALS

Steel Purlins and Beams  
Wood and Timber  
Normal-weight concrete  
Structural Lightweight concrete  
Hollow Core Concrete Plank

## INSTALLATION SPECIFICATIONS

### Steel Vertigo

Point Style	#3	#5
Self Drilling Range	0.036" (20 gage) - 0.188" (3/16")	0.188" (3/16") - 0.500" (1/2")
Screw Size (UNC)	1/3-20 thread	1/4-20 thread
Root Diameter (in.)	13/64	13/64
Thread Length (in.)	1-3/16" (1-1/2" screw)	1-3/16" (1-1/2" screw)
Flange Thickness (in.)	1/16	1/16
Drill Speed (RPM)	500-1,500	500-1,500

Install with universal steel and wood socket.

### Wood Vertigo

Screw Size	1/4" Thread Forming	5/16" Thread Forming
Pre-drill Diameter (in.) (if required)	1/8	1/8
Point Style	Type 17	Type 17
Root Diameter (in.)	3/16	7/32
Thread Length (in.)	Screw length less 5/16	Screw length less 5/16
Flange Thickness (in.)	1/16	1/16

Install with universal steel and wood socket.

### Vertigo Couplings (Steel & Wood)

Coupling Size and Type	1/4" Vertical	3/8" Vertical	1/2" Vertical	1/4" Side	3/8" Side
Thread Size (UNC)	1/4-20	3/8-16	1/2-13	1/4-20	3/8-16
Thread Depth (in.)	3/8	3/8	3/8	5/8 (through)	5/8 (through)
Width (flat to flat) (in.)	5/8	5/8	5/8	5/8	5/8
Height (in.)	13/16	13/16	13/16	13/16	13/16

### Concrete Vertigo (Wedge-Bolt OT)

Rod Diameter/Anchor Size	1/4"	3/8"	1/2"
ANSI Drill Bit (in.)	1/4	1/4	3/8
Overall Screw Shank Length	1-1/4	1-1/2	2-3/4
Anchor Thread Length (in.)	1-1/8	1-3/8	2-1/2
Root Diameter (in.)	16/64	15/64	23/64
Coupling / Washer Height (in.)	27/64	9/16	53/64
Integral Washer O.D. (in.)	31/64	39/64	31/32
Coupling Thread Size (UNC)	1/3-20	3/8-16	1/2-13
Coupling Thread Depth (in.)	3/8	1/2	3/4
Socket Driver Size (in.)	3/8	1/2	11/16

Install with appropriate sized concrete socket.

## INSTALLATION GUIDELINES

### Wear eye protection.

If pre-drilling is required (certain types of wood truss/wood joist and all concrete base materials), select the recommended drill bit type and diameter. For Concrete Vertigo only, drill to the appropriate embedment depth, adding at least one diameter (1/4" to 1/2") to the drilling depth to prevent the tip of the fastener from running into a dead end at the rear of the anchor hole.

#### Concrete

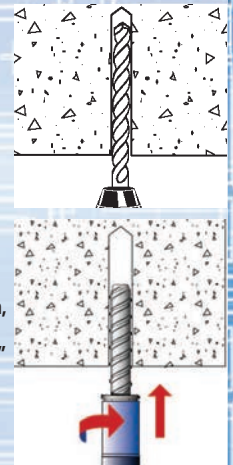

Select the appropriate socket driver for the anchor size and type to be installed and mount into chuck of installation tool. Insert the Vertigo fastener into the socket driver, and install perpendicular to the base material surface. Drive the fastener with a smooth steady motion until the coupling is firmly seated against the surface of the base material.

#### Steel

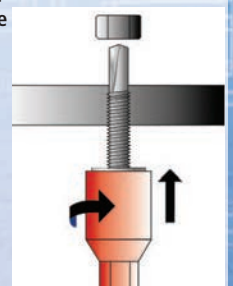

Thread the appropriate diameter steel threaded rod or threaded bolt into the coupling. The threaded rod or bolt should fully engage the thread length of the coupling on a vertical mount fastener. The threaded rod or threaded portion of the bolt can pass through coupling of a side mount fastener.

#### Wood

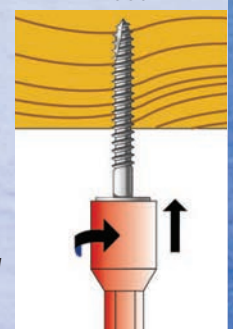

For UL and FM listings, Steel Vertigo should be installed with a retaining nut.

## PERFORMANCE DATA

### Steel Vertigo – Ultimate Tension Load Capacities when Installed in Minimum ASTM A 36 Steel (Beams) and ASTM A 572 Steel (Purlins)<sup>1,2</sup>

Anchor Size / Rod Diameter in. (mm)	Mount Direction	Screw Shank Size and Length	Minimum Steel Gage (Thickness)						
			20 0.036" lbs. (kN)	18 0.048" lbs. (kN)	16 0.060" lbs. (kN)	14 0.075" lbs. (kN)	12 0.105" lbs. (kN)	3/16" 0.187" lbs. (kN)	1/4" 0.250" lbs. (kN)
1/4 (6.4)	Vertical	1/4-20 x 1" (w/nut)	1,550 (7.0)	1,550 (7.0)	1,775 (8.0)	1,775 (8.0)	2,050 (9.2)	3,850 (17.3)	-
	Vertical	1/4-20 x 1"	405 (1.8)	620 (2.8)	985 (4.4)	1,160 (5.2)	1,560 (7.0)	3,205 (14.4)	5,040 (22.7)
	Side	1/4-20 x 1" (w/nut)	1,550 (7.0)	1,550 (7.0)	1,775 (8.0)	1,775 (8.0)	2,050 (9.2)	3,850 (17.3)	-
3/8 (9.5)	Vertical	1/4-20 x 1" (w/nut)	1,550 (7.0)	1,550 (7.0)	1,775 (8.0)	1,775 (8.0)	2,050 (9.2)	3,850 (17.3)	-
	Side	1/4-20 x 1-1/2" (w/nut)	1,550 (7.0)	1,550 (7.0)	1,775 (8.0)	1,775 (8.0)	2,050 (9.2)	3,850 (17.3)	-
	Vertical	1/4-20 x 1-1/2"	405 (1.8)	620 (2.8)	985 (4.4)	1,160 (5.2)	1,560 (7.0)	3,205 (14.4)	-
	Side	1/4-20 x 1-1/2"	405 (1.8)	620 (2.8)	985 (4.4)	1,160 (5.2)	1,560 (7.0)	1,965 (8.8)	-
	Vertical	1/4-20 x 2" (w/nut)	1,550 (7.0)	1,550 (7.0)	1,775 (8.0)	1,775 (8.0)	2,050 (9.2)	3,850 (17.3)	-
1/2 (12.7)	Vertical	12-20 x 1-1/2"	495 (2.20)	710 (3.2)	920 (4.1)	1,560 (7.0)	2,050 (9.2)	3,280 (14.8)	5,040 (22.7)
	Vertical	12-20 x 1-1/2" (w/nut)	1,550 (7.0)	1,550 (7.0)	1,775 (8.0)	1,775 (8.0)	2,050 (9.2)	3,850 (17.3)	-

1. For Steel Vertigo loaded perpendicular to threaded rod (shear) the ultimate load capacity for the anchor is 1,965 lbs in nominal 20 gage steel (0.036")

### Wood Vertigo – Ultimate Tension Load Capacities when Installed in Wood Base Materials (Structural Wood and Timber)<sup>1,2</sup>

Anchor Size / Rod Diameter in. (mm)	Mount Direction	Screw Shank Size and Length	Embedment Depth in. (mm)	Wood Member (Type)		
				Fir lbs. (kN)	Pine lbs. (kN)	Spruce lbs. (kN)
1/4 (6.4)	Vertical	1/4 x 1"	1 (25.4)	685 (3.1)	650 (2.9)	650 (2.9)
	Side	1/4 x 2"	2 (50.8)	1,510 (6.8)	1,510 (6.8)	1,510 (6.8)
3/8 (9.5)	Vertical	1/4 x 1"	1 (25.4)	685 (3.1)	650 (2.9)	650 (2.9)
	Side	1/4 x 1"	1 (25.4)	685 (3.1)	650 (2.9)	650 (2.9)
	Vertical	1/4 x 2"	2 (50.8)	1,510 (6.8)	1,510 (6.8)	1,510 (6.8)
	Side	1/4 x 2"	2 (50.8)	1,800 (8.1)	1,800 (8.1)	1,800 (8.1)
	Vertical	1/4 x 3"	3 (76.2)	2,075 (9.3)	1,510 (6.8)	1,510 (6.8)
	Vertical	1/4 x 4"	4 (101.6)	2,075 (9.3)	1,510 (6.8)	1,510 (6.8)
	Vertical	5/16" x 2-1/2"	2-1/2 (63.5)	2,670 (12.0)	3,110 (14.0)	3,110 (14.0)
	Side	3/8" x 2-1/2"	2-1/2 (63.5)	1,450 (6.5)	1,530 (6.9)	1,380 (6.2)
1/2 (12.7)	Vertical	5/16" x 2-1/2"	2-1/2 (63.5)	2,670 (12.0)	3,110 (14.0)	3,110 (14.0)

1. Truss/joist manufacturers may require pre-drilled holes with wood depending on the location of the anchor installation. Consult with the truss/joist manufacturer for details.  
2. Wood Vertigo are recommended to be installed with the Universal Steel & Wood Nut Driver.

## PERFORMANCE DATA

### Concrete Vertigo – Ultimate Load Capacities when Installed in Normal-Weight Concrete<sup>1,2</sup>

Anchor Size / Rod Diameter in. (mm)	Mount Direction	Screw Shank Size and Length	ANSI Drill Bit Diameter d <sub>bit</sub> in.	Embed. Depth h <sub>v</sub> in. (mm)	Minimum Concrete Compressive Strength (f'c)					
					2,000 psi (13.8 MPa)		4,000 psi (20.7 MPa)		6,000 psi (41.4 MPa)	
					Tension lbs. (kN)	Shear lbs. (kN)	Tension lbs. (kN)	Shear lbs. (kN)	Tension lbs. (kN)	Shear lbs. (kN)
1/4 (6.4)	Vertical	1/4" x 1 1/4"	1/4"	1-1/4 (31.8)	1,390 (6.3)	1,810 (8.1)	1,950 (8.8)	2,440 (11.0)	2,070 (9.3)	2,570 (11.6)
3/8 (9.5)	Vertical	1/4" x 1 1/2"	1/4"	1-1/2 (38.1)	1,760 (7.9)	2,580 (11.6)	2,595 (11.7)	2,640 (11.9)	2,770 (12.5)	2,700 (12.2)
1/2 (12.7)	Vertical	3/8" x 2 3/4"	3/8"	2-3/4 (69.9)	5,320 (23.9)	5,250 (23.6)	6,050 (27.2)	6,330 (28.5)	8,620 (38.8)	7,410 (33.0)

1. The values listed above are ultimate load capacities which should be reduced by a minimum safety factor of 4.0 or greater to determine the allowable working load.
2. Linear interpolation may be used to determine ultimate loads for intermediate compressive strengths.

### Concrete Vertigo – Ultimate Load Capacities when Installed Through Metal Deck into Structural Lightweight Concrete<sup>1,2,3,4,5</sup>

Anchor Size / Rod Diameter d in. (mm)	Embedment Depth h <sub>v</sub> in. (mm)	Lightweight Concrete Over Minimum 20 Ga. Metal Deck f'c ≥ 3,000 psi (20.7 MPa)	
		Minimum 4 1/2" Wide Deck	
		Tension lbs. (kN)	Load at 45° lbs. (kN)
1/4 (6.4)	1-1/4 (31.8)	800 (3.6)	1,140 (5.1)
3/8 (9.5)	1-1/2 (38.1)	1,780 (8.0)	1,500 (6.8)
1/2 (12.7)	2-3/4 (69.9)	3,880 (17.5)	2,920 (13.1)

1. The values listed above are ultimate and allowable load capacities for Vertigo rod hangers installed in sand-lightweight concrete.
2. The metal deck shall be minimum No. 20 gage thick steel (0.035-inch base metal thickness (0.89 mm)) conforming to ASTM A 653/ A 653M.
3. Allowable loads capacities are calculated using an applied safety factor of 4.0.
4. The tabulated load values are for anchors installed with a minimum flute edge distance of 1 1/2-inch.
5. Allowable loads for anchors to resist short-term loads such as earthquake or wind may be increased by 33-1/3 percent for the duration of the load where permitted by code.

### Concrete Vertigo – Ultimate Tension Load Capacities when Installed in Hollow Core Concrete Plank<sup>1,2</sup>

Anchor Size / Rod Diameter in. (mm)	Mount Direction	Screw Shank Size and Length	ANSI Drill Bit Diameter d <sub>bit</sub> in.	Embedment Depth h <sub>v</sub> in. (mm)	Center of Web lbs. (kN)	Center of Core lbs. (kN)
1/4 (6.4)	Vertical	1/4" x 1-1/4"	1/4"	1-1/4 (31.8)	2,775 (12.3)	1,920 (8.5)
3/8 (9.5)	Vertical	1/4" x 1-1/2"	1/4"	1-1/2 (38.1)	3,700 (16.5)	2,570 (11.4)
1/2 (12.7)	Vertical	3/8" x 2-3/4"	3/8"	2-3/4 (69.9)	8,240 (36.7)	3,480 (15.5)

1. Tabulated load values are for anchors installed in 8-inch-thick hollow core plank with minimum compressive strength of 5,000 psi at the time of installation. The 4' x 6' normal-weight concrete members features include 1-1/2" cover above and below cores and a minimum web thickness of 1-1/2".
2. Depending on fastener application and governing building code, ultimate load capacities should be reduced by a minimum safety factor to determine the allowable working load. NFPA 13 Fire Protection requirements are 5 times the weight of the liquid (water) filled pipe plus 250 lbs. Consult the engineer of record.

## PERFORMANCE DATA

### Concrete Vertigo – Ultimate Load Capacities when Installed in Normal-Weight Concrete<sup>1,2</sup>

Anchor Size / Rod Diameter in. (mm)	Mount Direction	Screw Shank Size and Length	ANSI Drill Bit Diameter d <sub>bit</sub> in.	Embed. Depth h <sub>v</sub> in. (mm)	Minimum Concrete Compressive Strength (f' <sub>c</sub> )					
					2,000 psi (13.8 MPa)		4,000 psi (20.7 MPa)		6,000 psi (41.4 MPa)	
					Tension lbs. (kN)	Shear lbs. (kN)	Tension lbs. (kN)	Shear lbs. (kN)	Tension lbs. (kN)	Shear lbs. (kN)
1/4 (6.4)	Vertical	1/4" x 1 1/4"	1/4"	1-1/4 (31.8)	1,390 (6.3)	1,810 (8.1)	1,950 (8.8)	2,440 (11.0)	2,070 (9.3)	2,570 (11.6)
3/8 (9.5)	Vertical	1/4" x 1 1/2"	1/4"	1-1/2 (38.1)	1,760 (7.9)	2,580 (11.6)	2,595 (11.7)	2,640 (11.9)	2,770 (12.5)	2,700 (12.2)
1/2 (12.7)	Vertical	3/8" x 2 3/4"	3/8"	2-3/4 (69.9)	5,320 (23.9)	5,250 (23.6)	6,050 (27.2)	6,330 (28.5)	8,620 (38.8)	7,410 (33.0)

1. The values listed above are ultimate load capacities which should be reduced by a minimum safety factor of 4.0 or greater to determine the allowable working load.
2. Linear interpolation may be used to determine ultimate loads for intermediate compressive strengths.

### Concrete Vertigo – Ultimate Load Capacities when Installed Through Metal Deck into Structural Lightweight Concrete<sup>1,2,3,4,5</sup>

Anchor Size / Rod Diameter d in. (mm)	Embedment Depth h <sub>v</sub> in. (mm)	Lightweight Concrete Over Minimum 20 Ga. Metal Deck f' <sub>c</sub> ≥ 3,000 psi (20.7 MPa)	
		Minimum 4 1/2" Wide Deck	
		Tension lbs. (kN)	Load at 45° lbs. (kN)
1/4 (6.4)	1-1/4 (31.8)	800 (3.6)	1,140 (5.1)
3/8 (9.5)	1-1/2 (38.1)	1,780 (8.0)	1,500 (6.8)
1/2 (12.7)	2-3/4 (69.9)	3,880 (17.5)	2,920 (13.1)

1. The values listed above are ultimate and allowable load capacities for Vertigo rod hangers installed in sand-lightweight concrete.
2. The metal deck shall be minimum No. 20 gage thick steel [0.035-inch base metal thickness (0.89 mm)] conforming to ASTM A 653/ A 653M.
3. Allowable loads capacities are calculated using an applied safety factor of 4.0.
4. The tabulated load values are for anchors installed with a minimum flute edge distance of 1 1/2-inch.
5. Allowable loads for anchors to resist short-term loads such as earthquake or wind may be increased by 33-1/3 percent for the duration of the load where permitted by code.

### Concrete Vertigo – Ultimate Tension Load Capacities when Installed in Hollow Core Concrete Plank<sup>1,2</sup>

Anchor Size / Rod Diameter in. (mm)	Mount Direction	Screw Shank Size and Length	ANSI Drill Bit Diameter d <sub>bit</sub> in.	Embedment Depth h <sub>v</sub> in. (mm)	Center of Web lbs. (kN)	Center of Core lbs. (kN)
1/4 (6.4)	Vertical	1/4" x 1-1/4"	1/4"	1-1/4 (31.8)	2,775 (12.3)	1,920 (8.5)
3/8 (9.5)	Vertical	1/4" x 1-1/2"	1/4"	1-1/2 (38.1)	3,700 (16.5)	2,570 (11.4)
1/2 (12.7)	Vertical	3/8" x 2-3/4"	3/8"	2-3/4 (69.9)	8,240 (36.7)	3,480 (15.5)

1. Tabulated load values are for anchors installed in 8-inch-thick hollow core plank with minimum compressive strength of 5,000 psi at the time of installation. The 4' x 6' normal-weight concrete members features include 1-1/2" cover above and below cores and a minimum web thickness of 1-1/2".
2. Depending on fastener application and governing building code, ultimate load capacities should be reduced by a minimum safety factor to determine the allowable working load. NFPA 13 Fire Protection requirements are 5 times the weight of the liquid (water) filled pipe plus 250 lbs. Consult the engineer of record.

## PERFORMANCE DATA

### Steel Vertigo – Ultimate Load Capacities for Factory Mutual (FM Global) and Underwriter’s Laboratories (UL) Listings<sup>1</sup>

Cat. No.	Anchor Size / Rod Diameter in. (mm)	Mount Direction	Screw Shank Size and Length	Point Style	Maximum Pipe Size in. (mm)	UL Minimum Steel Thickness in. (mm)	UL Test Load lbs. (kN)	FM Minimum Steel Thickness in. (mm)	FM Test Load lbs. (kN)
7158	3/8 (9.5)	Vertical	1/4-20 x 1"	#3	4 (101.6)	0.060 (1.5)	1,500 (6.8)	0.096 (2.4)	1,475 (6.6)
7184		Side	1/4-20 x 1"	#3	4 (101.6)	0.060 (1.5)	1,500 (6.8)	0.096 (2.4)	1,475 (6.6)
7160		Vertical	1/4-20 x 1-1/2"	#3	4 (101.6)	0.060 (1.5)	1,500 (6.8)	0.096 (2.4)	1,475 (6.6)
7186		Side	1/4-20 x 1-1/2"	#3	4 (101.6)	0.060 (1.5)	1,500 (6.8)	0.096 (2.4)	1,475 (6.6)
7154		Vertical	12-20 x 1-1/2"	#5	4 (101.6)	0.060 (1.5)	1,500 (6.8)	0.096 (2.4)	1,475 (6.6)
7188		Side	1/4-20 x 2"	#3	4 (101.6)	0.060 (1.5)	1,500 (6.8)	0.096 (2.4)	1,475 (6.6)
7201		Side	12-20 x 1-1/2"	#5	4 (101.6)	0.060 (1.5)	1,500 (6.8)	0.096 (2.4)	1,475 (6.6)
7161		1/2 (12.7)	Vertical	12-20 x 1-1/2"	#5	8 (203.2)	0.250 (6.4)	4,050 (18.2)	0.250 (6.4)

1. Steel Vertigo anchors are recommended to be installed with the Universal Steel & Wood Nut Driver. For UL and FM listings, Steel Vertigo must be installed with a retaining nut.

### Wood Vertigo – Ultimate Load Capacities for Factory Mutual (FM Global) and Underwriter’s Laboratories (UL) Listings<sup>1</sup>

Cat. No.	Anchor Size / Rod Diameter in. (mm)	Mount Direction	Screw Shank Size and Length	Embedment Depth in. (mm)	UL Maximum Pipe Size in. (mm)	UL Test Load lbs. (kN)	FM Maximum Pipe Size in. (mm)	FM Test Load lbs. (kN)
7165	3/8 (9.5)	Vertical	1/4 x 2"	2 (50.8)	3 (76.2)	1,050 (4.7)	-	-
7170		Side	1/4 x 2"	2 (50.8)	3 (76.2)	1,050 (4.7)	-	-
7167		Vertical	1/4 x 3"	3 (76.2)	3 (76.2)	1,050 (4.7)	-	-
7169		Vertical	1/4 x 4"	4 (101.6)	3 (76.2)	1,050 (4.7)	-	-
7162		Vertical	5/16" x 2-1/2"	2-1/2 (63.5)	4 (101.6)	1,500 (6.8)	4 (101.6)	1,475 (6.6)
7156		Vertical	5/16" x 2-1/2"	2-1/2 (63.5)	4 (101.6)	1,500 (6.8)	-	-
		Side	5/16" x 2-1/2"	2-1/2 (63.5)	4 (101.6)	1,500 (6.8)	-	-

1. Wood Vertigo anchors are recommended to be installed with the Universal Steel & Wood Nut Driver. No pre-drilling was done in the wood base materials.

### Concrete Vertigo – Ultimate Load Capacities for Factory Mutual (FM Global) Listings<sup>1</sup>

Cat. No.	Anchor Size / Rod Diameter in. (mm)	Mount Direction	Screw Shank Size and Length	ANSI Drill Bit Diameter d <sub>bit</sub> in.	Embedment Depth in. (mm)	FM Maximum Pipe Size in. (mm)	FM Test Load lbs. (kN)
7173	3/8 (9.5)	Vertical	1/4" x 1-1/2"	1/4"	1-1/2 (38.1)	4 (101.6)	1,475 (6.6)
7175	1/2 (12.7)	Vertical	3/8" x 2-3/4"	3/8"	2-3/4 (69.9)	4 (203.2)	3,800 (17.1)

1. Tabulated load values are for anchors installed in 8 inch thick hollow core plank with minimum compressive strength of 4,000 psi at the time of installation. The 4' x 6' normal-weight concrete

## ORDERING INFORMATION

### Steel Vertical Hanger (#3 for Purlins, #5 for Beams)

Cat. No.	Fastenal SKU	Rod Dia.	Screw Shank Size and Length	Point Style	Self Drilling Range	Std. Box	Std. Ctn.
7155	2140346	1/4"	1/4"-20 x 1"	#3	0.036" (20 gage) to 0.188" (3/16")	100	500
7157	2140348	3/8"	1/4"-20 x 2"	#3		100	500
7158	2140349	3/8"	1/4"-20 x 1" (w/nut)	#3		100	500
7159	2140350	3/8"	1/4"-20 x 1-1/2" (w/nut)	#3		100	500
7160	2140351	3/8"	1/4"-20 x 1-1/2" (w/nut)	#3		100	500
7152	2140344	1/4"	12"-20 x 1-1/2"	#5	0.188" (3/16") to 0.500" (1/2")	100	500
7154	2140344	3/8"	12"-20 x 1-1/2" (w/nut)	#5		100	500
7161	2140352	1/2"	12"-20 x 1-1/2" (w/nut)	#5		100	500

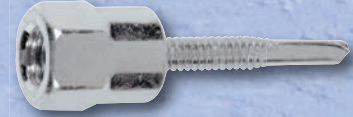

### Steel Side Hanger (#3 for Purlins, #5 for Beams)

Cat. No.	Fastenal SKU	Rod Dia.	Screw Shank Size and Length	Point Style	Self Drilling Range	Std. Box	Std. Ctn.
7183	2140364	1/4"	1/4"-20 x 1"	#3	0.036" (20 gage) to 0.188" (3/16")	100	500
7184	2140365	3/8"	1/4"-20 x 1" (w/nut)	#3		100	500
7186	2140367	3/8"	1/4"-20 x 1-1/2"	#3		100	500
7188	2140369	3/8"	1/4"-20 x 2" (w/nut)	#3		100	500
7200	2140373	1/4"	12"-20 x 1-1/2"	#5	0.188" (3/16") to 0.500" (1/2")	100	500
7201	2140374	3/8"	12"-20 x 1-1/2" (w/nut)	#5		100	100

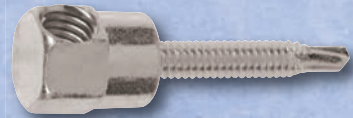

### Wood Vertical Hanger

Cat. No.	Fastenal SKU	Rod Dia.	Screw Shank Size and Length	Point Style	Pre-Drill Diameter (If Required)	Std. Box	Std. Ctn.
7163	2140354	1/4"	1/4" x 2"	Type 17	1/8"	100	500
7203	2140375	3/8"	1/4" x 1"	Type 17		100	500
7165	2140356	3/8"	1/4" x 2"	Type 17		100	500
7167	2140358	3/8"	1/4" x 3"	Type 17		100	500
7169	2140359	3/8"	1/4" x 4"	Type 17		100	500
7162	2140353	3/8"	5/16" x 2-1/2"	Type 17		100	500
7164	2140355	1/2"	5/16" x 2-1/2"	Type 17		100	500



### Wood Side Hanger

Cat. No.	Fastenal SKU	Rod Dia.	Screw Shank Size and Length	Point Style	Pre-Drill Diameter (If Required)	Std. Box	Std. Ctn.
7185	2140366	1/4"	1/4" x 1"	Type 17	1/8"	100	500
7205	2140376	3/8"	1/4" x 1"	Type 17		100	500
7170	2140360	3/8"	1/4" x 2"	Type 17		100	500
7156	2140347	3/8"	5/16" x 2-1/2"	Type 17		100	500

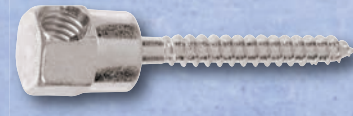

## ORDERING INFORMATION

### Concrete Vertical Hanger

Cat. No.	Fastenal SKU	Rod Dia.	Screw Shank Size and Length	Thread Style	Pre-Drill Diameter (If Required)	Std. Box	Std. Ctn.
7171	2140361	1/4"	1/4" x 1-1/4"	Wedge-Bolt OT	1/4" ANSI	100	500
7173	2140362	3/8"	1/4" x 1-1/2"	Wedge-Bolt OT	1/4" ANSI	100	500
7175	2140363	1/2"	1/4" x 2-3/4"	Wedge-Bolt OT	3/8" ANSI	50	250

### Drive Sockets and Pole Tool

Cat. No.	Fastenal SKU	Description	RPM	Std. Box	Std. Ctn.
7166	2140357	6'-12' Pole Tool (includes three Jaw Chuck)	N/A	1	1
7187	2140368	Universal Steel & Wood Socket (Red)	500 to 1500 RPM	5	25
7195	2140370	1/4" Concrete Socket (Blue)	-	5	25
7197	2140371	3/8" Concrete Socket (Blue)	-	5	25

### Concrete Vertigo Installation Accessories

Cat. No.	Fastenal SKU	Description	Maximum Bit Length	Std. Box	Std. Ctn.
5864	2141215	1/4" and 3/8" Concrete Drive Sockets (Blue) Universal Steel & Wood Socket (Red) (Sleeve Assembly (same as Cat# 5874)	6"	1	3/4
5874	2141214	Sleeve Assembly	6"	1	-
Cat. No.	Description		Usable Length	Std. Tube	Wt./10
5860	1/4" x 4-1/2" Straight Shank Drill Bit		3"	5	1/2
5866	Hex Shank SDS Drill Bit Straight Shank Drill Bit		4"	1	1/2

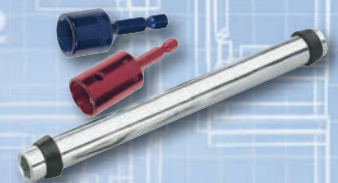
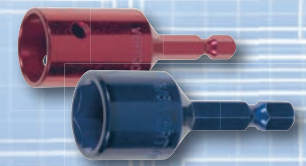

# Vertigo+™



## INTERNAL THREAD VERSION

Unified coarse thread (UNC)

## ANCHOR MATERIALS

Zinc Plated Carbon Steel  
(Yellow Dichromate Finish)

## ROD/ANCHOR SIZE RANGE (TYP.)

1/4" diameter through 1/2" diameter

## SUITABLE BASE MATERIALS

Normal-weight concrete  
Structural sand-lightweight concrete  
Concrete over steel deck



## PRODUCT DESCRIPTION

Vertigo+ is a one piece, all steel threaded fastening system for suspending threaded in pipe hanging, fire protection, electrical conduit and cable-tray applications. They can be installed in a variety of base materials including normal-weight concrete, structural sand-lightweight concrete and concrete over steel deck. Vertigo+ accepts threaded rods and bolts in 1/4", 3/8", and 1/2" diameters. Vertigo+ anchors are designed for simple fast installations and reliable performance in cracked and uncracked concrete.

## TESTING AND EVALUATION

- Hanging Pipe and Sprinkler Systems
- Lighting Systems and Overhead Utilities
- Suspended Ceilings
- Suspending Conduit and Cable Trays
- HVAC Ductwork and Strut Channels

## FEATURES AND BENEFITS

- Simple system for all rod hanging applications in concrete
- Internally threaded coupler for easy removability of service items
- Ease and speed of installation and attachment
- Lower in-place cost, when compared to traditional anchors
- Can be installed with an adjustable torque impact driver
- Consistent performance in high and low strength concrete

## APPROVALS AND LISTINGS

International Code Council, Evaluation Service (ICC-ES). ESR-2989 code compliant with the 2009 IBC, 2009 IRC, 2006 IBC, 2003 IBC, 2003 IRC and 1997 UBC  
Tested in accordance with ACI 355.2 and ICC-ES AC193 for use in structural concrete under the design provisions of ACI 318 (Strength Design method using Appendix D)  
Evaluated and qualified by an accredited independent testing laboratory for recognition in cracked and uncracked concrete including seismic and wind loading (Category 1 anchors)  
Evaluated and qualified by an accredited independent testing laboratory for reliability against brittle failure, e.g. hydrogen embrittlement  
Evaluated and qualified by an accredited independent testing laboratory for supplemental recognition in redundant fastening applications

## GUIDE SPECIFICATIONS

**CSI Divisions:** 03151-Concrete Anchoring, 05090-Metal Fastenings.  
Anchors shall be Vertigo+ as supplied by Powers Fasteners, Inc., Brewster, NY.  
Anchors shall be installed in accordance with published instruction and the Authority Having Jurisdiction.

## MATERIAL SPECIFICATIONS

Anchor Component	Specification
Anchor body / Coupler head	Case hardened low carbon steel
Plating	Zinc plating according to ASTM B 633 SC1, Type II (Fe/Zn5) Minimum plating requirement for Mild Service Condition

## INSTALLATION SPECIFICATIONS

### Installation Table for Vertigo+

Anchor Property/ Setting Information	Symbol	Units	Nominal Anchor Size / Threaded Coupler Diameter (in.)		
			1/4	3/8	1/2
Nominal anchor shank diameter	$d_o$	in.	0.375 (9.5)	0.375 (9.5)	0.375 (9.5)
Nominal drill bit diameter	$d_{bit}$	in.	3/8 Wedge-bit	3/8 Wedge-bit	3/8 Wedge-bit
Wedge-bit tolerance range	-	in.	0.385 to 0.389	0.385 to 0.389	0.385 to 0.389
Nominal embedment depth	$h_{nom}$	in. (mm)	2-1/8 (50.8)	2-1/8 (50.8)	2-1/8 (50.8)
Effective embedment	$h_{ef}$	in. (mm)	1.425 (36)	1.425 (36)	1.425 (36)
Minimum hole depth	$h_o$	in. (mm)	2-1/2 (64)	2-1/2 (64)	2-1/2 (64)
Minimum member thickness <sup>1,2</sup>	$h_{min}$	in. (mm)	4 (102)	4 (102)	4 (102)
Overall anchor length	$l_{anch}$	in. (mm)	3 (76)	3 (76)	3 (76)
Minimum edge distance <sup>1,2</sup>	$c_{min}$	in. (mm)	1-3/4 (44)	1-3/4 (44)	1-3/4 (44)
Minimum spacing distance <sup>1,2</sup>	$s_{min}$	in. (mm)	2-1/2 (64)	2-1/2 (64)	2-1/2 (64)
Critical edge distance <sup>1,2</sup>	$c_{ac}$	in. (mm)	2-3/4 (70)	2-3/4 (70)	2-3/4 (70)
Maximum impact wrench power (torque)	$T_{screw}$	ft.-lb. (N-m)	185 (250)	185 (250)	185 (250)
Impact wrench / socket size	$d_h$	in.	11/16	11/16	11/16
Head height	-	in.	3/4	3/4	3/4

For SI: 1 inch = 25.4 mm,  
1 ft-lbf = 1.356 N-m

- For installations through the soffit of steel deck into concrete, see the installation detail. Anchors in the lower flute may be installed with a maximum 1-inch offset in either direction from center of the flute. In addition, anchors shall have an axial spacing along the flute equal to the greater of  $3h_w$  or 1.5 times the flute width.
- For use with the design provisions of ACI 318 Appendix D.

### Matched Tolerance System



Designed and tested as a system for consistency and reliability



### Vertigo+ Anchor Detail in Concrete

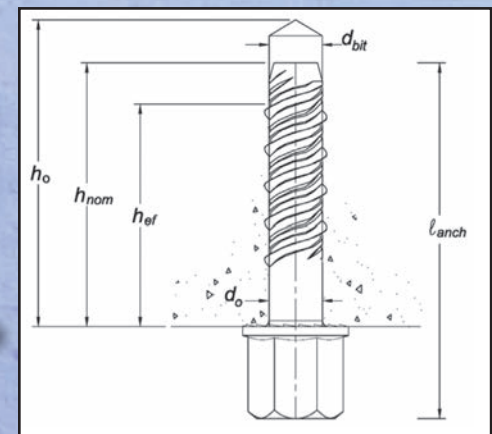

## ORDERING INFORMATION

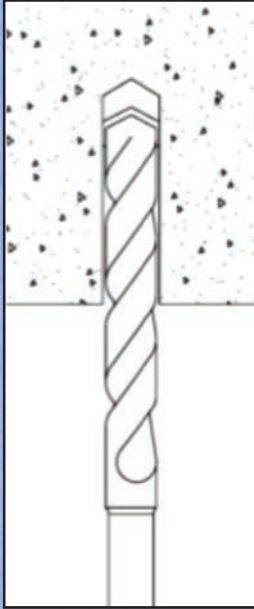

1.) Using the proper Wedge-bit size, drill a hole into the base material to the required depth. The tolerances of the Wedge-bit used must meet the requirements of the published Wedge-bit range.

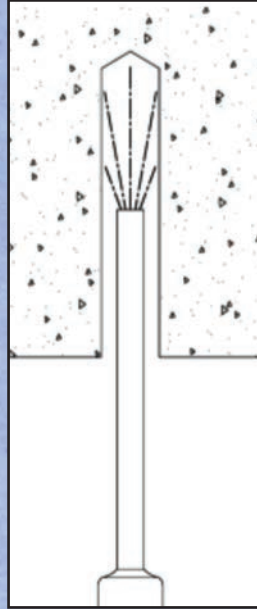

2.) Remove dust and debris from the hole

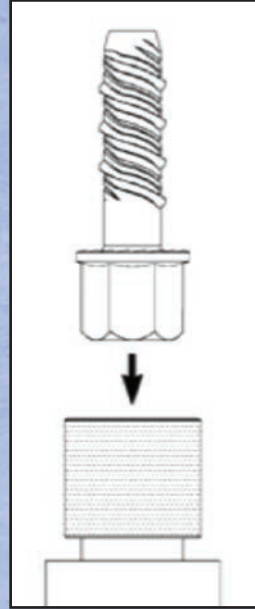

3.) Select a powered impact wrench that does not exceed the maximum torque, screw, for the selected anchor diameter. Attach an appropriate sized hex socket/driver to the impact wrench. Mount the screw anchor head into the socket.

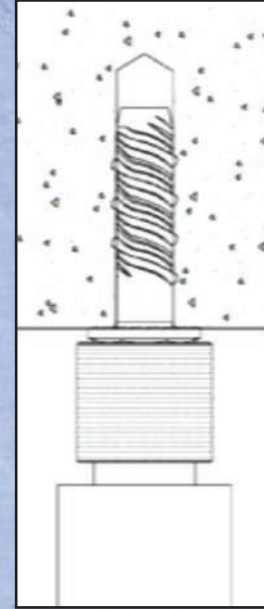

4.) Drive the anchor into the hole until the head of the anchor comes into contact with the member surface. The anchor should be snug after installation. Do not spin the hex socket off the anchor to disengage. Insert threaded rod or bolt into Vertigo+.

## Installation Detail for Vertigo+ Installed Through Soffit or Steel Deck into Concrete

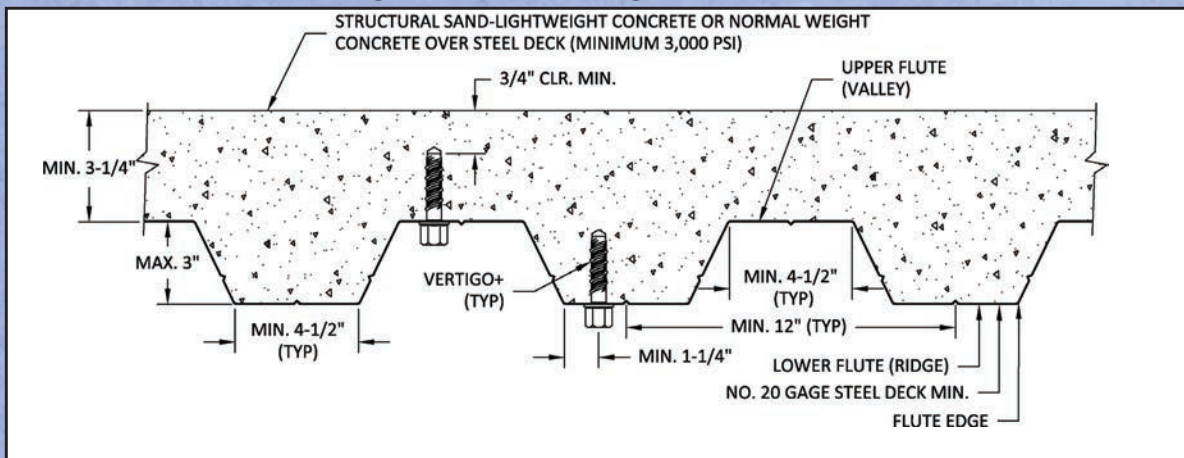

## INSTALLATION INSTRUCTION

### Tension Design Information For Vertigo+ Anchors in Concrete

(For use with load combinations taken from ACI 318 Section 9.2)<sup>1,2</sup>

Design Characteristic	Notation	Units	Nominal Anchor Size / Threaded Coupler Diameter (in.)		
			1/4	3/8	1/2
Anchor category	1, 2 or 3	-	1	1	1
Nominal embedment depth	$h_{nom}$	in.	2-1/8	2-1/8	2-1/8
<b>STEEL STRENGTH IN TENSION<sup>4</sup></b>					
Minimum specified yield strength of steel insert element (threaded rod or bolt)	$f_y$	ksi (N/mm <sup>2</sup> )	36.0 (248)	36.0 (248)	36.0 (248)
Minimum specified ultimate strength of steel insert element (threaded rod or bolt)	$f_{uta}^{11}$	ksi (N/mm <sup>2</sup> )	58.0 (400)	58.0 (400)	58.0 (400)
Effective tensile stress area of steel insert element (threaded rod or bolt)	$A_{se,N} [A_{se}]^{12}$	in <sup>2</sup> (mm <sup>2</sup> )	0.0318 (20.5)	0.0775 (50)	0.1419 (91.6)
Steel strength in tension	$N_{sa}^{11}$	lb (kN)	1,845 (8.2)	4,495 (20)	8,230 (36.6)
Reduction factor for steel strength <sup>3</sup>	$\phi$	-	0.65	0.65	0.65
<b>CONCRETE BREAKOUT IN TENSION<sup>8</sup></b>					
Effective embedment	$h_{ef}$	in. (mm)	1.425 (36)	1.425 (36)	1.425 (36)
Effectiveness factor for uncracked concrete	$k_{uncr}$	-	24	24	24
Effectiveness factor for cracked concrete	$k_{cr}$	-	17	17	17
Modification factor for cracked and uncracked concrete <sup>5</sup>	$C_{c,N}^{11}$	-	1 See note 5	1 See note 5	1 See note 5
Critical edge distance	$c_{ec}$	in. (mm)	2-3/4 (70)	2-3/4 (70)	2-3/4 (70)
Reduction factor for concrete breakout strength <sup>3</sup>	$\phi$	-	0.65 (Condition B)		
<b>PULLOUT STRENGTH IN TENSION (NON-SEISMIC APPLICATIONS)<sup>8</sup></b>					
Characteristic pullout strength, uncracked concrete (2,500 psi) <sup>6</sup>	$N_{p,uncr}$	lb (kN)	See note 7	See note 7	See note 7
Characteristic pullout strength, cracked concrete (2,500 psi) <sup>6</sup>	$N_{p,cr}$	lb (kN)	See note 7	See note 7	See note 7
Reduction factor for pullout strength <sup>3</sup>	$\phi$	-	0.65 (Condition B)		
<b>PULLOUT STRENGTH IN TENSION FOR SEISMIC APPLICATIONS<sup>8</sup></b>					
Characteristic pullout strength, seismic (2,500 psi) <sup>6,9</sup>	$N_{eq}^{11}$	lb (kN)	1,085 (4.8)	1,085 (4.8)	1,085 (4.8)
Reduction factor for pullout strength <sup>3</sup>	$\phi$	-	0.65 (Condition B)		
<b>PULLOUT STRENGTH IN TENSION FOR STRUCTURAL SAND-LIGHTWEIGHT AND NORMAL-WEIGHT CONCRETE OVER STEEL DECK</b>					
Characteristic pullout strength, uncracked concrete over steel deck <sup>6,10</sup>	$N_{p,deck,uncr}$	lb (kN)	1,990 (8.9)	1,990 (8.9)	1,990 (8.9)
Characteristic pullout strength, cracked concrete over steel deck <sup>6,10</sup>	$N_{p,deck,cr}$	lb (kN)	1,410 (6.3)	1,410 (6.3)	1,410 (6.3)
Characteristic pullout strength, cracked concrete over steel deck seismic <sup>6,10</sup>	$N_{p,deck,eq}$	lb (kN)	1,060 (4.7)	1,060 (4.7)	1,060 (4.7)
Reduction factor for pullout strength <sup>3</sup>	$\phi$	-	0.65 (Condition B)		

- The data in this table is intended to be used with the design provisions of ACI 318 Appendix D; for anchors resisting seismic load combinations the additional requirements of ACI 318 D.3.3 must apply.
- Installation must comply with printed instructions.
- All values of  $\phi$  were determined from the load combinations of UBC Section 1605.2.1, UBC Section 1612.2.1, or ACI 318 Section 9.2. If the load combinations of UBC Section 1902.2 or ACI 318 Appendix C are used, the appropriate value of  $\phi$  must be determined in accordance with ACI 318 D.4.5. For reinforcement that meets ACI 318 Appendix D requirements for Condition A, see ACI 318 D.4.4 for the appropriate  $\phi$  factor.
- It is assumed that the threaded rod or bolt used with the Vertigo+ anchor will be a ductile steel element as defined by ACI 318 D.1.
- For all design cases use  $C_{se} = 1.0$ . The appropriate effectiveness factor for cracked concrete ( $k_{cr}$ ) and uncracked concrete ( $k_{uncr}$ ) must be selected.
- For all design cases use  $C_{cp} = 1.0$ . For concrete compressive strength greater than 2,500 psi,  $N_{sa} = (\text{Pullout strength value from table}) \times (\text{specified concrete compressive strength} / f_{cm})^{0.5}$  where the value of  $f_{cm}$  is 2500 except in concrete over steel deck where the value of  $f_{cm}$  is 3000.
- Pullout strength does not control design of indicated anchors. Do not calculate pullout strength for indicated anchor size and embedment.
- Anchors are permitted to be used in structural sand-lightweight concrete provided that  $N_{sa}$ ,  $N_{cr}$ , and  $N_{eq}$  are multiplied by a factor of 0.60 (not required for steel deck).
- Tabulated values for characteristic pullout strength in tension are for seismic applications and based on test results in accordance with ACI 355.2, Section 9.5.
- Values for  $N_{deck}$  are for structural sand-lightweight concrete ( $f'_{cm} = 3,000$  psi) and additional lightweight concrete reduction factors need not be applied. In addition, evaluation for the concrete breakout capacity in accordance with ACI 318 D.5.2 is not required for anchors installed in the flute (soffit).
- For 2003 IBC,  $f_{cr}$  replaces  $f_y$ ;  $N_{sa}$  replaces  $N_s$ ;  $C_{cr}$  replaces  $C_s$ ; and  $C_{se}$  replaces  $N_{se}$ .
- The notation in brackets is for the 2006 IBCB.

## PERFORMANCE DATA

### Shear Design Information For Vertigo+ Anchors in Concrete

(For use with load combinations taken from ACI 318 Section 9.2)<sup>1,2</sup>

Design Characteristic	Notation	Units	Nominal Anchor Size / Threaded Coupler Diameter (in.)		
			1/4"	3/8"	1/2"
Anchor category	1, 2 or 3	-	1	1	1
Nominal embedment depth	$h_{nom}$	in.	2-1/8	2-1/8	2-1/8
<b>STEEL STRENGTH IN SHEAR<sup>4</sup></b>					
Steel strength in shear <sup>5</sup>	$V_{sa}^{10}$	lb (kN)	1,105 (4.9)	2,695 (12)	3,075 (13.7)
Reduction factor for steel strength <sup>3</sup>	$\phi$	-	0.60	0.60	0.60
<b>CONCRETE BREAKOUT IN SHEAR<sup>4</sup></b>					
Load bearing length of anchor ( $h_{ef}$ or $8d_o$ , whichever is less)	$l_e^{10}$	in. (mm)	1.425 (36)	1.425 (36)	1.425 (36)
Nominal anchor diameter	$d_a [d_o]^{11}$	in. (mm)	0.375 (9.5)	0.375 (9.5)	0.375 (9.5)
Reduction factor for concrete breakout strength <sup>2</sup>	$\phi$	-	0.70 (Condition B)		
<b>PRYOUT STRENGTH IN SHEAR<sup>6</sup></b>					
Coefficient for pryout strength (1.0 for $h_{ef} < 2.5$ in, 2.0 for $h_{ef} \geq 2.5$ in)	$k_{cp}$	-	1	1	1
Reduction factor for pryout strength <sup>3</sup>	$\phi$	-	0.70 (Condition B)		
<b>STEEL STRENGTH IN SHEAR FOR SEISMIC APPLICATIONS</b>					
Steel strength in shear, seismic <sup>7</sup>	$V_{eq}^{10}$	lb (kN)	1,105 (4.9)	2,000 (8.9)	2,000 (8.9)
Reduction factor for steel strength in shear for seismic applications <sup>3</sup>	$\phi$	-	0.60	0.60	0.60
<b>STEEL STRENGTH IN SHEAR FOR STRUCTURAL SAND-LIGHTWEIGHT AND NORMAL-WEIGHT CONCRETE OVER STEEL DECK<sup>9</sup></b>					
Steel strength in shear, concrete over steel deck <sup>8</sup>	$V_{sa,deck}$	lb (kN)	1,105 (4.9)	1,975 (8.8)	2,495 (11.1)
Steel strength in shear, concrete over steel deck seismic <sup>8</sup>	$V_{sa,deck,eq}$	lb (kN)	1,105 (4.9)	1,480 (6.6)	1,620 (7.2)
Reduction factor for steel strength in shear for steel deck applications <sup>3</sup>	$\phi$	-	0.60	0.60	0.60

For SI: 1 inch = 25.4 mm.

- The data in this table is intended to be used with the design provisions of ACI 318 Appendix D; for anchors resisting seismic load combinations the additional requirements of ACI 318 D.3.3 shall apply.
- Installation must comply with published instructions and details.
- All values of  $\phi$  were determined from the load combinations of UBC Section 1605.2.1, UBC Section 1612.2.1, or ACI 318 Section 9.2. If the load combinations of UBC Section 1902.2 or ACI 318 Appendix C are used, the appropriate value of  $\phi$  must be determined in accordance with ACI 318 D.4.5. For reinforcement that meets ACI 318 Appendix D requirements for Condition A, see ACI 318 D.4.4 for the appropriate  $\phi$  factor.
- It is assumed that the threaded rod or bolt used with the Vertigo+ anchor will be a ductile steel element as defined by ACI 318 D.1.
- Tabulated values for steel strength in shear must be used for design. These tabulated values are lower than calculated results using equation D-20 in ACI 318-05 D.6.1.2 and D-18 in ACI 318-02, D.6.1.2.
- Anchors are permitted to be used in structural sand-lightweight concrete provided that  $V_b$  and  $V_{cp}$  are multiplied by a factor of 0.60 (not required for steel deck).
- Reported values for steel strength in shear for seismic applications are based on test results per ACI 355.2 Section 9.6.
- Values for  $V_{sa,deck}$  are for structural sand-lightweight concrete ( $f'_{cm} = 3,000$  psi) and additional lightweight concrete reduction factors need not be applied. In addition, evaluation for the concrete breakout capacity in accordance with ACI 318 D.6.2 and the pryout capacity in accordance with ACI 318 D.6.3 are not required for anchors installed in the flute (soffit).
- Shear loads for anchors installed through steel deck into concrete may be applied in any direction.
- For 2003 IBC,  $f_{sa}$  replaces  $f_s$ ;  $V_{sa}$  replaces  $V_s$ ;  $\phi_s$  replaces  $\phi$ ; and  $V_{sa,eq}$  replaces  $V_{s,eq}$ .
- The notation in brackets is for the 2006 IBC.

## FACTORED DESIGN STRENGTH ( $\phi N_n$ AND $\phi V_n$ ) CALCULATED IN ACCORDANCE WITH ACI 318 APPENDIX D:

- Tabular values are provided for illustration and are applicable for single anchors installed in normal-weight concrete with minimum slab thickness,  $h_e = h_{min}$ , and with the following conditions:
  - $c_{a1}$  is greater than or equal to the critical edge distance,  $c_{ac}$  (table values based on  $c_{a1} = c_{ac}$ ).
  - $c_{a2}$  is greater than or equal to  $1.5 c_{a1}$ .
- Calculations were performed according to ACI 318-05 Appendix D. The load level corresponding to the controlling failure mode is listed. (e.g. For tension: steel, concrete breakout and pullout; For shear: steel, concrete breakout and pryout). Furthermore, the capacities for concrete breakout strength in tension and pryout strength in shear are calculated using the effective embedment values,  $h_{ef}$ , for the selected anchors as noted in the design information tables. Please also reference the installation specifications for more information.
- Strength reduction factors ( $\phi$ ) were based on ACI 318 Section 9.2 for load combinations. Condition B is assumed.
- Tabular values are permitted for static loads only, seismic loading is not considered with these tables.
- For designs that include combined tension and shear, the interaction of tension and shear loads must be calculated in accordance with ACI 318 Appendix D.
- Interpolation is not permitted to be used with the tabular values. For intermediate base material compressive strengths please see ACI 318 Appendix D. For other design conditions including seismic considerations please see ACI 318 Appendix D.

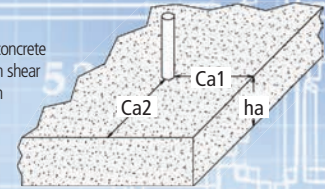

### Tension and Shear Design Strength for Vertigo+ in Cracked Concrete

Nominal Anchor Size (in.)	Nominal Embed. $h_{nom}$ (in.)	Steel Insert Element (Threaded Rod or Bolt)	Minimum Concrete Compressive Strength, $f'_c$ (psi)									
			2,500		3,000		4,000		6,000		8,000	
			$\phi N_n$ Tension (lbs.)	$\phi V_n$ Shear (lbs.)	$\phi N_n$ Tension (lbs.)	$\phi V_n$ Shear (lbs.)	$\phi N_n$ Tension (lbs.)	$\phi V_n$ Shear (lbs.)	$\phi N_n$ Tension (lbs.)	$\phi V_n$ Shear (lbs.)	$\phi N_n$ Tension (lbs.)	$\phi V_n$ Shear (lbs.)
1/4	2-1/8	$f_u \geq 58\text{ksi}$	940	665	1,030	665	1,190	665	1,200	665	1,200	665
3/8	2-1/8		940	940	1,030	1,030	1,190	1,190	1,460	1,460	1,685	1,615
1/2	2-1/8		940	1,015	1,030	1,110	1,190	1,280	1,460	1,570	1,685	1,810

### Tension and Shear Design Strength for Vertigo+ in Uncracked Concrete

Nominal Anchor Size (in.)	Nominal Embed. $h_{nom}$ (in.)	Steel Insert Element (Threaded Rod or Bolt)	Minimum Concrete Compressive Strength, $f'_c$ (psi)									
			2,500		3,000		4,000		6,000		8,000	
			$\phi N_n$ Tension (lbs.)	$\phi V_n$ Shear (lbs.)	$\phi N_n$ Tension (lbs.)	$\phi V_n$ Shear (lbs.)	$\phi N_n$ Tension (lbs.)	$\phi V_n$ Shear (lbs.)	$\phi N_n$ Tension (lbs.)	$\phi V_n$ Shear (lbs.)	$\phi N_n$ Tension (lbs.)	$\phi V_n$ Shear (lbs.)
1/4	2-1/8	$f_u \geq 58\text{ksi}$	1,200	665	1,200	665	1,200	665	1,200	665	1,200	665
3/8	2-1/8		1,300	1,320	1,455	1,455	1,680	1,615	2,060	1,615	2,375	1,615
1/2	2-1/8		1,300	1,430	1,455	1,565	1,680	1,810	2,060	1,845	2,375	1,845

Steel Strength Controls
  Concrete Breakout Strength Controls
  Anchor Pullout / Pryout

## REDUNDANT FASTENING APPLICATIONS

For an anchoring system designed with redundancy, the load maintained by an anchor that experiences failure or excessive deflection can be transmitted to neighboring anchors without significant consequences to the fixture or remaining resistance of the anchoring system. In addition to the requirements for anchors, the fixture being attached shall be able to resist the forces acting on it assuming one of the fixing points is not carrying load. It is assumed that by adhering to the limits placed on  $n_1$ ,  $n_2$  and  $n_3$  below, redundancy will be satisfied.

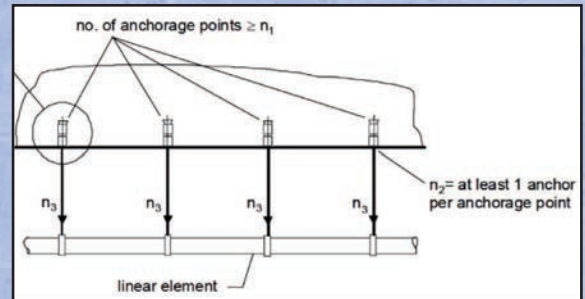

Anchors qualified for redundant applications may be designed for use in normal weight and sand-lightweight cracked and uncracked concrete. Concrete compressive strength of 2,500 psi shall be used for design. No increase in anchor capacity is permitted for concrete compressive strengths greater than 2,500 psi. The anchor installation is limited to concrete with a compressive strength of 8,500 psi or less.

Redundant applications shall be limited to structures assigned to Seismic Design Categories A or B only.

Redundant applications shall be limited to support of nonstructural elements.

### Strength Design (Redundant Fastening):

For strength design, a redundant system is achieved by specifying and limiting the following variables  
 $n_1$  = the total number of anchorage points supporting the linear element  
 $n_2$  = number of anchors per anchorage point  
 $n_3$  = factored load at each anchorage point, lbs., using load combinations from IBC Section 1605.2.1 or ACI 318 Section 9.2

### Allowable Stress Design (Redundant Fastening):

Design values for use with allowable stress design shall be established taking  $R_d, ASD = \frac{\phi_{ra} \cdot F_{ra}}{\alpha}$

Where  $\alpha$  is the conversion factor calculated as the weighted average of the load factors from the controlling load combination. The conversion factor,  $\alpha$  is equal to 1.4 assuming all dead load.

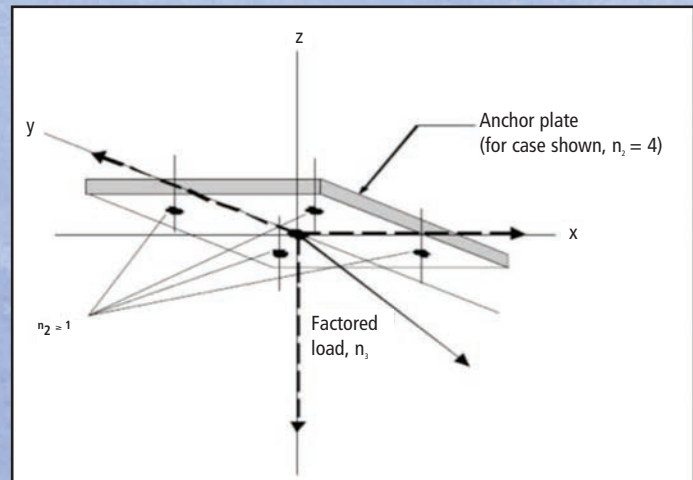

## INSTALLATION SPECIFICATIONS

### Installation Table for Vertigo+ Anchor in Redundant Fastening Applications

Anchor Property/ Setting Information	Symbol	Units	Nominal Anchor Size / Threaded Coupler Diameter (in.)		
			1/4	3/8	1/2
Nominal anchor shank diameter	$d_o$	in. (mm)	0.375 (9.5)	0.375 (9.5)	0.375 (9.5)
Nominal drill bit diameter	$d_{bit}$	in.	3/8" Wedge-bit	3/8" Wedge-bit	3/8" Wedge-bit
Wedge-bit tolerance range	-	in.	0.385 to 0389	0.385 to 0389	0.385 to 0389
Minimum nominal embedment depth	$h_{nom}$	in. (mm)	2-1/8 (50.8)	2-1/8 (50.8)	2-1/8 (50.8)
Effective embedment	$h_{ef}$	in. (mm)	1.425 (36)	1.425 (36)	1.425 (36)
Minimum hole depth	$h_o$	in. (mm)	2-1/2 (64)	2-1/2 (64)	2-1/2 (64)
Minimum member thickness	$h_{min}$	in. (mm)	3 (76.2)	3 (76.2)	3 (76.2)
Overall anchor length	$l_{anch}$	in. (mm)	3 (76)	3 (76)	3 (76)
Minimum edge distance	$c_{min}$	in. (mm)	4 (102)	4 (102)	4 (102)
Minimum spacing distance	$s_{min}$	in. (mm)	8 (204)	8 (204)	8 (204)
Maximum impact wrench power (torque)	$T_{screw}$	ft.-lb. (N-m)	245 (332)	245 (332)	245 (332)
Impact wrench/socket size	$d_h$	in.	11/16	11/16	11/16
Head height	-	in.	3/4	3/4	3/4

## PERFORMANCE DATA FOR REDUNDANT FASTENING APPLICATIONS

### Redundant Fastening Design Information for Vertigo+ Anchors in Normal Weight Concrete and for Sand-Lightweight and Normal Weight Concrete Over Steel Deck<sup>1,2,3,4,5,6</sup>

Design Characteristic	Notation	Units	Nominal Anchor Size / Threaded Coupler Diameter (in.)					
			1/4		3/8		1/2	
Anchor category	1, 2 or 3	-	1		1		1	
<b>CHARACTERISTIC DESIGN STRENGTH (RESISTANCE) IN CRACKED OR UNCRACKED CONCRETE<sup>4,5,6</sup></b>								
Resistance, cracked or uncracked concrete (2,500psi)	$F_{ra}$	lb (kN)	Number of anchorage points		Number of anchorage points		Number of anchorage points	
			$n_1 \geq 4$	$n_1 \geq 3$	$n_1 \geq 4$	$n_1 \geq 3$	$n_1 \geq 4$	$n_1 \geq 3$
			675 (3.0)	450 (2.0)	675 (3.0)	450 (2.0)	675 (3.0)	450 (2.0)
Strength reduction factor	$f_{ra}$	-	0.65		0.65		0.65	

- The data in this table is intended to be used with the design provisions of this product; loads may be applied in any direction.
- Installation must comply with published instructions and details.
- All values of  $\phi$  were determined from the load combinations of UBC Section 1605.2.1, UBC Section 1612.2.1, or ACI 318 Section 9.2.
- It is assumed that the threaded rod or bolt used with the Vertigo+ anchor has minimum specified properties as listed in the table above or an equivalent steel element.
- Anchors are permitted to be used in structural sand-lightweight concrete provided the resistance value is multiplied by 0.6.
- For installations through the soffit of steel deck into concrete see the installation detail. Anchors in the lower flute may be installed with a maximum 1-inch offset in either direction from center of the flute. In addition, anchors shall have an axial spacing along the flute equal to the greater of  $3h_{ef}$  or 1.5 times the flute width.

## PERFORMANCE DATA (ALLOWABLE STRESS DESIGN)

### Ultimate Load Capacities for Vertigo+ in Normal-Weight Concrete<sup>1,2</sup>



Nominal Anchor Size / Threaded Coupler Diameter in. (mm)	Nominal Anchor Shank Diameter d <sub>o</sub> in. (mm)	Minimum Embedment Depth h <sub>nom</sub> in. (mm)	Minimum Concrete Compressive Strength f' <sub>c</sub>							
			2,500 psi (17.2 MPa)		3,000 psi (20.7 MPa)		4,000 psi (27.6 MPa)		6,000 psi (41.4 MPa)	
			Tension lbs. (kN)	Shear lbs. (kN)	Tension lbs. (kN)	Shear lbs. (kN)	Tension lbs. (kN)	Shear lbs. (kN)	Tension lbs. (kN)	Shear lbs. (kN)
1/4 (6.3)	3/8 (9.5)	2-1/8 (54.0)	3,260 (14.5)	2,850 (12.7)	3,570 (15.9)	2,850 (12.7)	4,205 (18.8)	2,850 (12.7)	5,150 (23.0)	2,850 (12.7)
3/8 (9.5)	3/8 (9.5)	2-1/8 (54.0)	3,260 (14.5)	4,235 (18.9)	3,570 (15.9)	4,235 (18.9)	4,205 (18.8)	4,235 (18.9)	5,150 (23.0)	4,235 (18.9)
1/2 (12.7)	3/8 (9.5)	2-1/8 (54.0)	3,260 (14.5)	4,235 (18.9)	3,570 (15.9)	4,235 (18.9)	4,205 (18.8)	4,235 (18.9)	5,150 (23.0)	4,235 (18.9)

1. Tabulated load values are for anchors installed in concrete. Concrete compressive strength must be at the specified minimum at the time of installation.
2. Ultimate load capacities must be reduced by a minimum safety factor of 4.0 or greater to determine allowable working load.

### Allowable Load Capacities for Vertigo+ in Normal-Weight Concrete<sup>1</sup>

Nominal Anchor Size / Threaded Coupler Diameter in. (mm)	Nominal Anchor Shank Diameter d <sub>o</sub> in. (mm)	Minimum Embedment Depth h <sub>nom</sub> in. (mm)	Minimum Concrete Compressive Strength f' <sub>c</sub>							
			2,500 psi (17.2 MPa)		3,000 psi (20.7 MPa)		4,000 psi (27.6 MPa)		6,000 psi (41.4 MPa)	
			Tension lbs. (kN)	Shear lbs. (kN)	Tension lbs. (kN)	Shear lbs. (kN)	Tension lbs. (kN)	Shear lbs. (kN)	Tension lbs. (kN)	Shear lbs. (kN)
1/4 (6.3)	3/8 (9.5)	2 1/8 (54.0)	815 (3.6)	485 (2.2)	890 (4.0)	485 (2.2)	1,050 (4.7)	485 (2.2)	1,290 (5.7)	485 (2.2)
3/8 (9.5)	3/8 (9.5)	2 1/8 (54.0)	815 (3.6)	1,060 (4.7)	890 (4.0)	1,060 (4.7)	1,050 (4.7)	1,060 (4.7)	1,290 (5.7)	1,060 (4.7)
1/2 (12.7)	3/8 (9.5)	2 1/8 (54.0)	815 (3.6)	1,060 (4.7)	890 (4.0)	1,060 (4.7)	1,050 (4.7)	1,060 (4.7)	1,290 (5.7)	1,060 (4.7)

1. Allowable load capacities are calculated using an applied safety factor of 4.0.



## ORDERING INFORMATION

### Vertigo+ Rod Hanger (Carbon Steel w/Blue Tip)

Cat. No.	Rod Dia.	Screw Shank Size and Length	Thread Style	Pre-Drill Diameter	Std. Box	Std. Ctn.
7180SD	1/4"	3/8" x 2-1/8"	Wedge-Bolt+	3/8" Wedge-Bit	50	250
7181SD	3/8"					
7182SD	1/2"					

An SDS 3/8" x 6" Wedge-Bit (Cat# 01316 is included in each box of Vertigo+)

### Wedge-Bits

Cat. No.	Wedge-Bit Description	Usable Length	Std. Box	Std. Ctn.
01316	SDS 3/8" x 6"	4"	1	1
01380	HD Straight Shank 3/8" x 6"	4"	5	25

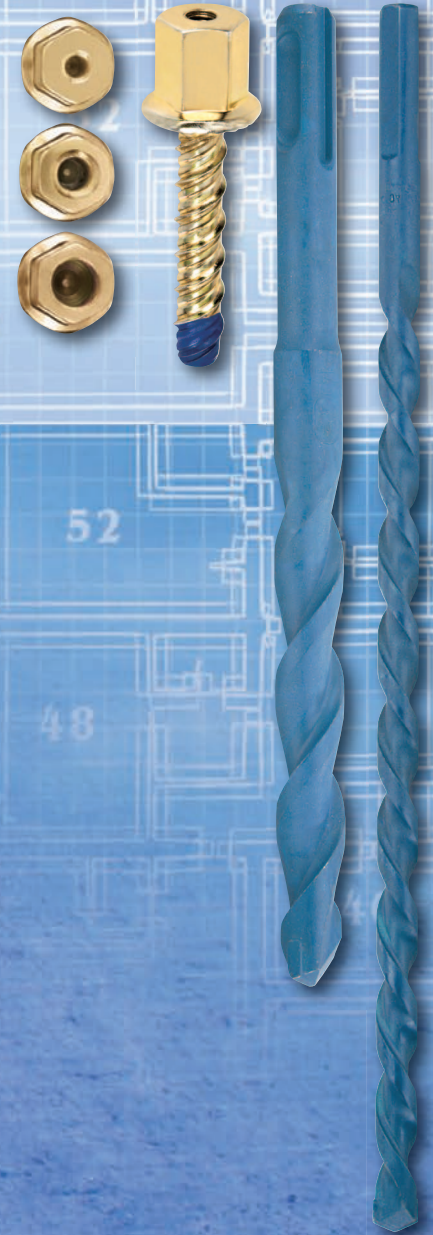

## POWERS FASTENERS BRANCH INFORMATION

## USA LOCATIONS

CITY	ADDRESS	CONTACT	PHONE	FAX
Alabama	5405 Buford Hwy Suite 410 Norcross, GA 30071-3984	Jeff Hatchett	205-520-6044	678-966-9242
Atlanta	5405 Buford Hwy Suite 410 Norcross, GA 30071-3984	Ryan Raica	678-966-0000	678-966-9242
Boston	2 Powers Lane, Brewster, NY 10509	Jack Armour	800-524-3244	914-576-6483
Charlotte	349 L West Tremont Avenue, Charlotte, NC 28203	Bob Aurisy	704-375-5012	704-376-5517
Chicago	2472 Wisconsin Avenue, Downers Grove, IL 60515	Dan Gilligan	630-960-3156	630-960-3912
Dallas	1300 IH 35 North, Suite #118, Carrollton TX 75006	Matt Henderson	972-506-9258	972-506-9290
Denver	2475 West Second Street #35, Denver, CO 80223	Jared Hemmert	303-922-9202	303-922-9228
Detroit	21600 Wyoming Avenue, Oak Park, MI 48237	Glen Gaskill	248-543-8600	248-543-8601
Florida	2412 Lynx Lane, Orlando, FL 32804	John Christy	813-626-4500	813-626-4545
Houston	13833 North Promenade, Suite 100, Stafford, TX 77477	Vaughn Eshelman	281-491-0351	281-491-0367
Indianapolis	15290 Stony Creek Way, Noblesville, IN 46060	Bill Trainor	317-773-1668	317-773-1690
Kansas City / St Louis	716 East 16th Avenue, North Kansas City, MO 64116	Don James, Jr.	816-472-5038	816-472-5040
Los Angeles	2761 Dow Avenue, Tustin, CA 92780	Trevor Gillespie	714-731-2500	714-731-2566
Maryland	3137-B Penny Drive, Landover, MD 20785	Chris Van Syckle	301-773-1722	301-341-5119
Milwaukee	12020 W. Feerick Street, Milwaukee, WI 53222	Donn Raduencz	414-466-2400	414-466-3993
Minneapolis	351 Wilson Street, NE Minneapolis, MN 55413	Josh Nelson	612-331-3770	612-331-3549
Nashville/Memphis	221 Blanton Avenue, Nashville, TN 37210	Jamie Utley	615-248-2667	615-248-2676
New Orleans	102 Sampson Street, Houston, TX 77003	Cal Zenor	713-228-1524	713-228-1528
New York	2 Powers Lane, Brewster, NY 10509	John Partridge	914-235-6300	914-576-6483
Philadelphia	2 Powers Lane, Brewster, NY 10509	Greg Stephenson	800-524-3244	914-576-6483
Phoenix	3602 E. Southern Ave, Suite 5 Phoenix, AZ 85040	Patrick Styly	602-431-8024	602-431-8027
Pittsburgh	1360 Island Avenue, McKees Rocks, PA 15136	Bill Dugan	412-771-3010	412-771-9858
Portland	18808 142nd Ave NE, Suite 4A, Woodinville, WA 98072	Jim Swink	360-608-6845	206-762-5817
Rochester	36 Van Auker Blvd., Rochester, NY 14608	Mark Harper	800-524-3244 / 585-529-4188	914-576-6483 / 585-529-5319
Salt Lake City	3120 W. California Ave, Suite E, Salt Lake City, UT 84104	Don Manning	801-466-9428	801-466-3083
San Francisco	28970 Hopkins Street, Suite B+C, Hayward, CA 94545	John O'Brien/Craig Hering	510-293-1500	510-293-1505
Seattle	18808 142nd Ave NE, Suite 4A, Woodinville, WA 98072	Darin Arnold/Jim Swink	206-762-5812	206-762-5817

## INTERNATIONAL LOCATIONS

COUNTRY/REGION	ADDRESS	CONTACT	PHONE	FAX
Australia	Factory 3, 205 Abbotts Road, Dandenong, South Victoria 3175	Peter Pratis	+61 3 8787 5888	+61 3 8787 5899
Canada	6950 Edwards Blvd. Mississauga, Ontario L5T 2W2	Mark Russell	905-673-7295	905-673-6490
China	Metropolitan Business Centre, East Nandan Road, Lane 300, No. 9, Room 604 Xuhui District, Shanghai, China 200030	Jake Olsen	+86-21-3363-2880	+86-21-5080-5389
Europe	Westrak 208, 1771 SV Wieringerwerf, Netherlands	Colin Earl	+31 888 769 377	+31 227 594 759
Manitoba	1810 Dublin Avenue Man. Winnipeg, R3H 0H3	Distributor	204-633-0064	204-694-1261
New Zealand	PO Box 302 076 North Harbour Auckland	Clay Sesto	+64 9415 2425	+64 9415 2627
Quebec	721 Meloche Avenue, Dorval, Quebec H9P 2S5	Allan Hill	514-631-4216	514-631-2583

## LATIN &amp; CARIBBEAN DISTRIBUTION INQUIRIES

COUNTRY/REGION	ADDRESS	CONTACT	PHONE	FAX
Latin America		Allan Herbert	01150767477749	914-576-6483

## LATIN &amp; CARIBBEAN DISTRIBUTION

COUNTRY/REGION	ADDRESS	CONTACT	PHONE	FAX
Brazil	HARD, Rua Dr. Humberto Pinheiro Viera, 150 Lote B, 1 B Distrito Industrial, Joinville, Brazil		55-47-40097209	55-47-40097217
Colombia	Electrogeno, S.A., Carrera 52 #71c-38, Bogota, Colombia		(57) 1 6600 9436	
Costa Rica	Electro Mechanics Supply, La Uruca Contiguo Banco Ntrnl., De Costa Rica Condominio, Horizontal Bodega #9, San Jose, Costa Rica		(506) 2233-2595	
Dominican Republic	Calle Estancia Nueva #17 E Esquina Cul-De-Sac 9, San Geronimo, Santo Domingo	Rodfor Team	809-224-5615	809-472-8640
Ecuador	Acero Comercial Ecuatoriano S.A., Av. La Prensa N45-14 y Telégrafo 1 – Quito	info@acero.comercial.com	(593-2) 2454 333	(593-2) 2454 455
	Av. Juan Tanca Marengo Km. 1.7 – Guayaquil	info@acero.comercial.com	(593-4) 2683 060	(593-4) 2683 059
Guatemala	Tecnofijaciones, 6 Avenue 8-56 Zona 9, Zona 9, Guatemala	Oscar Lucas Penagos	502-233-4-3478	
Panama	Centro-Industrial, Via Cincuentenario, No. 7910, Ciudad Panama, Panama		(507) 302-8022	
Peru	Powers Peruana SAC, Av. Santa Catalina, 555 La Victoria, Lima 13, Peru (www.powersperuana.com)	Martin Vasquez	(011) 511 265 8500	(011) 511 330 0909
Venezuela	Calle Sucre/Qta. Maudora, #1721 Entre Cec Acosta Y San Ignacio Chacao, Caracas	Distributor	58 212 264 1313	58 212 263 0219
Trinidad - Tobago	Ft. Farfan, 3-5 Ibis Avenue, Ibis Acres, San Juan	Derek Cumming	(868) 674-7896	

Note: The information and data contained within this documentation was current as of April 2013. The information is for marketing purposes only and is subject to change and updates as needed. Powers Fasteners, Inc. reserves the right to change designs and specifications without notice or liability for such changes. Please contact Powers Fasteners for the most current and up to date available information or refer to our website at [www.powers.com](http://www.powers.com)

**Powers Fasteners** 2 Powers Lane, Brewster, NY 10509 P: (914) 235-6300 F:(914) 576-6483  
**Powers Fasteners Canada Ltd.** 6950 Edwards Boulevard Mississauga Ontario L5T-2W2 Canada  
P: (905) 673-7295 or 1-800-387-3480 F: (905) 673-6490

[www.powers.com](http://www.powers.com)  
Cat. No. 49053 4/13  
©2013 Powers Fasteners, Inc.

